

Heating Ventilation and Cooling Unit - Paragon HVAC Series Installation, Operation, and Maintenance Manual

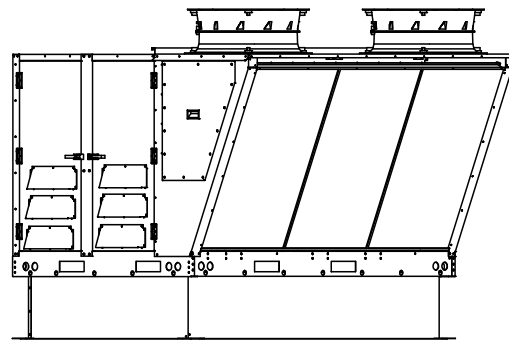
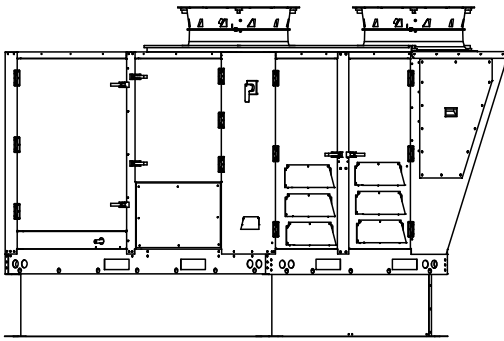

WARNING! FIRE OR EXPLOSION HAZARD

- Failure to follow safety warnings exactly could result in serious injury, death or property damage.
- Make sure to read and understand the installation, operation and service instructions in this manual.
- Improper installation, adjustment, alteration, service or maintenance can cause serious injury, death or property damage.
- Read the installation, operating and maintenance instructions thoroughly before installing or servicing this equipment. ALWAYS disconnect power and gas prior to working on unit.

FOR YOUR SAFETY

Do not store or use gasoline or other flammable vapors and liquids in the vicinity of this or any other appliance. Installation and service must be performed by a qualified installer, service agency or gas supplier.

WHAT TO DO IF YOU SMELL GAS:

- Do not try to light any appliance. Do not touch any electrical switch; do not use any phone in your building.
- Leave the building immediately. Immediately call your gas supplier from a phone remote from the building.
- Follow the gas supplier's instructions. If you cannot reach your gas supplier, call the fire department.

IMPORTANT

Some units may contain an energy recovery wheel. By virtue of their design, all energy recovery wheels allow a level of return/exhaust air and contaminants to be recirculated into the supply airstream. Accepting and operating this unit with or without the energy recovery wheel in operation increases the risk of airborne bacteria, virus and contaminant spread between the return/exhaust air, into the fresh airstream.

In accordance with ANSI/ASHRAE/ASHE Standard 170-2017, energy recovery wheel technology should not be used as a means of ventilation for certain Health Care Facilities. An ASHRAE Position Document on Infectious Aerosols, approved by ASHRAE Board of Directors, dated April 14, 2020, also recommends that energy recovery devices be bypassed for non-health care facility ventilation to help reduce the spread of virus.

Any reduction of outdoor air % or volume below what this unit was designed for elevates the risk of airborne bacteria, virus and contaminant recirculation back into the fresh airstream and the space.

Operating this unit with an exhaust level less than 50% of the supply level nullifies all return on investment statements and limits the amount of energy recovery.

This unit, including the energy recovery wheel, must be serviced and maintained as per the Installation and Operation Manual's recommended frequencies.

RECEIVING AND INSPECTION

Upon receiving unit, check for any interior and exterior damage, and if found, report it immediately to the carrier. Check that all accessory items are accounted for and free of damage. Turn the blower wheel by hand to verify free rotation and check the damper (if supplied) for free operation.

Table of Contents

WARRANTY	4	Sequence of Operation	95
Coastal Applications	4	Operation Summary - Gas Heating	95
Furnace Warranty	4	Modulating Gas System	95
CERTIFICATIONS	4	High Temperature Limit	95
Listings and Standards	4	Flame Safety Control (FSC)	96
INSTALLATION	5	Modulating Stage Sequence	96
Mechanical	5	MUA Board and High Fire Start	96
Inspection on Arrival	5	Re-Circulating Control Options	97
Unloading/Moving Unit	5	Powered Exhaust	97
Unit Location - Site Preparation	5	Outdoor Air Configuration	97
Rigging	8	Programmable Thermostat	97
Curb and Ductwork	9	Heating, Cooling, Defrost, and Reheat	98
Duct Hanger Dimensions	11	Economizer	101
Curb and Adapter	13	Psychrometric Chart	102
Supply Duct Pad Mount Clearances	14	Fixed Dry Bulb Economizer	102
Duct Static Pressure Control	15	Differential Dry Bulb Economizer	102
Building Static Pressure Control	15	Fixed Total Economizer	103
HMI and Remote Room Sensor Installation	16	Differential Total Economizer	103
Typical Submittal Drawing	17	Energy Recovery (Optional)	105
Furnace Condensation Drain	18	Purge and Pressurization	105
Cooling Coil Trap	19	Drive Motor	106
Heat Drain Kit	19	Frost Protection (Optional)	106
Gas	20	Variable Speed Frost Prevention	106
High Turndown Furnace	20	Energy Recovery Exhaust Hoods	106
Gas Train	21	Exhaust Fan	106
High Altitude and Gas Type Orifice Sizing	22	Slide-Out Wheel	106
LP Conversion Kit for RTU Series	24	Field Installation of Large ERVs	107
Pre-Conversion Unit Check-Out	25	SERVICE INFORMATION	109
Gas Conversion Instruction	26	Basic Service	109
Electrical	27	Monitoring the A/C System	110
Building to Unit Power Wiring Connection	28	Monitoring with HMI	110
Site Preparation – Controls	28	Monitoring with Gauge Set	110
Typical Wiring Schematic	29	Recovering Refrigerant from the System	111
Variable Frequency Drive (VFD)	30	Nitrogen Purging	111
Variable Frequency Drive (VFD) Installation	30	Pressure Testing	111
Input AC Power	30	Evacuating the System	112
VFD Output Power	31	Charging an Empty System	113
VFD Programming	31	Charging System Low on Refrigerant	114
ACTECH SMV VFD	32	Removing Manifold Gauge Set	114
Make-up Air (MUA) Board Connectors	33	TROUBLESHOOTING	115
ACB Connectors	44	System Troubleshooting Chart	115
Component Location	50	HMI Fault Codes	116
Optional Components	55	Condensing Fan Blink Codes	126
AC Interlock	55	Compressor Drive VFD Troubleshooting Chart	129
Burner Interlock	55	Compressor Troubleshooting Chart	131
Electric Cabinet Heater	55	Airflow Troubleshooting Chart	132
Communication Module	55	Furnace Troubleshooting Chart	133
Electric Heater Option	56	Superheat and Subcooling	134
Compressor Information	57	Component Check/Testing	136
VZH 044/035/028	57	MAINTENANCE	148
Compressor VZH 065	57	General Maintenance	148
Compressor VZH 088/117/170	58	Every 3 Months	148
Compressor Drive Information	59	Heating Season Maintenance	149
CDS803 Quick Menu Navigation	59	Cooling Season Maintenance	149
CDS803 Main Menu Navigation	59	Coil Cleaning Procedure	150
CDS803 Reset	59	Maintenance Quick Reference Chart	150
CDS302/303 Quick Menu navigation	60	Filters	151
CDS302/303 Main Menu	60	Resetting Unit	152
CDS302/303 Reset	60	Emergency Shutdown of Unit	152
Prolonged Shutdown of Unit	152	Start-Up and Maintenance Documentation	155
OPERATION	61		
Accessing Menu Configurations	61		
Remote (HMI) Control Panel	61		
HMI Notification Letters	61		
HMI Configuration Menu	62		
Communication	62		
Advanced Options	62		
Status	62		
About	62		
Scheduling	63		
Menu Descriptions	64		
UNIT OPERATION	92		
Start-Up Procedure	92		
Start-Up Procedure Heating	93		
Furnace Start-Up Summary	93		
High Fire Burner Adjustment	94		
Low-Fire Burner Adjustment	94		
Final Start-Up Procedure	94		

WARRANTY

This unit comes with a standard 5-year parts warranty from date of shipment to be free from defects in materials and workmanship, under normal use and service. An extended 10-year non-prorated parts warranty is available at no extra charge when units are remotely monitored and maintained through a Service Preventative Maintenance subscription (terms and conditions apply).

This warranty shall not apply if:

1. The equipment is not installed by a qualified installer per the MANUFACTURER'S installation instructions shipped with the product.
2. The equipment is not installed in accordance with Federal, State, and/or Local codes and regulations.
3. The equipment is misused or neglected, or not maintained per the MANUFACTURER'S maintenance instructions.
4. The equipment is not operated within its published capacity.
5. The invoice is not paid within the terms of the sales agreement.

The MANUFACTURER shall not be liable for incidental and consequential losses and damages potentially attributable to malfunctioning equipment. Should any part of the equipment prove to be defective in material or workmanship within the standard 5-year warranty period or the extended 10-year Preventative Maintenance subscription, upon examination by the MANUFACTURER, such part will be repaired or replaced by MANUFACTURER at no charge. The BUYER shall pay all labor costs incurred in connection with such repair or replacement. Equipment shall not be returned without MANUFACTURER'S prior authorization, and all returned equipment shall be shipped by the BUYER, freight prepaid to a destination determined by the MANUFACTURER.

NOTE: To receive warranty coverage, register this product by filling out the Start-up and Maintenance Document on page 155. Fax the form to 1-919-554-9374 or call 1-866-784-6900 for email information.

Coastal Applications

Units installed within 1-mile of salt-water coasts and waterways must be equipped with an E-Coated Outdoor Coil. Position the unit so the fresh air inlet and outdoor coil are protected from direct salt spray. Failure to protect the fresh air inlet and outdoor coil from direct salt spray will void the unit's warranty.

Furnace Warranty

Subject to all terms stated herein, the MANUFACTURER warrants to BUYER the stainless steel heat exchanger to be free from defects in material and workmanship under normal use and service for 25-years from the date of manufacture and warranty is limited to replacement of the heat exchanger only.

CERTIFICATIONS

Listings and Standards

This unit is ETL-listed to the following standards:

- Standard for Safety Heating and Cooling Equipment ANSI/UL 1995, CSA 22.2 no. 236
- American National Standard/CSA Standard for Gas Unit Heaters and Gas-Fired Duct Furnaces ANSI Z83.8-2016, CSA 2.6-2016

This unit has been tested in accordance to the following standards:

- ANSI/AHRI Standard 340/360 – 2007
- ANSI/ASHRAE Standard 37 – 2009

INSTALLATION

It is imperative that this unit is installed and operated with the designed airflow, gas, and electrical supply in accordance with this manual. If there are any questions about any items, please call the service department at **1-866-784-6900** for warranty and technical support issues.

IMPORTANT

For gas units, to prevent premature heat exchanger failure, do not locate any gas fired unit in areas where chlorinated, halogenated, or acid vapors are present in the atmosphere.

Mechanical

Inspection on Arrival

1. Inspect unit on delivery.
2. Photograph any visible damage.
3. Report any damage to the delivery carrier.
4. Request a written inspection report from the Claims Inspector to substantiate a claim.
5. File a claim with the delivery carrier.
6. Check unit's rating plate to verify proper electric and fuel type to meet job requirements.
7. Compare unit received with description of product ordered.

Unloading/Moving Unit

WARNING!

Verify the forklift's rated capacity can handle the equipment's weight. Operators are not to pick up and move loads that are unbalanced or too heavy.

- The forklift's forks must pass through the unit's forklift pockets and out through the other side.
- Blank off plates are installed at the factory to ensure the unit is lifted as its proper center of gravity.
- The unit must be moved slowly, approximately raised 6-8" off of the ground.

Unit Location - Site Preparation

- Do not locate any gas-fired equipment near corrosive, explosive vapors such as chlorinated or acid vapors.
- Unit should not be accessible to the public.
- **Do Not Allow Children Around the Unit Supervised/Unsupervised.**
- Avoid overhead power lines, or other utility access points to prevent accidental contact or damage.
- Provide clearance around the installation site to safely rig and lift the equipment into its final position onto adequate supports. Refer to the manufacturer's estimated weights.
- Consider general service and installation space when locating the unit.
- Locate the unit close to the space it will serve to reduce long and twisted duct runs.
- Do not allow the air intake to face prevailing winds. The airflow switch may trip in high winds.
- Situate the unit above ground or at roof level high enough to prevent precipitation from being drawn into its inlet.
- The inlet must also be located at least 10 feet away from any exhaust vents.
- The inlet must be in accordance with the applicable building code provisions for ventilation air.
- The unit must have adequate structural support, or the equipment or building could be damaged.
- Do not alter or otherwise restrict combustion or ventilation openings.

CLEARANCE TO COMBUSTIBLE MATERIALS

This equipment may be installed with clearances from the equipment to combustible material not less than 0 inches from the top, bottom, condenser side, front and back. The flue side must be installed 3 feet from combustible materials. Refer to Figure 1 for clearance details.

SERVICE CLEARANCE

For service accessibility and performance, this unit must have at least 3 feet of clearance on the intake and supply sides. Size 1, 2, and 3 units should have 3 feet of clearance on the condensing coil side, and size 4 units should have 4 feet. Clearance above condenser fans should be at least 10 feet. Refer to Figure 1 for clearance details.

Figure 1 - Unit Clearance

Size 1, 2, and 3 Unit Clearance

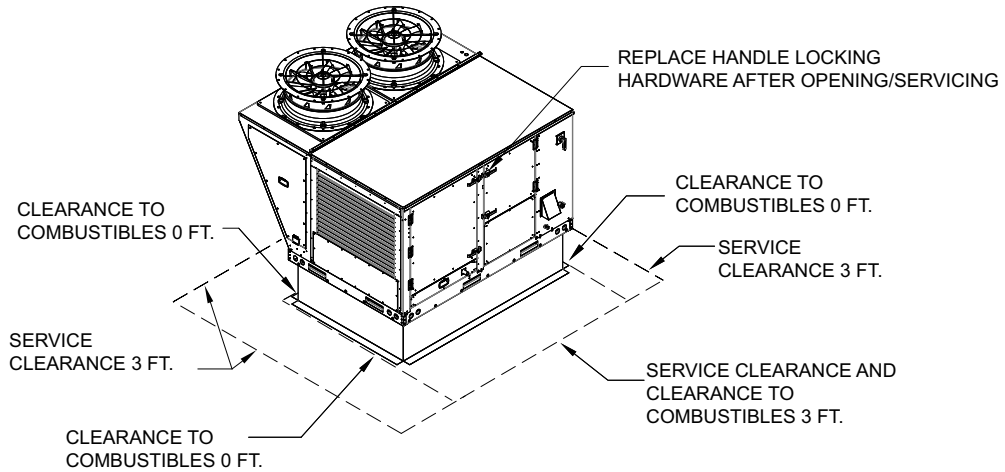

Size 4 Unit Clearance

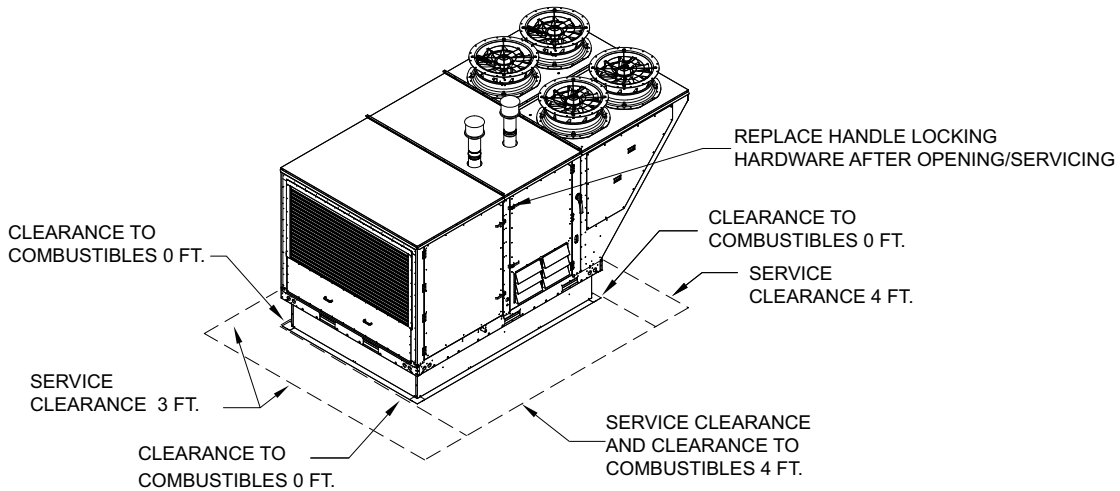

CLEARANCE TO COMBUSTIBLE MATERIALS

This equipment may be installed with clearances from the equipment to combustible material not less than 0 inches from the top, bottom, condenser side, front and back. The flue side must be installed 3 feet from combustible materials. Refer to Figure 2 for clearance details.

SERVICE CLEARANCE

For service accessibility and performance, this unit must have at least 3 feet of clearance on the intake and supply sides. Size 2 and 3 ERV units should have 3 feet of clearance on the condensing coil side, and size 4 ERV units should have 4 feet. Clearance above condenser fans should be at least 10 feet. Refer to Figure 2 for clearance details.

Figure 2 - ERV Unit Clearances

Size 2 and 3 Unit Clearance

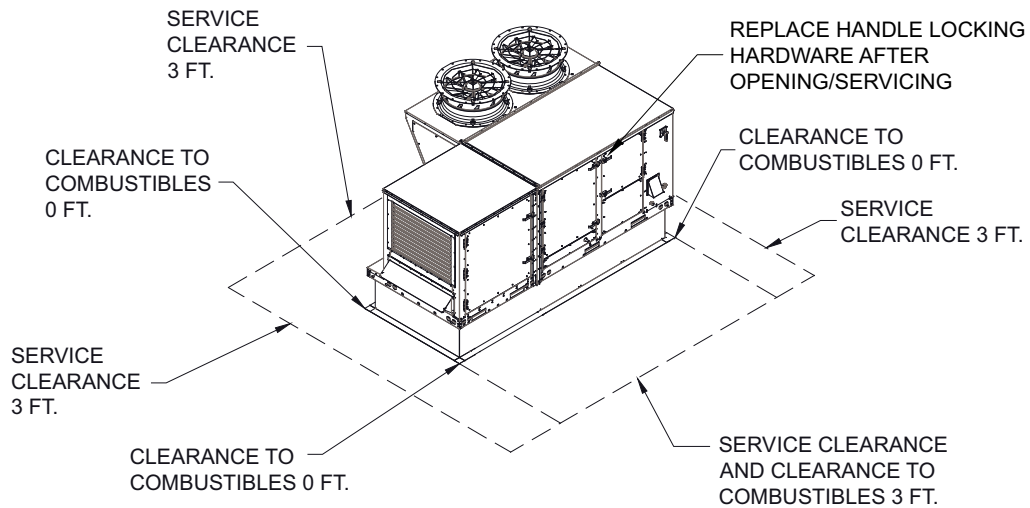

Size 4 Unit Clearance

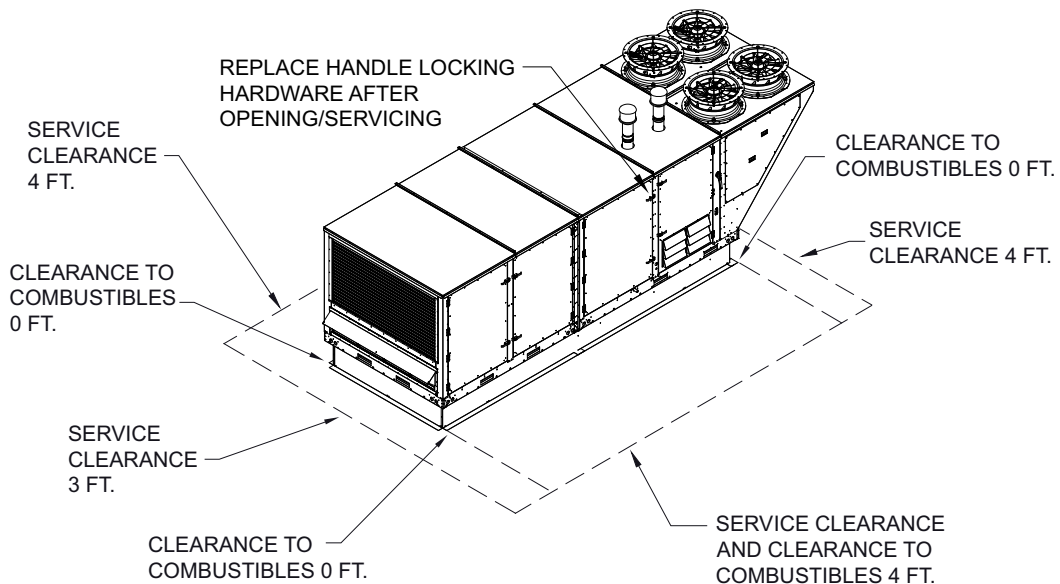

Rigging

WARNING!

Ensure that all the lifting equipment used is properly rated for the weight of the unit being lifted. Each of the cables (chains or slings), hooks, and shackles used to lift the unit must be capable of supporting the entire weight of the unit. Lifting cables (chains or slings) may not be of the same length. Adjust as necessary for even unit lift. Other lifting arrangements could cause equipment or property damage. Failure to follow instructions above or properly lift unit could result in unit dropping and possibly crushing operator/ technician which could result in death or serious injury.

Spreader bars must be used and should extend past the edges of the equipment to avoid damage to the casing. Not using spreader bars may cause damage to the unit casing. Refer to **Figure 3** for rigging details.

WARNING: DO NOT LIFT UNIT BY THE INTAKE LOUVER, OR DOOR OPENINGS – USE ALL LIFTING POINTS PROVIDED WITH A SPREADER BAR OR SLINGS UNDER THE UNIT – USE CARE NOT TO DAMAGE COILS, SWITCHES OR PROTRUDING SHEET METAL COMPONENTS.

- Units are supplied with multiple lifting points (eyes) on the bottom corners of the structural rails.
- Always use spreader bars to prevent damage to the unit casing.
- Test lift the unit approximately **2 feet** to verify proper center of gravity lift point. To avoid dropping unit, re-position lifting point if unit is not level. Failure to properly lift unit could result in unit dropping and possibly crushing operator/technician, which could result in death or serious injury and possible equipment or property damage.

Figure 3 - Rigging (Size 2 Unit Shown)

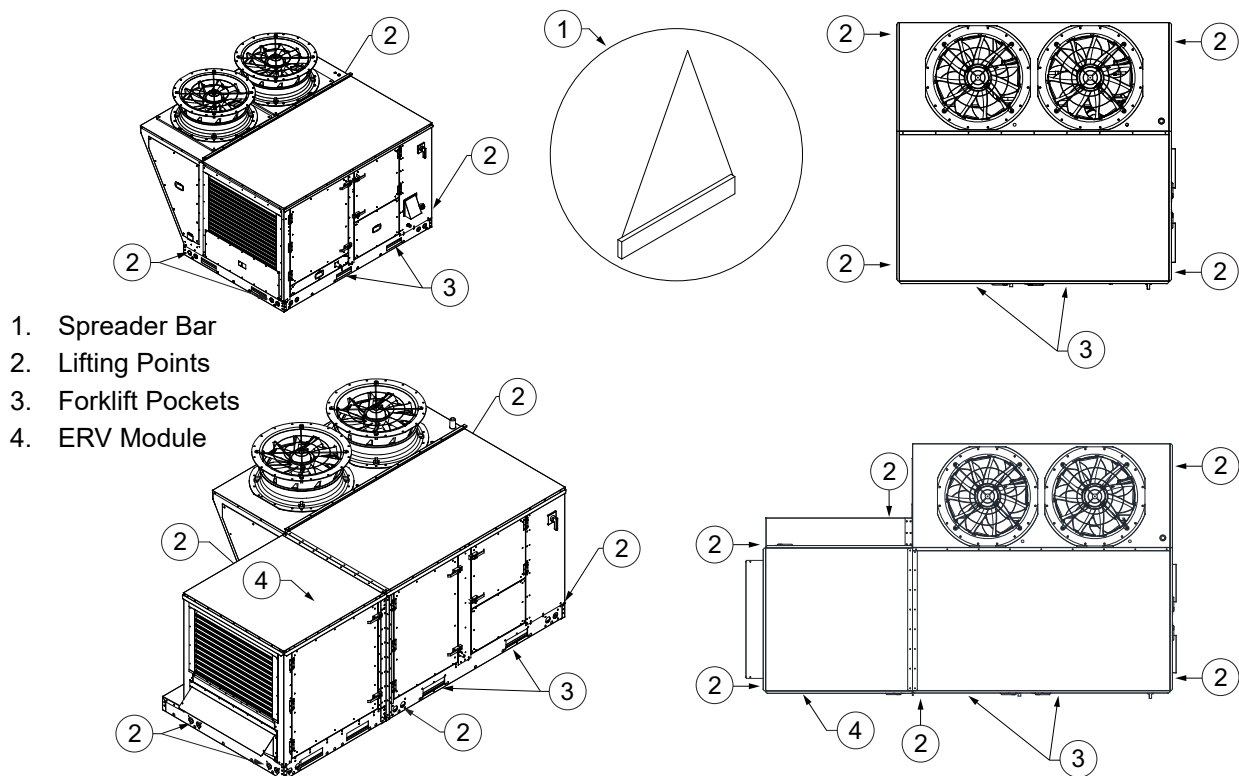

NOTE: For units without ERV, you must use at least four lifting point locations. For ERV units, at least 6 lifting points are required when raising the unit.

Curb and Ductwork

WARNING!!

Failure to properly size ductwork may cause system effects and reduce the performance of the equipment.

This unit was specified for a specific CFM and static pressure. The ductwork attached to this unit will significantly affect airflow performance. When using rectangular ductwork, elbows must be radius throat, radius back with turning vanes. Flexible ductwork and square throat/square back elbows should not be used. Any transitions and/or turns in the ductwork near the fan outlet will cause system effect. System effect will drastically increase the static pressure and reduce airflow. **Table 1** and **Table 2** detail the minimum fan outlet duct sizes required for optimal fan performance.

Table 1 - Recommended Supply Ductwork Sizes Up/Down Discharge

Unit Size	Up/Down Discharge Duct Size (Inches)	Down Return Duct Size (Inches)	Side Return Duct Size (Inches)	Straight Duct Length
1	21-1/4" x 19-1/4"	28" x 10"	29" x 10-1/2"	54"
2	20-1/4" x 30-1/4"	36" x 9"	36-1/4" x 11-1/4"	54"
3	39" x 21-1/2"	45-1/2" x 13-1/2"	45-1/2" x 10-3/4"	78"
4	39-3/4" x 39.5" (Up) 46-1/2" x 38-9/16" (Down)	74 x 12-1/4"	76-1/2" x 16-1/4"	96"

Table 2 - Recommended Supply Ductwork Sizes Side Discharge

Unit Size	Side Discharge Duct Size (Inches)	Down Return Duct Size (Inches)	Side Return Duct Size (Inches)	Straight Duct Length
1	20" x 19-1/4"	28" x 10"	29" x 10-1/2"	48"
2	20" x 14"	36" x 9"	36-1/4" x 11-1/4"	48"
3	25" x 14"	45-1/2" x 13-1/2"	45-1/2" x 10-3/4"	54"
4	42" x 21-1/4"	74" x 12-1/4"	76-1/2" x 16-1/4"	78"

- **Follow SMACNA guides and manufacturer's requirements for the remaining duct run.** Units designed for rooftop installation should be installed on a prefabricated or factory-built roof curb. Follow curb manufacturer's instructions for proper curb installation.
- **Do not use unit to support ductwork in any way. This may cause damage to the unit.**
- If installed in a geographical area where snow accumulates, the unit should be installed on a curb and/or rail elevated not less than **12-inches** above any surface. Verify installation meets local code height requirements.
- Verify duct connection and unit supply outlet are properly aligned and sealed. Use gasket between the curb and unit (**Figure 5 on page 10**).
- The curb and unit must be level, or the unit may leak or be damaged. If necessary, use shims to level the unit. Shims may be required depending upon curb installation and roofing material.
- Secure unit to curb with all available mounting points through vertical portion of the base assembly rails (**Figure 5**). Use lug screws, anchor bolts, or other suitable fasteners (not furnished).
- Check all fasteners are secure and tight.

Figure 4 - Curb

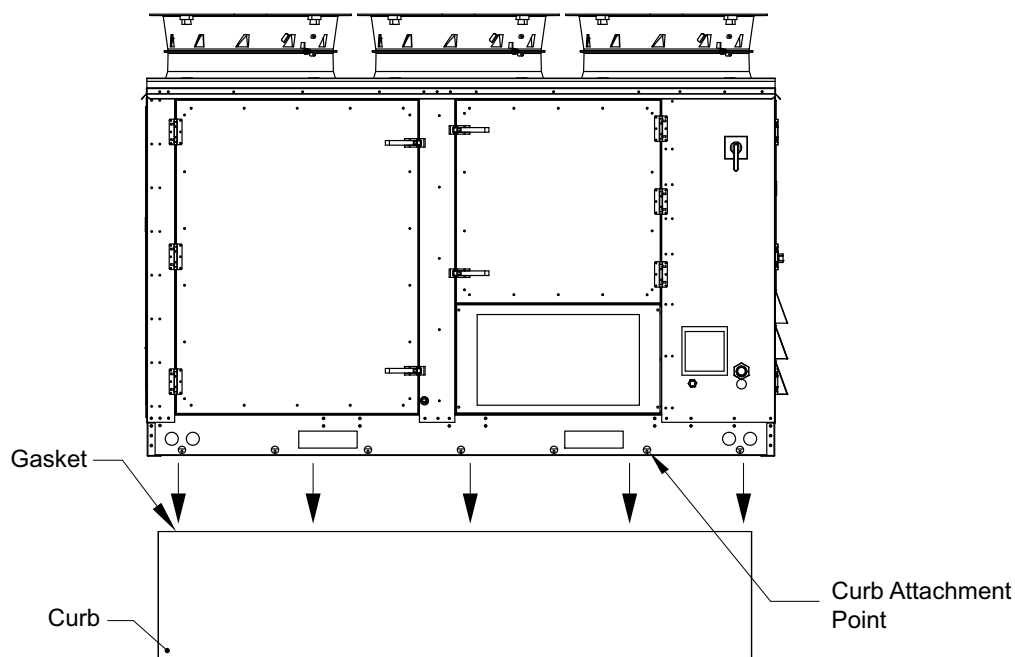

Side Return Duct/Access Panel Install, refer to **Figure 5** Detail A.

- Install gasket material around the upper and side edges.
- Install ductwork using self-tapping screws.
- Use caulk/sealant around the upper and side edges.
- Do not use caulk/sealant on the lower edge. Use only self-tapping screws to mount ductwork.

Side Discharge Duct Install, refer to **Figure 5** Detail B.

- Mount ductwork to the lip of the side discharge opening.
- Use self-tapping screws to secure ductwork.
- Verify the ductwork is clear for opening the top access panel door.

Figure 5 - Side Discharge, Side Return

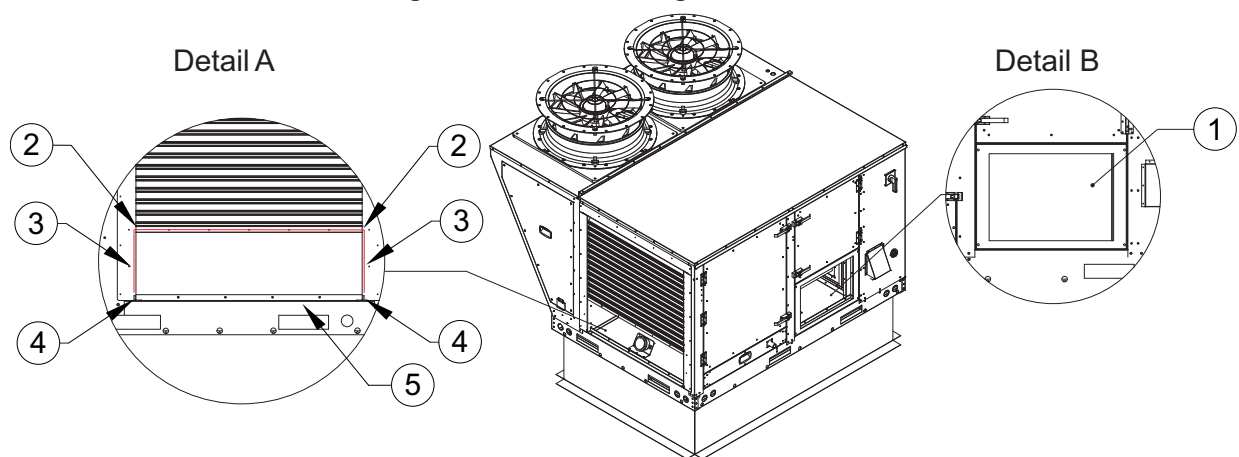

1. Discharge Outlet
2. Upper Edge - Use gasket/sealant for side return duct or access panel.
3. Side Edges - Use gasket/sealant for side return duct or access panel.
4. Damper Drain Holes - DO NOT COVER.
5. Lower Edge - DO NOT USE gasket/sealant.

Duct Hanger Dimensions

Figure 6 provides details for standard curbs, and Figure 7 provides details for ERV curbs. Refer to Table 3 and Table 4 on page 12 for Bill of Materials and curb dimensions.

Use 1/4"-20 x 5/8" Phillips pan head screws and nuts when assembling duct hangers, refer to Figure 8 on page 12.

Figure 6 - Standard Curb

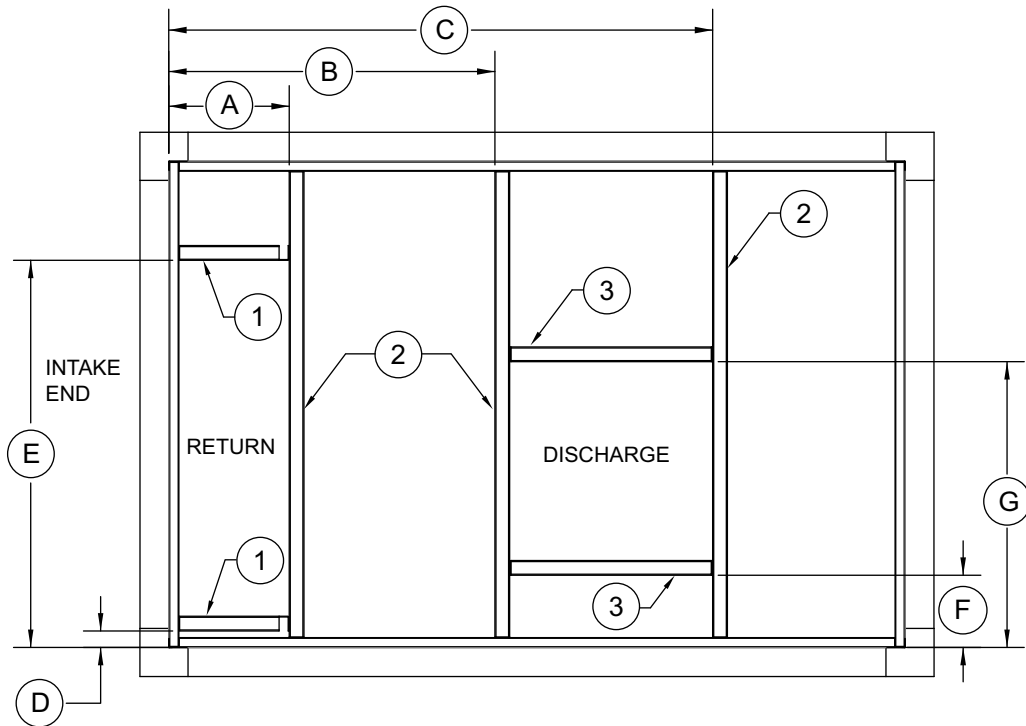

Figure 7 - ERV Curb

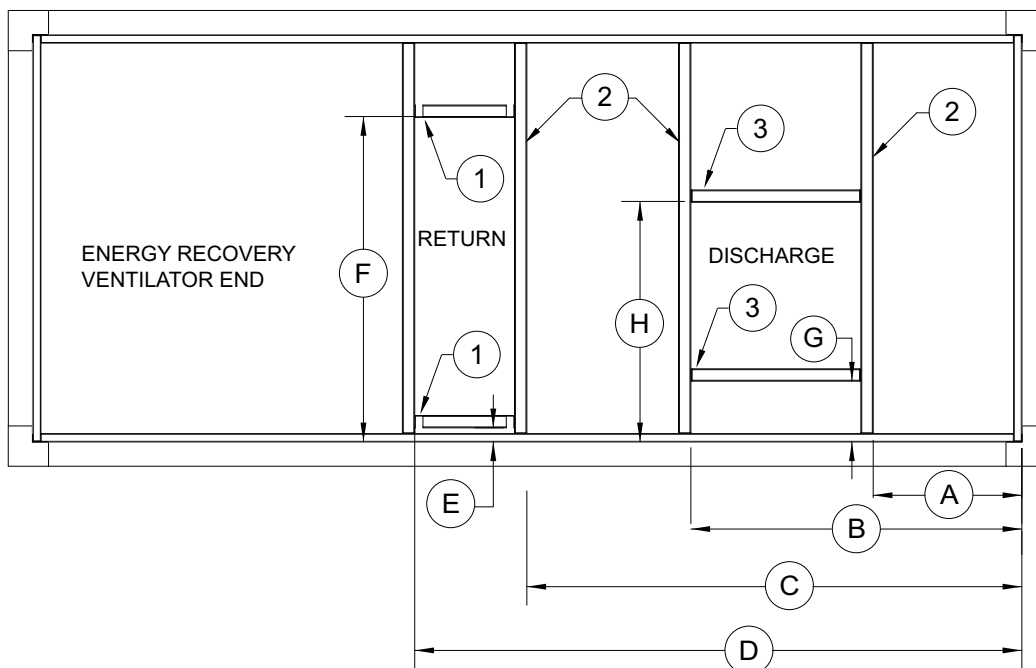

Table 3 - Duct Hanger Bill of Materials

Ref	Size 1	Size 2	Size 3	Size 4
1	RTU1DHR = Quantity x 1	RTU2DHR = Quantity x 2	RTU3DHR = Quantity x 1	N/A
2	RTU1DHL = Quantity x 3	RTU2DHL = Quantity x 3 NOTE: ERV Quantity x 4	RTU3DHL = Quantity x 3 NOTE: ERV Quantity x 4	RTU4DHL = Quantity x 3 NOTE: ERV Quantity x 4
3	RTU1DHD = Quantity x 2	RTU2DHD = Quantity x 2	RTU3DHD = Quantity x 2	RTU4DHD = Quantity x 2

Table 4 - Duct Hanger Curb Dimensions

Reference	Size 1	Size 2	Size 2 ERV	Size 3	Size 3 ERV	Size 4	Size 4 ERV
A	12-3/4"	12-1/4"	18"	16-5/8"	17-7/8"	15-1/2"	13-1/2"
B	36-1/4"	33-3/8"	40-1/4"	48-1/8"	41-3/8"	54-7/8"	54-5/8"
C	59-1/4"	55-1/2"	60-1/4"	71-5/8"	72"	96"	93-13/16"
D	N/A	1-3/4"	73-7/8"	N/A	90"	N/A	109-15/16"
E	31-1/4"	39-1/2"	1-3/4"	48-3/8"	N/A	N/A	N/A
F	5-1/4"	3-3/8"	39-1/2"	2-3/4"	40-3/8"	29-3/8"	N/A
G	27-3/4"	35-3/8"	7-3/8"	43-1/2"	2-5/8"	77-1/2"	29-3/8"
H	N/A	N/A	29-1/8"	N/A	43-1/2"	N/A	77-7/16"

Figure 8 - Duct Hanger Assembled

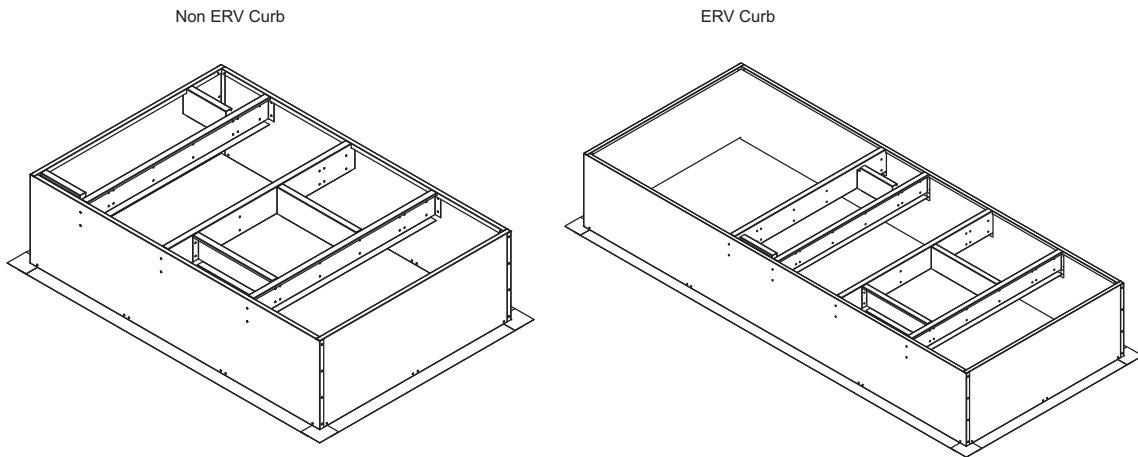

Figure 9 - Plenum Curb Installation

The plenum curbs (**Figure 9**) have a divider installed separating the discharge from the return.

When cutting the plenum curb, do not cut through the plenum divider.

Avoid cutting two adjacent sides at the same corner of the curb. This may weaken the curb structure.

Mark and cut through the plenum panels and insulation to fit up with the ductwork connections.

-Do NOT cut the side panels within 4" of each corner, top, bottom, or center.

-Do NOT cut the base panels within 2" of each side or center.

-Cutting outside of the allowable boxes shown above may weaken the curb structure.

Secure the duct to the plenum curb opening(s). Verify all seams have been fully sealed.

Tape all cut edges of the insulation to secure it to the curb.

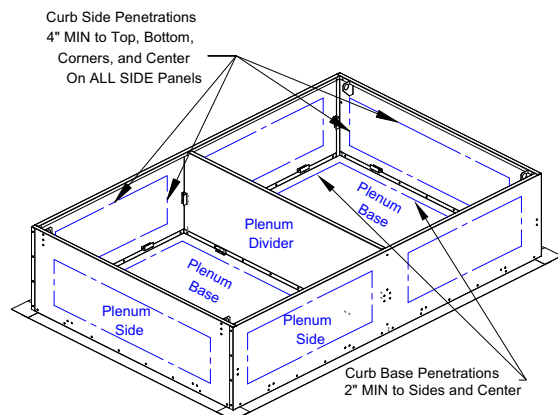

Curb and Adapter

Figure 10 provides details when mounting return and supply duct adapters to an RTU curb.

Figure 10 - Curb and Adapter Details

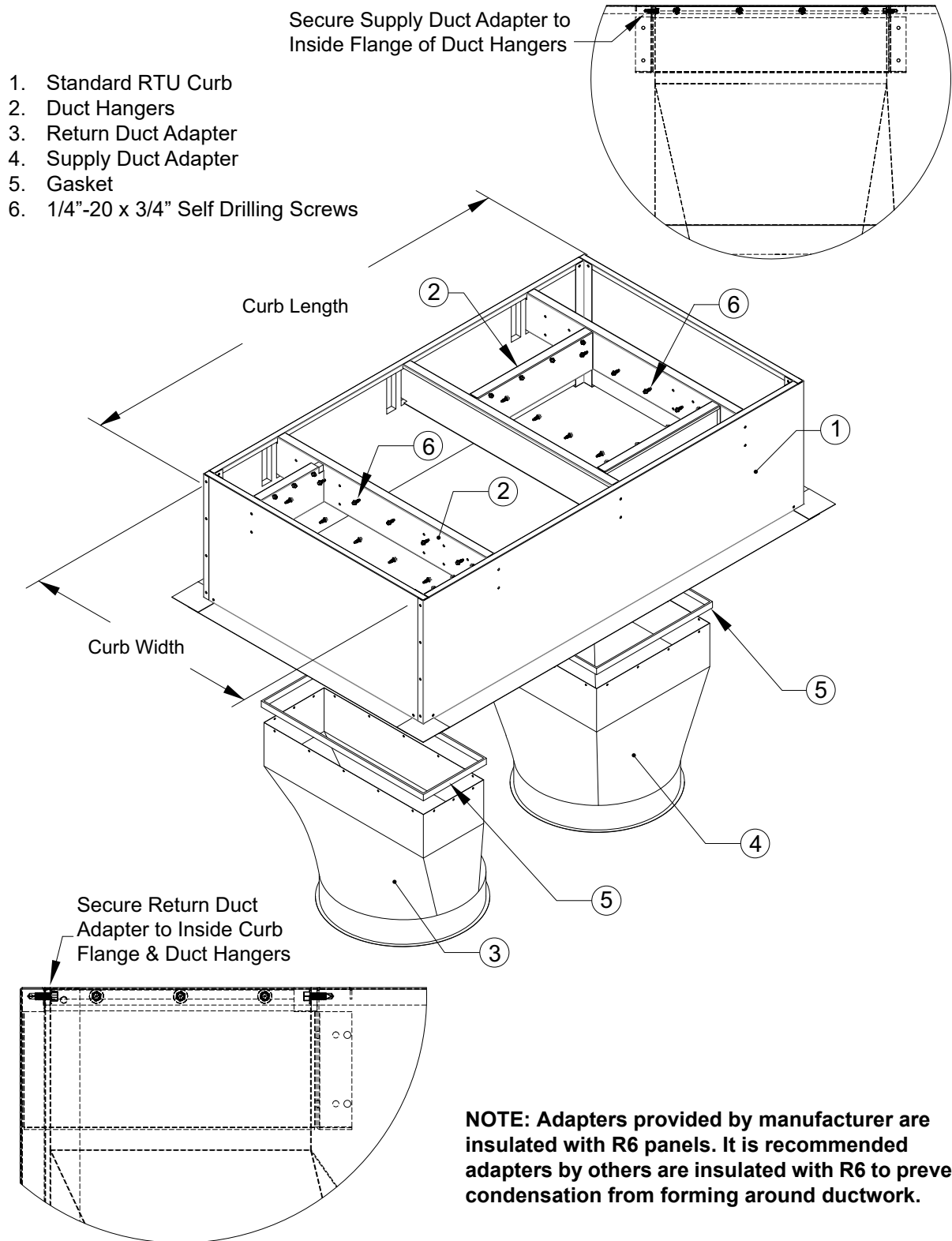

Supply Duct Pad Mount Clearances

When a unit will be pad mounted, refer to **Figure 11** for details on installation. Always verify the distance from the wall(s) to the unit. For the supply side of the unit, there must be adequate distance between the door and duct to service components.

The minimum unsupported distance for vertical ductwork is 20'. Anything over 20' requires a wall support bracket. 40' of vertical ductwork requires two wall support brackets, 60' would require three wall supports, etc.

A saddle support is required for horizontal duct runs. Center the saddle support to prevent stress on connections. Additional saddle supports are recommended every 15'.

Figure 11 - Supply Duct Installation Details

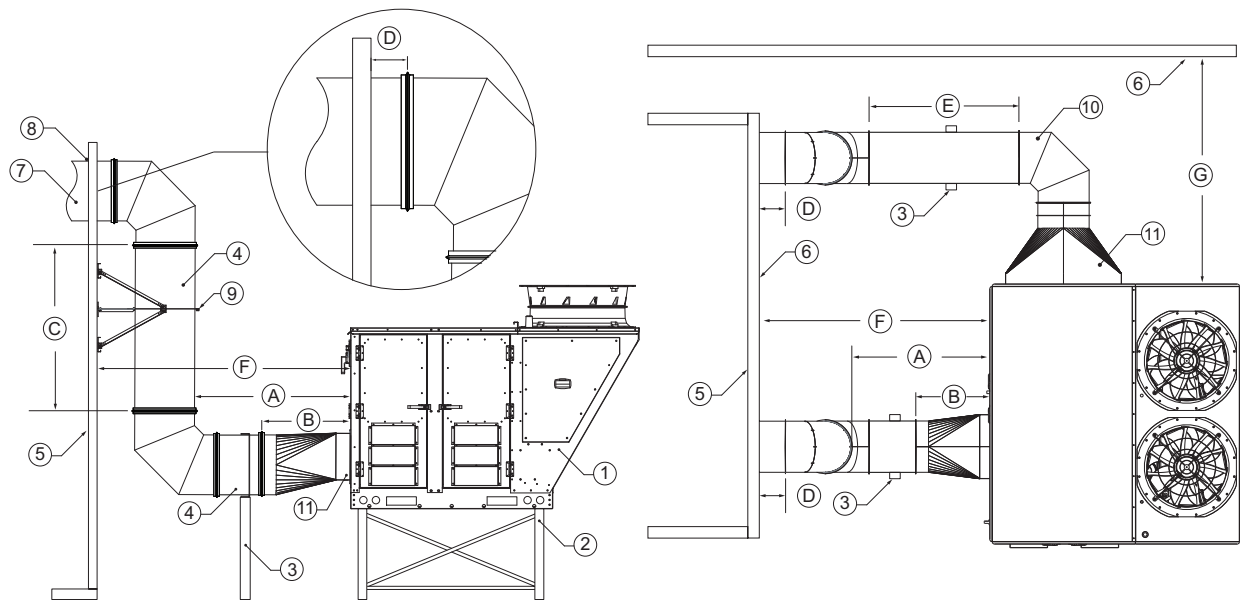

1. RTU
 2. RTU Stand
 3. Saddle Support
 4. Double Wall Supply Duct
 5. Interior Space
 6. Exterior Wall
 7. Adjustable Duct (Recommended)
 8. Closure Plate (Inside/Outside)
 9. Wall Support Bracket - Required for vertical ductwork lengths over 20'.
 10. Double Wall Return Duct
 11. Discharge Adapter - Verify the adapter is installed properly. The door above should be able to open without any interference.
- A. Door Opening Distance:
 - Size 1 = 24-1/2"
 - Size 2/3 = 25- 1/2"
 - Size 4 = 48-1/2"
 - B. Adapter Height = 24"
 - C. Minimum Unsupported Distance = 10'
 - D. Minimum Exterior Duct Penetration = 4"
 - E. Horizontal Support Recommended = Every 15' for Single Wall, every 8' for Double Wall
 - F. Minimum Distance Unit to Wall (Supply Side)
 - Size 1 = 62"
 - Size 2/3 = 70"
 - Size 4 = 98"
 - G. Minimum Distance Unit to Wall (Return Side)
 - Size 1 = 62"
 - Size 2/3 = 70"
 - Size 4 = 98"

Duct Static Pressure Control

Units equipped with an Electrically Controlled Motors (ECMs) or Variable Frequency Drives (VFDs) driven supply fan, the duct static pressure control option can be used to monitor duct pressure.

1. Locate where the pressure transducer is installed in the control cabinet.
2. Install the static pitot tube in a straight section of ductwork where the airflow is laminar and consistent.
3. Connect the high side tubing to the static pitot tube.
4. Route the tubing through the bottom of the unit to the high side port on the pressure transducer.
5. The low side pressure tubing will be connected to a brass port, measuring outdoor ambient pressure. The port is located by the unit's control cabinet doors. This will be connected from the factory.

Figure 12 - Duct Static Pressure Control

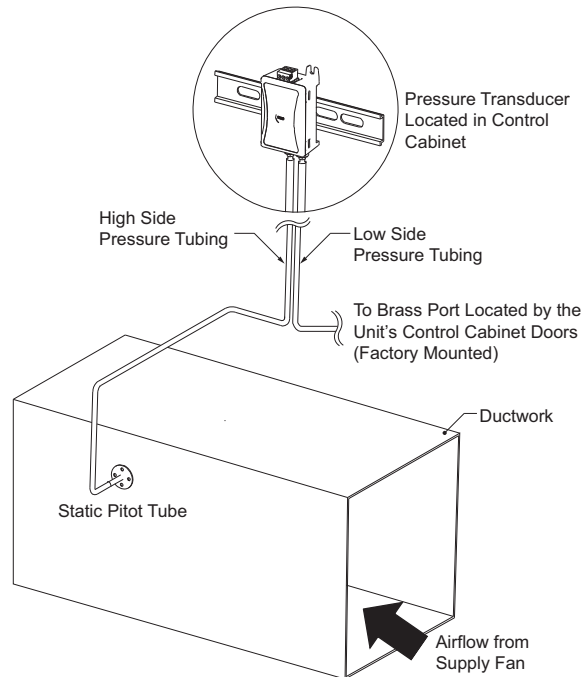

Building Static Pressure Control

Units equipped with an Electrically Controlled Motors (ECMs) or Variable Frequency Drives (VFDs) driven supply fan, the building static pressure control option can be used to monitor space pressure.

1. Locate where the pressure transducer is installed in the control cabinet.
2. Determine the space monitoring device:
 - Remote HMI, refer to “**HMI and Remote Room Sensor Installation**” on page 16
 - Room Pressure Pickup Sensor
3. Install the space monitoring device in the space.
4. Connect the high side tubing to the space monitoring device.
5. Route the tubing through the bottom of the unit to the high side port on the pressure transducer.
6. The low side pressure tubing will be connected to a brass port, measuring outdoor ambient pressure. The port is located by the unit's control cabinet doors. This will be connected from the factory.

Figure 13 - Building Static Pressure Control

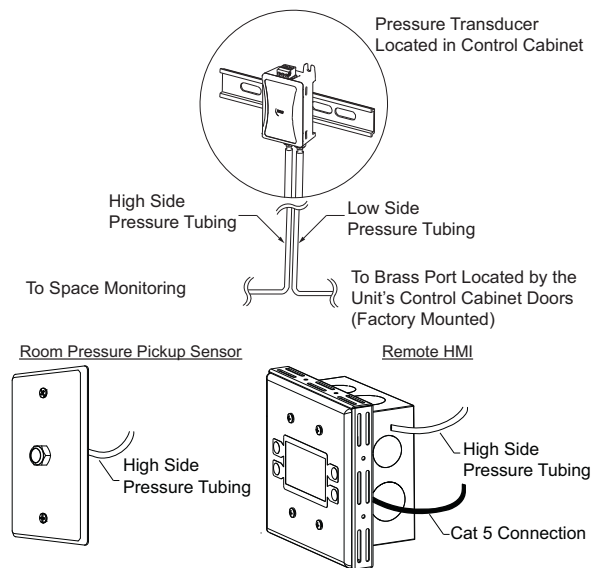

HMI and Remote Room Sensor Installation

The HMI (Human Machine Interface) is used to change settings, view operating information, and view fault history. Remote HMI faceplates (**Figure 14**), remote room sensors (**Figure 15**), and smart controls may be ordered and shipped separately. These components measure temperature and humidity and assist in controlling the unit. These components should be installed in a safe location, free of influence from external heat sources. Sensors must be installed in areas indicative of the average room temperature. Mounting the sensor(s) to interior walls will provide reliable measurements. Keep the sensor away from heat-producing appliances, direct sunlight, and away from operable windows/doors.

HMI and remote room sensors can be installed directly to industry-standard junction boxes, either surface mounted or recessed mounted. HMIs have a built-in temperature/relative humidity (RH) sensor, which is typically used to help control the automatic function of the unit.

The HMI can also be configured to control the unit from a remote location manually. They can be configured not to use the internal temperature/relative humidity sensor. In this configuration, the sensor in the HMI is ignored in automatic operation. Multiple HMIs can be connected to one unit for temperature and R/H averaging. All combination temperature/humidity HMIs will use a vented standoff. Mount the static pressure tube close to the HMI to obtain proper room conditions.

A max of 4 additional HMIs can be daisy-chained together. Place an End-of-Line (EOL) device in the last HMI connected.

Figure 14 - HMI with Standoff

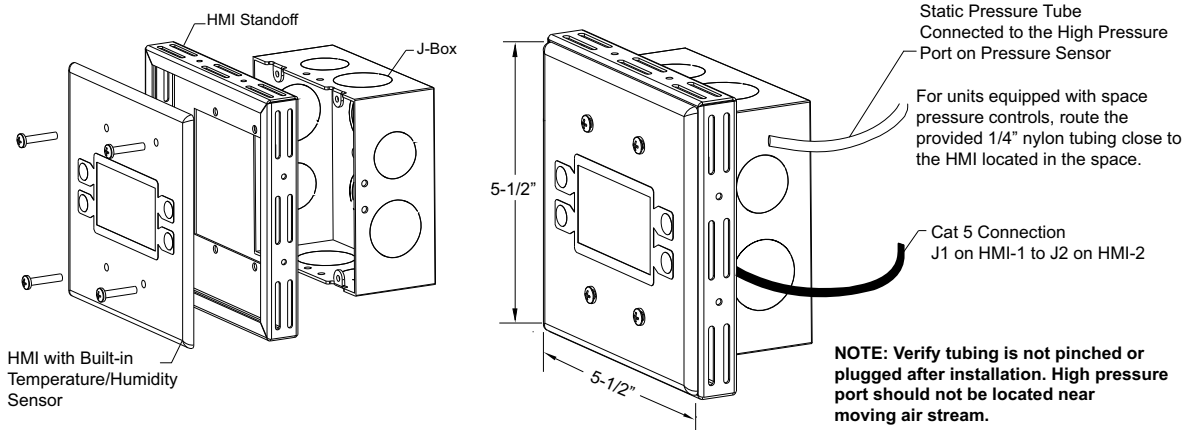
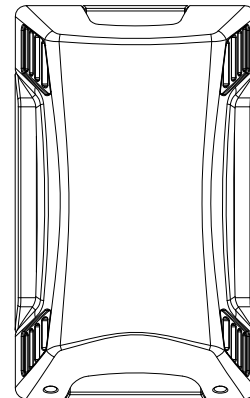

Figure 15 - Remote Temp/RH Sensor

The room temperature/humidity sensor is a 10K ohm thermistor. When connected to the 0-10V humidity sensor connection, the sensor provides constant room temperature and humidity (RH) readings to the controller. The sensor should be installed on a wall somewhere in the room, but not directly in the HVAC diffuser's path or close to heat-producing appliances so that the reading is not affected by heat.

Room sensors are not required for proper control operation, but still can be configured as remote sensors or averaging sensors.

Do not install the room sensor on the ceiling.



Typical Submittal Drawing

ROOFTOP UNIT DOWN DISCHARGE DOWN RETURN

RTU00DR
REV 47 05/15/19

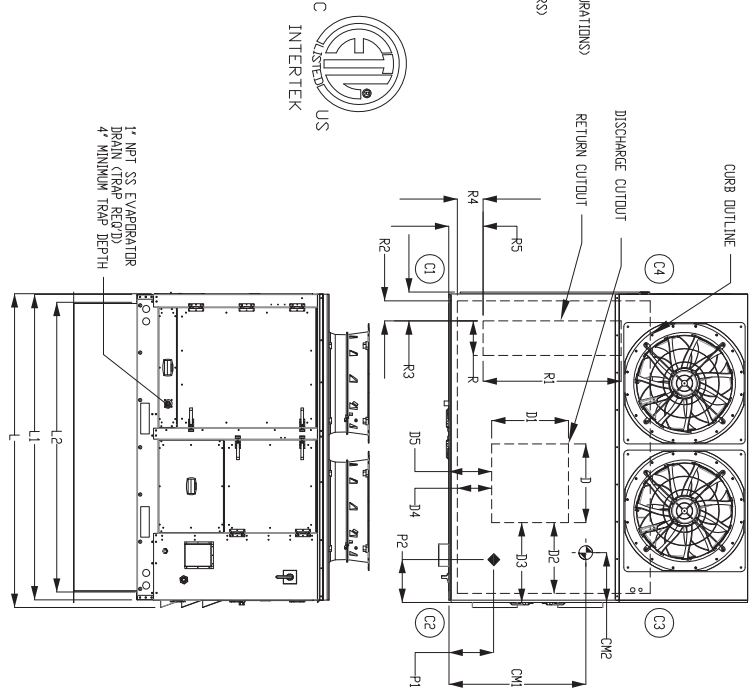
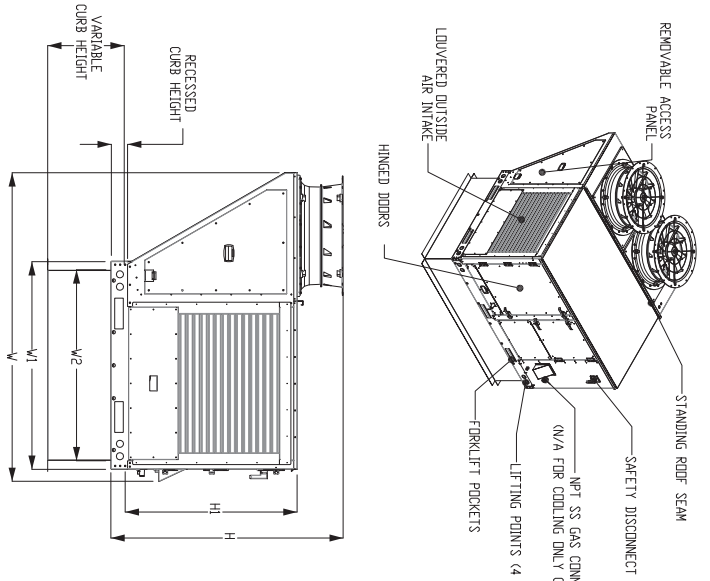

UNIT SIZE	NOMINAL TONNAGE	INTAKE FILTERS	SUPPLY FILTERS	FURNACE CAPACITY (MMBtu/h)	ELECTRIC CAPACITY (KW)	RTU INFORMATION*		CENTER OF MASS					CORNER WEIGHTS (LBS)					ENTERING POWER	
						APPROXIMATE WEIGHT (LBS)	RTU DIMENSIONS*	CM1	CM2	C1	C2	C3	C4	P1	P2				
2	8, 10	25 X 20 X 2 (2)	16 X 20 (8)	50 - 200	15 - 60	1650	37 1/4	32	36	441	537	369	303	5 1/4	7 1/4	5 1/2	7 1/2		
3	12.5, 15, 20	16 X 25 X 2 (4)	25 X 20 (8)	150 - 500	15 - 100	2500	37 1/4	44	472	572	798	658	5 1/2	7 1/2					

UNIT SIZE	UNIT LENGTH (L)	OUTSIDE BASE LENGTH (L1)	INSIDE BASE LENGTH (L2)	UNIT HEIGHT (H)	MOUNTED HEIGHT (H1)	UNIT WIDTH (W)	BASE WIDTH (W1)	INSIDE BASE WIDTH (W2)	RECESSED CURB HEIGHT	DISCHARGE DIMENSIONS					RETURN DIMENSIONS					CURB SIZE		
										D	D1	D2	D3	D4	D5	R	R1	R2	R3		R4	R5
2	81 3/4	79 3/4	75 3/4	60	45	80 3/4	54	49 3/4	3 1/2	20 1/2	20	19 3/4	22	9	12	9	36	3 1/4	5 1/2	3 1/4	6 1/2	75 x 49 1/2
3	99	96 3/4	91 3/4	68 1/4	52 3/4	89 3/4	65 1/4	60	4 1/4	21 1/2	39	20	23 1/4	4 1/4	8	13 1/2	45 1/2	3 1/2	6 1/4	2 1/2	6 1/4	91 x 59 1/2

*ALL DIMENSIONS IN INCHES UNLESS OTHERWISE SPECIFIED

- NOTES
- ROOF OPENING MUST BE 2" SMALLER THAN CURB DIMENSIONS
 - DO NOT DISTURB OUTSIDE AIR INLET, OUTSIDE AIR COIL, OR OUTSIDE AIR FAN
 - FILTER MOUNT ISOLATORS LOCATED 1" FROM END OF BASE IN QUANTITIES SHOWN. COIL CHANGE DEPENDING ON FILTER PRESSURE
 - ONLY APPLICABLE FOR INDIRECT HEAT OR ELECTRIC HEAT CONFIGURATIONS
 - SUBTRACT 100 LBS. FOR COOLING ONLY CONFIGURATIONS
 - 1" NPT SS GAS CONN. FOR 300-500 BHP FIREBOXES

Furnace Condensation Drain

In some applications, condensation can form in the flue collection box, especially when furnaces are located downstream of cooling coils or operate in a high-efficiency range. If condensation occurs in the flue collection box, there are fittings in the bottom of the flue collection box to drain condensation out of the box. The burner in the unit is provided with a condensation drain assembly located underneath this fitting for the condensation to collect. The drain will need to be connected to field piping to handle the condensation properly.

Consult your local code as to the proper drainage regulations of the condensation. A heated drain option is available to prevent the internal drain piping from freezing. If drains are field piped, ensure that the field piping is piped in a fashion to prevent the condensation from freezing. Do not plug the holes under any circumstance as it will cause the burners to overflow.

The standard efficiency furnace drain (**Figure 16**, detail A) is piped to the exterior of the unit via 5/16" silicone tubing. A 1/4" female NPT fitting is provided external to the unit to allow for field piping if required. If piping is added to the unit, freeze protection should be added to prevent damage to the field-installed piping.

The high-efficiency furnace drain (**Figure 16**, detail B) is fitted with a condensation float switch assembly, located in the bottom main cabinet, from the factory. A condensation drain must be field piped through the base of the unit using 3/4" PVC schedule 80 smooth fittings per the above requirements. A 2" deep trap must be field installed downstream of the unit to ensure adequate flow.

NOTE: Seal ALL base penetrations with appropriate filler (caulk or all-purpose putty) to prevent water from entering the space.

Figure 16 - Condensation Drain(s)

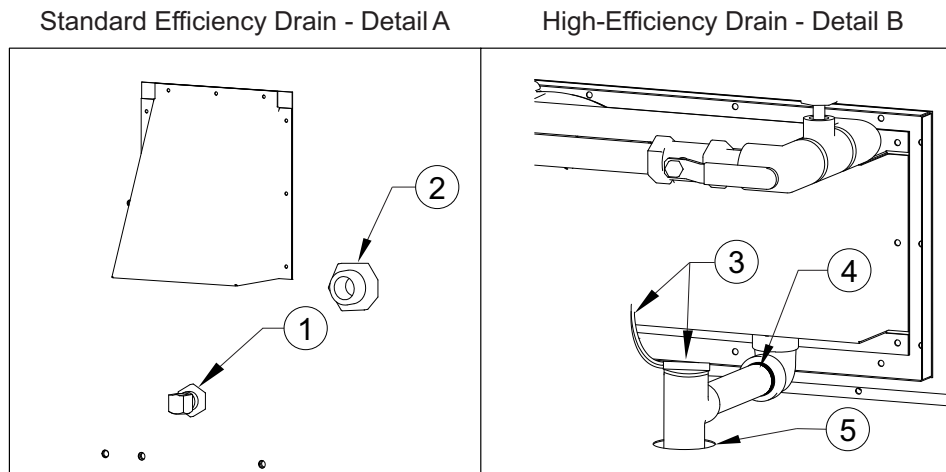

1. Standard efficiency drain connection. 1/4" NPT trap recommended.
2. 1/2", 3/4", or 1" NPT gas connection depending on furnace size.
3. Factory-installed high-efficiency condensation float switch assembly and wiring.
4. High-efficiency drain connection. 3/4" PVC schedule 80.
5. After drain pipe installation, seal base penetrations with an appropriate filler.

To test the factory-installed condensation float switch assembly:

- Turn the unit on, start the heating system. If the heating system does not run, verify the condensation float switch assembly wiring is correct.
- Remove the condensation float switch from the assembly. Lift the switching arm with a screwdriver. The heating system should shut off immediately. If not, check that the condensation float switch assembly's wiring connections are secure and tight. Re-check the float switch for proper operation.

Cooling Coil Trap

There is a field plumbing connection that is required for the DX/cooling coil. This connection is for the drain pan located under the DX/cooling coil. Also, it is recommended that all plumbing connections be sealed with Teflon tape or pipe dope.

Install Condensate Trap Assembly to 1" threaded drain pan connection. Use low-profile couplings and 1" PVC piping to connect on-site drainage to the Condensate Trap Assembly. **DO NOT USE UNIONS.** The Condensate Trap Assembly is important for two reasons. First, it will allow drainage to be piped to the most convenient area. Second, it will keep air from being drawn into the system, impeding drainage. The top lids of the Condensate Trap Assembly should be removable to allow for cleaning of the trap.

Figure 17 - Condensate Trap Assembly Details

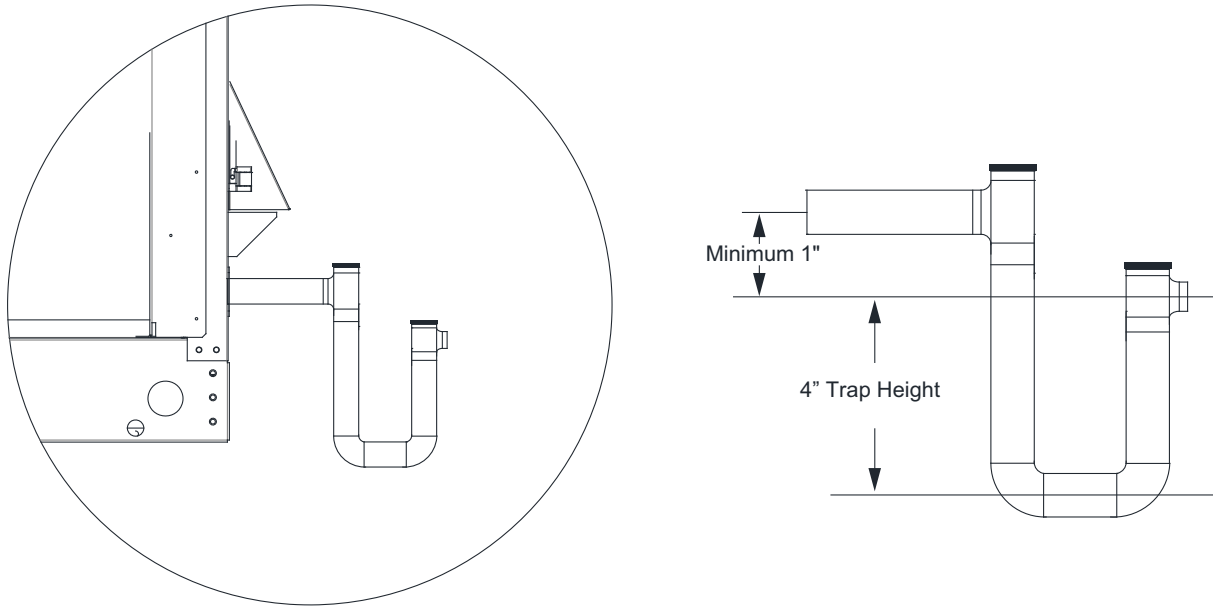

Heat Drain Kit

Units equipped with the Extreme Low Ambient option will include 50 feet of self-regulated heated cable. The heated cable will ship loose, and will need to be field-wired. The entire length of pipe exposed to ambient air should be wrapped in heated cable and insulated with foam pipe insulation, starting from the drain pan nipple and including the condensate drain assembly. The cable should run along the length of the pipe to be heated. If the cable is longer than the pipe, then the cable can be spiraled along the length of the pipe. The heat cable should be installed with zip ties. Wiring will be the responsibility of the installer.

Figure 18 - Heated Drain Kit Details

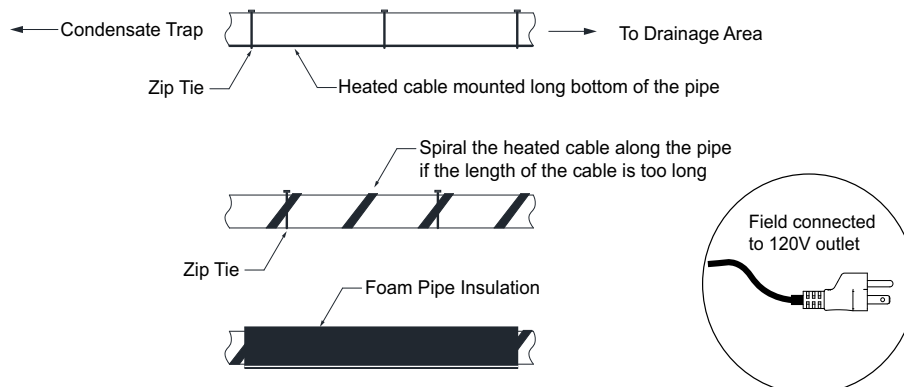

Gas

Installation of gas piping must conform with local building codes, or in the absence of local codes to the National Fuel Gas Code, ANSI Z223.1 (NFPA 54) – latest edition. In Canada, installation must be in accordance with CAN/CGA-B149.1 for natural gas units and CAN/CGA-B149.2 for propane units.

WARNING: Inlet gas pressure must not exceed pressure indicated on nameplate. See unit nameplate for proper gas supply pressure and gas type.

1. **Always disconnect power before working on or near a heater. Lock and tag the disconnect switch and/or breaker to prevent accidental power-up.**
2. Piping to the unit should conform to local and national requirements for type and volume of gas handled, and pressure drop allowed in the line. Refer to the Gas Engineer's Handbook for gas line capacities.
3. The incoming pipe near the heater should be sized to match the connection on the outside of the unit. Connection size is **1/2", 3/4", or 1" NPT** depending on furnace size. **See "Condensation Drain(s)" Detail A on page 13.** Verify unit inlet size to job-specific sheet. Avoid multiple taps in the gas supply, so the unit always has a steady supply of gas.
4. Install a ground joint union with brass seat and a manual shut-off valve external to the unit casing. Install shut-off valve adjacent to the unit for emergency shut-off and easy servicing of controls. **See Figure 19 on page 21.**
5. Provide a sediment trap, as shown in **Figure 19**, before each unit and where low spots in the pipeline cannot be avoided.
6. A minimum 1/8" NPT plugged tapping, accessible for test gauge connection, must be installed immediately upstream of the gas supply connection to the appliance.
7. Locate gas regulators away from the flue vent. Positioning the regulator underneath or nearby the flue may cause the regulator to freeze and prevent heating from properly operating.
8. Clean out the gas line to remove debris before making connections. Purge line to remove air before attempting to start unit. Purging air from gas lines should be performed as described in ANSI Z223.1-latest edition "National Fuel Gas Code," or in Canada as described in CAN/CGA-B149.
9. All field gas piping must be pressure/leak tested before unit operation. Use a non-corrosive bubble forming solution or equivalent for leak testing. The heater and its individual shut-off valve must be disconnected from the gas supply piping system during any pressure testing of that system at test pressures over 1/2 psi. The heater must be isolated from the gas supply piping system by closing its individual manual shutoff valve during any pressure testing of the gas supply piping system at test pressures equal to or less than 1/2 psi.
10. This unit requires a constant **7" water column (wc) minimum for natural gas supply (LP 11 in. wc minimum)** when the unit is operating at maximum gas flow. If the gas supply exceeds **14" wc**, it will damage the internal valve components. If the gas supply drops below **7" wc (LP 11 in. wc)**, the heater may not perform to specifications. Refer to **Table 5** for gas pressure type and pressure rating.

NOTICE

Refer to the heater rating plate for determining the minimum gas supply pressure for obtaining the maximum gas capacity for which this heater is specified.

High Turndown Furnace

The high turndown furnace will be divided into two separate furnace assemblies within the same cabinet. This results in a two stage heat source that can stage up and down to meet demand. Since the furnace is split unevenly, staging on the smallest will result in significantly higher turndown and greater control over building conditions. An additional Flame Safety Controller (FSC), safety valve, modulating valve, and high pressure switch (if equipped) will be installed. **See Figure 28 on page 53.**

Gas Train

A strainer must be installed to prevent debris from entering the gas train. Only use new piping. Properly ream and clean metal burrs. Proper care is needed to ensure that the gas flow is in the same direction as indicated on the strainer. Do not over-tighten pipe connections. Use pipe dope on male threads only. Install a drip leg in the gas line in accordance with the Authority Having Jurisdiction (AHJ) guidelines.

Figure 19 - Gas Connection Diagram

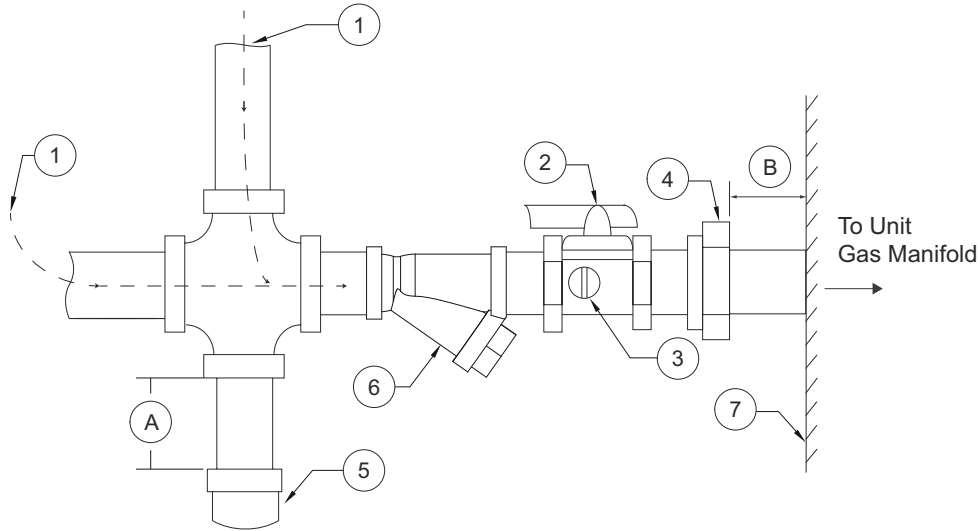

- | | |
|---|-------------------------|
| 1. Gas Supply Line Connection | 6. Strainer |
| 2. Manual Gas Shut-off Valve | 7. Unit |
| 3. Plugged 1/8" NPT Test Gauge Connection | A. Minimum Depth = 6" |
| 4. Ground Joint Union with Brass Seat | B. Maximum Length = 12" |
| 5. Sediment Trap | |

Proper clearance must be provided in order to service the strainer. A minimum of a 4" clearance distance must be provided at the base of the strainer.

Table 5 - Gas Train Details

Gas Pressure Type	Gas Pressure
Inlet Pressure - Natural Gas	7 - 14 Inches WC
Inlet Pressure - Propane (LP)	11 - 14 Inches WC
Maximum Manifold Pressure - Natural Gas	3.5 Inches WC Maximum
Maximum Manifold Pressure - Propane (LP)	10 Inches WC Maximum
Minimum Manifold Pressure - Natural Gas	0.15 Inches WC Maximum
Minimum Manifold Pressure - Propane (LP)	0.75 Inches WC Maximum
Strainer	Size
4417K64	3/4"
4417K65	1"
4417K66	1-1/4"
4417K67	1-1/2"
4417K68	2"
4417K69	2-1/2"
4417K71	3"

High Altitude and Gas Type Orifice Sizing

The burner orifices should be sized per **Table 6** and **Table 7**, depending on fuel type, furnace size, and altitude. Standard orifice sizes are for sea level. The unit should be ordered with the altitude specific orifices, or the parts should be ordered through the manufacturer (**Table 8 on page 23**). Refer to main gas valve documentation for instructions to convert gas valve spring from Natural to LP and vice versa.

NOTE: 50,000 - 100,000 BTU High-Efficiency Natural Gas furnaces use 2.3mm Drill Size at 0 - 3999 ft. Follow charts for all other altitudes.

Table 6 - Natural Gas High Altitude Charts

Size 3			Size 2 and 3		Size 1, 2, and 3			
High Altitude for 500,000 BTU			High Altitude for 400,000 BTU		High Altitude for 300,000 to 150,000 BTU			
Altitude (Feet)	Input Rate	Drill Size	Input Rate	Drill Size	Input Rate	Input Rate	Input Rate	Drill Size
0 - 1,999	500,000	#36	400,000	#41	300,000	200,000	150,000	#3/32
2,000 - 2,999	479,998	#37	384,000	#42	288,000	192,000	144,000	2.35mm
3,000 - 3,999	460,797	#38	368,640	2.35mm	276,480	184,320	138,240	2.3mm
4,000 - 4,999	442,668	#38	353,894	2.3mm	265,421	176,947	132,710	#43
5,000 - 5,999	424,668	#39	339,739	#43	254,804	169,869	127,402	2.25mm
6,000 - 6,999	407,680	#40	326,149	2.25mm	244,612	163,075	122,306	#44
7,000 - 7,999	391,372	#41	313,103	#44	234,827	156,552	117,414	2.15mm
8,000 - 8,999	375,716	#41	300,579	#45	225,434	150,290	112,717	#46
9,000 - 10,000	360,686	#42	288,556	#46	216,417	144,278	108,209	#47

Size 4					Size 4				
High Altitude for 800,000-600,000 BTU					High Altitude for 500,000 to 200,000 BTU				
Altitude (Feet)	Input Rate	Input Rate	Input Rate	Drill Size	Input Rate	Input Rate	Input Rate	Input Rate	Drill Size
0 - 1,999	800,000	700,000	600,000	3.4mm	500,000	400,000	300,000	200,000	3.3mm
2,000 - 2,999	768,000	672,000	576,000	#30	479,998	384,000	288,000	192,000	#30
3,000 - 3,999	737,280	645,120	552,960	#30	460,797	368,640	276,480	184,320	#31
4,000 - 4,999	707,789	619,315	530,482	#30	442,668	353,894	265,421	176,947	#31
5,000 - 5,999	679,477	594,543	509,608	#30	424,668	339,739	254,804	169,869	#31
6,000 - 6,999	652,298	570,761	489,224	#30	407,680	326,149	244,612	163,075	#31
7,000 - 7,999	626,206	547,930	469,654	#31	391,372	313,103	234,827	156,552	#32
8,000 - 8,999	601,158	526,013	450,868	#31	375,716	300,579	225,434	150,290	#32
9,000 - 10,000	577,112	504,973	432,834	#32	360,686	288,556	216,417	144,278	#33

Table 7 - LP Gas High Altitude Conversion

Size 3			Size 2 and 3		Size 1, 2, and 3			
High Altitude for 500,000 BTU			High Altitude for 400,000 BTU		High Altitude for 300,000 to 150,000 BTU			
Altitude (Feet)	Input Rate	Drill Size	Input Rate	Drill Size	Input Rate	Input Rate	Input Rate	Drill Size
0 - 1,999	500,000	#51	400,000	1.45mm	300,000	200,000	150,000	#54
2,000 - 2,999	479,998	#51	384,000	#54	288,000	192,000	144,000	#54
3,000 - 3,999	460,797	#52	368,640	#54	276,480	184,320	138,240	#55
4,000 - 4,999	442,668	#52	353,894	#54	265,421	176,947	132,710	#55
5,000 - 5,999	424,668	#52	339,739	#54	254,804	169,869	127,402	#55
6,000 - 6,999	407,680	#52	326,149	#55	244,612	163,075	122,306	#55
7,000 - 7,999	391,372	#53	313,103	#55	234,827	156,552	117,414	#56
8,000 - 8,999	375,716	#53	300,579	#55	225,434	150,290	112,717	#56
9,000 - 10,000	360,686	#53	288,556	#56	216,417	144,278	108,209	#57

Size 4					Size 4				
High Altitude for 600,000-800,000 BTU					High Altitude for 500,000 to 200,000 BTU				
Altitude (Feet)	Input Rate	Input Rate	Input Rate	Drill Size	Input Rate	Input Rate	Input Rate	Input Rate	Drill Size
0 - 1,999	800,000	700,000	600,000	#45	500,000	400,000	300,000	200,000	#45
2,000 - 2,999	768,000	672,000	576,000	#46	479,998	384,000	288,000	192,000	#46
3,000 - 3,999	737,280	645,120	552,960	#47	460,797	368,640	276,480	184,320	#47
4,000 - 4,999	707,789	619,315	530,482	#47	442,668	353,894	265,421	176,947	#47
5,000 - 5,999	679,477	594,543	509,608	#47	424,668	339,739	254,804	169,869	#47
6,000 - 6,999	652,298	570,761	489,224	#48	407,680	326,149	244,612	163,075	#48
7,000 - 7,999	626,206	547,930	469,654	#48	391,372	313,103	234,827	156,552	#48
8,000 - 8,999	601,158	526,013	450,868	#49	375,716	300,579	225,434	150,290	#49
9,000 - 10,000	577,112	504,973	432,834	#49	360,686	288,556	216,417	144,278	#49

Table 8 - Orifice Part Numbers and Quantity Charts

Orifice Part Numbers			Orifice Quantity per Furnace						
Size	Part #	AX #	Size	Part #	AX #	Size 1, 2, and 3	Qty	Size 4	Qty
#30	BG100-30	A0029277	#49	BG100-49	A0029283	50,000 BTU	2	N/A	-
#31	BG100-31	A0029278	#50	BG100-50	A0029284	75,000 BTU	3	N/A	-
#32	BG100-32	A0029279	#53	BG100-53	A0030724	100,000 BTU	4	N/A	-
#33	BG100-33	A0029280	#54	BG100-54	A0023048	125,000 BTU	5	N/A	-
#35	BG100-35	A0029281	#55	BG100-55	A0023049	150,000 BTU	6	N/A	-
#36	BG100-36	A0030719	#56	BG100-56	A0023057	200,000 BTU	8	200,000 BTU	4
#37	BG100-37	A0030721	#57	BG100-57	A0028803	300,000 BTU	12	300,000 BTU	6
#38	BG100-38	A0030722	1/16"	BG100-116	A0030725	400,000 BTU	15	400,000 BTU	8
#40	BG100-40	A0030723	1.45mm	BG101-16	A0023052	500,000 BTU	15	500,000 BTU	10
#41	BG100-41	A0023045	2.15mm	BG101-21	A0023055	N/A	-	600,000 BTU	11
#42	BG100-42	A0023050	2.25mm	BG101-20	A0023054	N/A	-	700,000	13
#43	BG100-43	A0023047	2.3mm	BG101-05	A0023051	N/A	-	800,000	15
#44	BG100-44	A0023046	2.35mm	BG101-19	A0023053				
#45	BG100-45	A0028800	3.3mm	BG101-08	A0029285				
#46	BG100-46	A0028801	3.4mm	BG101-09	A0030726				
#47	BG100-47	A0028802	#3/32	BG101-3/32	A0023044				
#48	BG100-48	A0029282							

LP Conversion Kit for RTU Series

LP/Natural Gas conversion kits are used to convert from one gas type to another in the field. This kit is used on all RTUs, and the part numbers in **Table 9** should be used on furnace sizes listed.

Kits contain:

- Main Safety Gas Valve Regulator Spring
- Furnace orifices marked with orifice size

This unit is configured for the gas type listed on the nameplate. To convert gas types, you must use the following parts listed in **Table 9**. The size-specific parts include the orifice conversion parts and the combination gas valve spring(s). These parts are available by contacting the **Parts & Service Department at 1 (866) 784-6900**. All field gas piping must be pressure/leak tested before unit operation. Use a noncorrosive bubble forming solution or equivalent for leak testing. The equipment and its individual shut-off valve must be disconnected from the gas supply piping system during any pressure testing of that system at test pressures in excess of 1/2 psi. The equipment must be isolated from the gas supply piping system by closing its individual manual shutoff valve during any pressure testing of the gas supply piping system at test pressures equal to or less than 1/2 psi. This must be performed on an annual basis.

Table 9 - Gas Conversion Kit Part Numbers

Size 1 Units						
Furnace Size	50 MBH	75 MBH	100 MBH	125 MBH	150 MBH	200 MBH
Natural Gas	NAT-HMG50	NAT-HMG75	NAT-HMG100	NAT-HMG125	NAT-HMG150	NAT-HMG200
LP Gas	LP-HMG50	LP-HMG75	LP-HMG100	LP-HMG125	LP-HMG150	LP-HMG200
Modulating Valve	E50-1/2"					

Size 2 and 3 Units									
Furnace Size	50 MBH	100 MBH	150 MBH	200 MBH	250 MBH	300 MBH	400 MBH	500 MBH	
Natural Gas	NAT-HMG50	NAT-HMG100	NAT-HMG150	NAT-HMG200	NAT-HMG250	NAT-HMG300	NAT-HMG400	NAT-HMG500	
LP Gas	LP-HMG50	LP-HMG100	LP-HMG150	LP-HMG200	LP-HMG250	LP-HMG300	LP-HMG400	LP-HMG500	
Modulating Valve	E50-3/4"							E60-1"	

Size 4 Units								
Furnace Size	200 MBH	300 MBH	400 MBH	500 MBH	600 MBH	700 MBH	800MBH	
Natural Gas	NAT-HMA200	NAT-HMA300	NAT-HMA400	NAT-HMA500	NAT-HMA600	NAT-HMA700	NAT-HMA800	
LP Gas	LP-HMA200	LP-HMA300	LP-HMA400	LP-HMA500	LP-HMA600	LP-HMA700	LP-HMA800	
Modulating Valve	E50-3/4"				E60-1"			

Pre-Conversion Unit Check-Out

The following procedure is intended as a guide to aid in determining that the appliance is properly installed and is in a safe condition for continuing use. It should be recognized that generalized test procedures cannot anticipate all situations. Accordingly, in some cases, deviation from this procedure may be necessary to determine safe operation of the equipment:

- This procedure should be performed before any attempt at modification of the appliance or the installation.
- If it is determined there is a condition that could result in unsafe operation, the appliance should be shut off, and the owner advised of the unsafe condition.

Follow these steps when making a safety inspection:

1. Conduct a gas leakage test of the appliance piping and control system downstream of the shut-off valve in the supply line to the appliance.
2. Visually inspect the venting system for proper size and horizontal pitch and determine there is no blockage or restrictions, leakage, corrosion, or other deficiencies that could cause an unsafe condition.
3. Shut off all gas to the appliance and shut off any other fuel-burning appliance within the same room. Use the shut-off valve in the supply line to each appliance.
4. Inspect burners and crossovers for blockage and corrosion.
5. Inspect heat exchangers for cracks, openings, or excessive corrosion.
6. Insofar as is practical, close all windows and all doors between the space where the appliance is located and other spaces of the building. Turn on any exhaust fans so that they will operate at maximum speed. If it is believed sufficient combustion air is not available, refer to the section covering air for combustion, venting, and ventilation of *Natural Gas and Propane Installation Code, CSA B149.1*, or *National Fuel Gas Code, ANSI Z223.1/NFPA 54*, for guidance.
7. Place the appliance in operation following the lighting instructions. Adjust thermostat so the appliance will operate continuously. Other fuel-burning appliances shall be placed in operation.
8. Determine that the main burner ignition is satisfactory by interrupting and re-establishing the electrical supply to the appliance in any convenient manner.
 - Visually determine that main burner gas is burning properly.
 - If the appliance is equipped with high- and low-flame control or flame modulation, check the main burner for proper operation at low flame.
9. Test for spillage at the draft hood relief opening after 5 minutes of main burner operation. Use a draft gauge, the flame of a match, or candle.
10. Return doors, windows, exhaust fans, and all other fuel-burning appliances to their previous conditions of use.
11. Check both limit control and fan control for proper operation. Limit control operation can be checked by temporarily disconnecting the electrical supply to the supply motor and determining that the limit control acts to shut off the main burner gas.

Gas Conversion Instruction

Warning

This conversion kit shall be installed by a qualified service agency in accordance with the manufacturer's instructions and all applicable codes and requirements of the authority having jurisdiction. If the information in these instructions is not followed exactly, a fire, explosion or production of carbon monoxide may result causing property damage, personal injury or loss of life. The qualified service agency performing this work assumes the responsibility for the proper conversion of the appliance with this kit.

Follow the below steps when converting gas types, refer to **Figure 20** for details:

1. Before proceeding with the conversion, shut off all gas supply to the unit at the manual shut-off valve.
2. Disconnect or shut off all electrical power to the unit.
3. Turn the thermostat to the lowest temperature setting.
4. Remove screws holding manifold pipe assembly to burner assembly.
5. Loosen and remove natural gas orifices, remove from manifold.
6. Install propane gas orifices provided with kit. Verify orifice sizes are correct.
7. Open Gas Valve Regulator conversion kit and follow instructions provided for conversion of gas valve regulator. **Make sure to apply the label provided in the kit indicating that the valve has been converted. The spring tension is different for LP and Natural Gas. This is the main component difference.**
8. Secure manifold assembly to burner assembly. Check that all orifices are aligned with the opening on each burner.
9. Turn on gas supply at manual shut-off valve.
10. Leak check union fitting and connection at gas valve using a soap solution.
11. Turn power to the unit "On."
12. Initiate a heating cycle. Check inlet and manifold gas pressures.
13. A label is included in this kit to attach to the manifold indicating this assembly has been converted to LP gas.
14. Attach label to manifold where it is readily visible when this assembly is accessed for service.
15. Verify proper sequence of operation for appliance after conversion is completed.
16. Verify proper gas inlet supply pressure and information on maximum and minimum supply pressures.

Figure 20 - On/Off Gas Valve

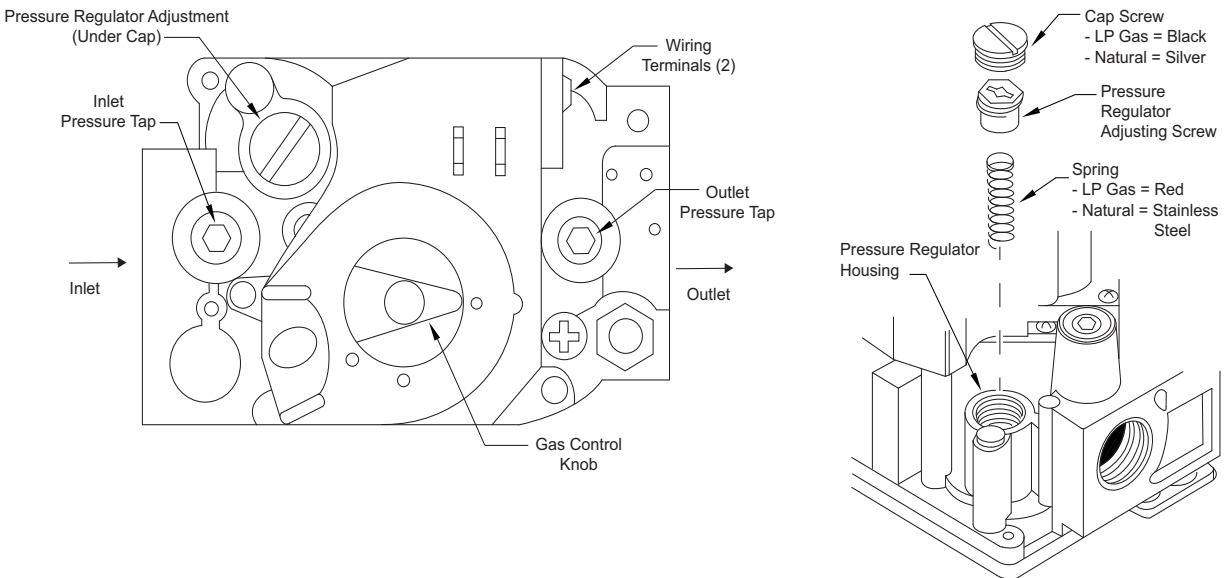

Electrical

WARNING!!

Disconnect power before installing or servicing control. High voltage electrical input is needed for this equipment. A qualified electrician should perform this work.

Before connecting power to the unit, read and understand the entire section of this document. As-built wiring diagrams are furnished with each control by the factory and are attached to the module's door.

When installed, the appliance must be electrically grounded in accordance with local codes, or in the absence of local codes, with the National Electrical Code, ANSI/NFPA 70, and/or the Canadian Electrical Code, CSA C22.1, if an external electrical source is utilized. Verify the voltage and phase of the power supply, and the wire amperage capacity is in accordance with the unit nameplate. Refer to **Table 10** for wire size and amperage ratings.

- **Always disconnect power before working on or near a unit. Lock and tag the disconnect switch and/or breaker to prevent accidental power-up.**
- The main electrical feed should be brought through one of the conduit openings located in the base of the unit, within the perimeter of the curb. When installing wiring and conduit, make sure to route in front of the gas train. **DO NOT ROUTE WIRING WITHIN THE SUPPLY OR RETURN DUCT. KEEP WIRING AND CONDUIT AT LEAST 1" AWAY FROM THE BURNER EXHAUST VENT. Refer to Figure 21 on page 28.**
- A dedicated branch circuit should supply the unit with short circuit protection according to the National Electric Code.
- Make certain that the power source is compatible with the requirements of your equipment. The unit nameplate identifies the proper phase and voltage of the equipment.
- Units shipped with an optional remote HMI panel have separate wiring requirements. It is important to run the main electrical wires in a separate conduit from the remote control HMI wiring. The HMI wiring is Cat-5 and must be separate from power cable. Maximum distance on any low voltage wire is 1000 feet.
- Before connecting the unit to the building power source, verify power line wiring is de-energized.
- Secure the power cables to prevent contact with sharp objects.
- Do not kink power cable and never allow the cable to come in contact with oil, grease, hot surfaces, or chemicals.
- Before powering up the unit, check fan wheel for free rotation and make sure that the interior of the heater is free of loose debris or shipping materials.
- If any of the original wire supplied with the appliance needs to be replaced, it must be replaced with wiring material having a temperature rating of at least 149°F and type TW wire or equivalent.
- **Seal ALL base penetrations with an appropriate filler (caulk or all-purpose putty) to prevent water from entering the space. Refer to Figure 21.**

WARNING: Low Voltage Wiring Should Never Route Together With High Voltage Wiring.

Table 10 - Copper Wire Ampacity

Wire Size	Maximum Amps
14 AWG	15
12 AWG	20
10 AWG	30
8 AWG	50
6 AWG	65
4 AWG	85
3 AWG	100
2 AWG	115
1 AWG	130

Wire Size	Maximum Amps
1/0 AWG	150
2/0 AWG	175
3/0 AWG	200
4/0 AWG	230
250 MCM	255
300 MCM	285
350 MCM	310
400 MCM	335
500 MCM	380
600 MCM	420

Building to Unit Power Wiring Connection

NOTE: Only Use Copper Wiring for Disconnect.

Figure 21 - Conduit Termination/Disconnect Switch Wiring

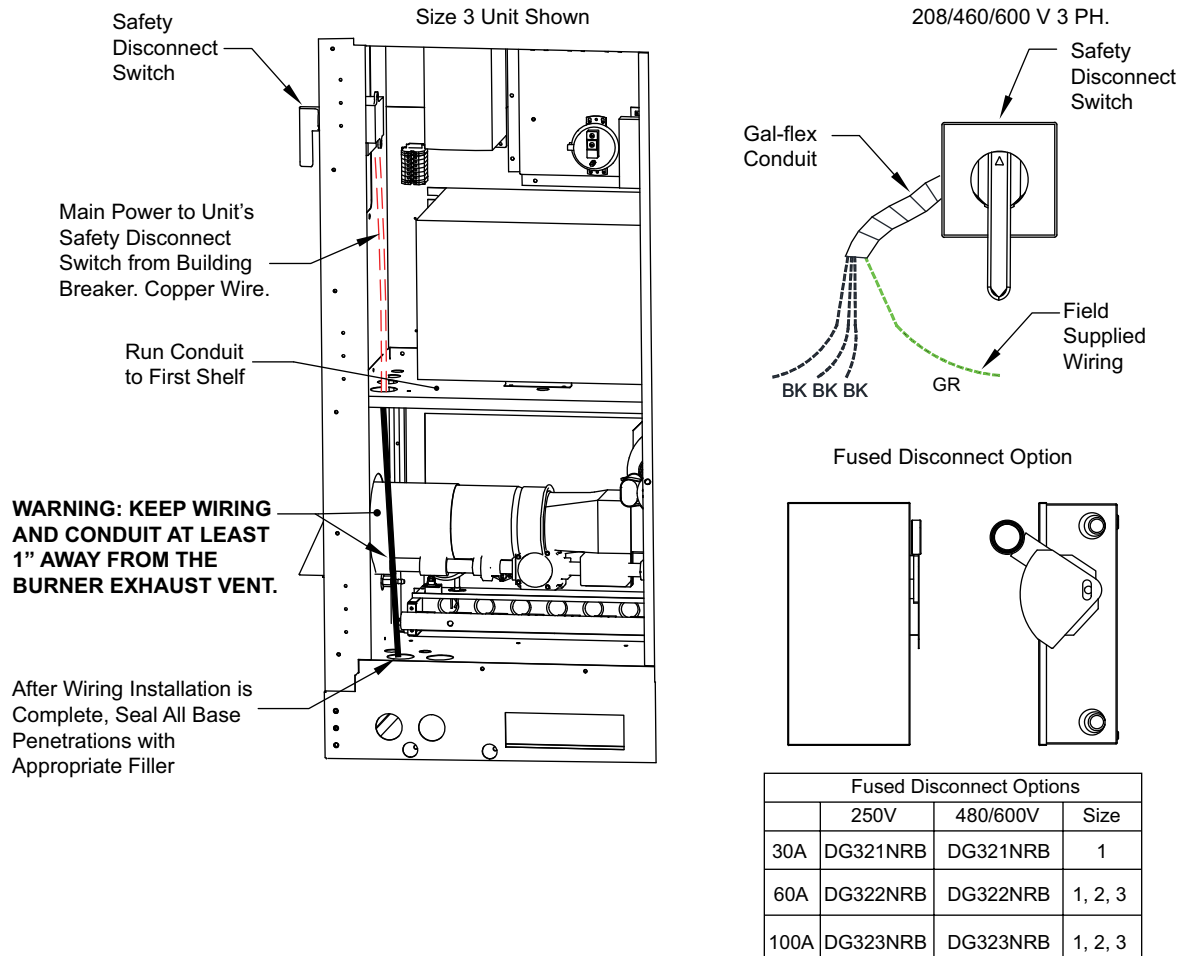

Site Preparation – Controls

- Consider general service and installation space when locating the remote temperature control.
- Locate the control as close to the space/fan that it will serve to reduce long, unnecessary wire runs.
- Install thermostats in locations that will produce a good representation of the air being moved by the fan in the space. Avoid thermostat installations in direct sunlight, near HVAC supplies, or abnormal temperature airstreams.

Typical Wiring Schematic

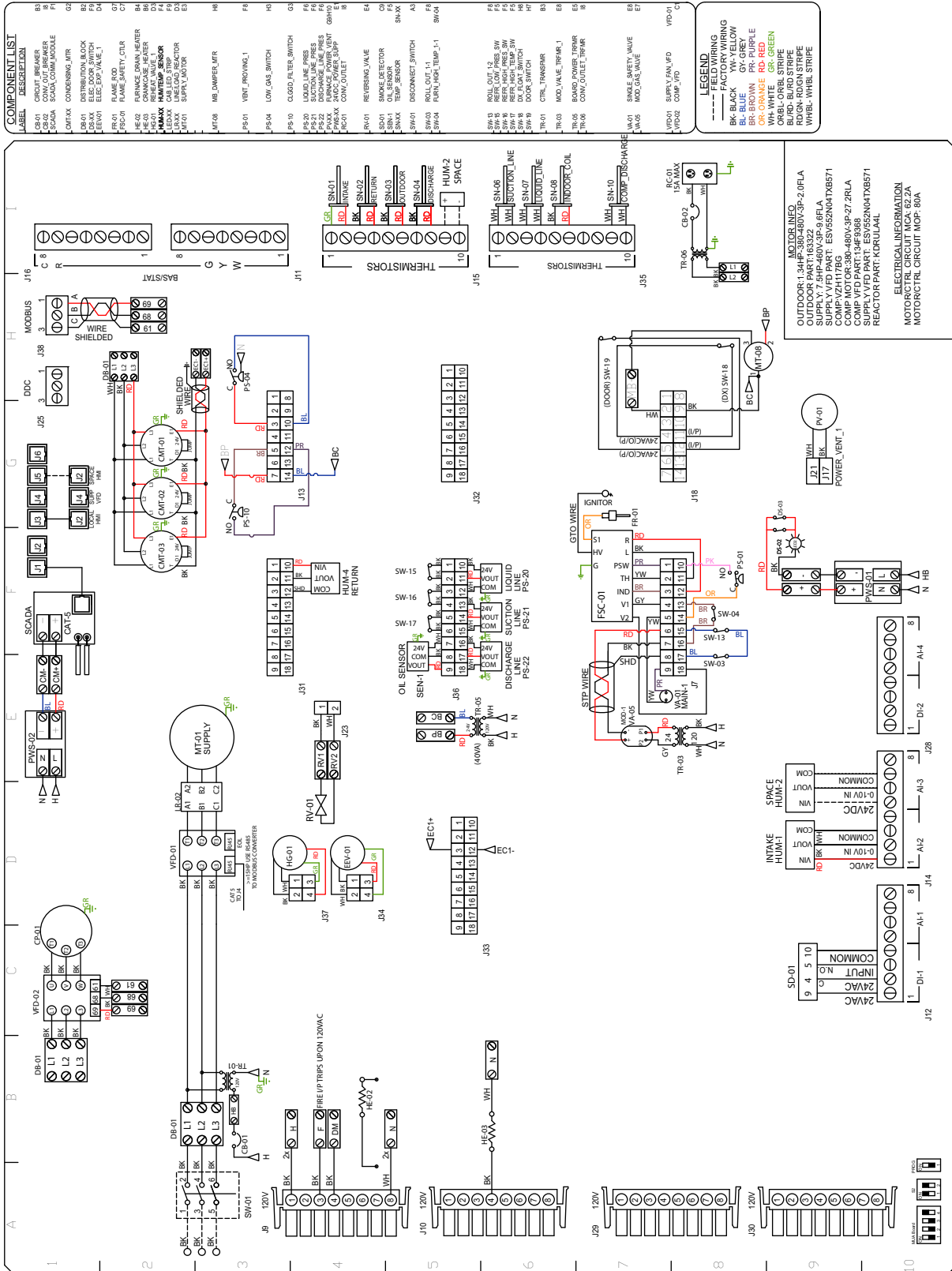

Variable Frequency Drive (VFD)

WARNING!

- Before installing the VFD drive, ensure the input power supply to the drive is OFF.
- The power supply and motor wiring of the VFD must be completed by a qualified electrician.
- The VFD is factory programmed, only change if replaced or ordered separately.

Consult the VFD manual and all documentation shipped with the unit for proper installation and wiring of the VFD. The VFD has been programmed by the factory with ordered specific parameters. Refer to **Table 11** during installation.

Table 11 - VFD Installation Check List

Check Off	Description
	The installation environment conforms to the VFD manual.
	The drive is mounted securely.
	Space around the drive meets the drive's specification for cooling.
	The motor and driven equipment are ready to start.
	The drive is properly grounded.
	The input power voltage matches the drive's nominal input voltage.
	The input power connections at L1, L2, and L3 are connected and tight.
	The input power protection is installed.
	The motor power connection at U, V, and W are connected and tight.
	The input, motor, and control wiring are run in separate conduit runs.
	The control wiring is connected and tight.
	NO tools or foreign objects (such as drill shavings) are in the drive.
	NO alternative power source for the motor (such as a bypass connection) is connected - NO voltage is applied to the output of the drive.

Variable Frequency Drive (VFD) Installation

Input AC Power

- Circuit breakers feeding the VFDs are recommended to be thermal-magnetic and fast-acting. They should be sized based on the VFD amperage and according to “**ACTECH SMV VFD**” on **page 32**. Refer to the installation schematic for exact breaker sizing.
- Every VFD should receive power from its own breaker. If multiple VFDs are to be combined on the same breaker, each drive should have its own protection measure (fuses or miniature circuit breaker) downstream from the breaker.
- Input AC line wires should be routed in conduit from the breaker panel to the drives. AC input power to multiple VFDs can be run in a single conduit if needed. **Do not combine input and output power cables in the same conduit.**
- The VFD should be grounded on the terminal marked PE. A separate insulated ground wire must be provided to each VFD from the electrical panel. This will reduce the noise being radiated in other equipment.

ATTENTION: Do not connect incoming AC power to output terminals U, V, W. Severe damage to the drive will result. Input power must always be wired to the input L terminal connections (L1, L2, L3).

VFD Output Power

- Motor wires from each VFD to its respective motor **MUST** be routed in a **separate steel** conduit away from control wiring and incoming AC power wiring. This is to avoid noise and crosstalk between drives. An insulated ground must be run from each VFD to its respective motor. Do not run different fan output power cables in the same conduit.
- VFD mounted in fan: The load reactor should be sized accordingly when the VFD is mounted in the fan.
 - 208/230V** - Load reactor is optional but recommended for 15 HP and above motors.
 - 460/480V** - Load reactor is optional but recommended for 7.5 HP and above motors.
 - 575/600V** - Load reactors are required for all HP motors.
- Do not install a contactor between the drive and the motor. Operating such a device while the drive is running can potentially cause damage to the power components of the drive.
- When a disconnect switch is installed between the drive and motor, the disconnect should only be operated when the drive is in a STOP state.

VFD Programming

Programming

1. The Drive should be programmed for the proper motor voltage. P107 is set to 0 (Low) if motor voltage is 120V AC, 208V AC or 400V AC. P107 is set to 1 (High) if the motor voltage is 230V AC, 480V AC, or 575V AC.
2. The Drive should be programmed for the proper motor overload value. P108 is calculated as Motor FLA x 100 / Drive Output Rating (available in “**ACTECH SMV VFD**” on page 32).

To enter the PROGRAM mode to access the parameters:

1. Use the buttons on the VFD screen to adjust VFD settings (**Figure 22**). Press the Mode (M) button. This will activate the password prompt (PASS).
2. Use the Up and Down buttons to scroll to the password value (the factory default password is “0225”) and press the Mode (M) button. Once the correct password is entered, the display will read “P100”, which indicates that the PROGRAM mode has been accessed at the beginning of the parameter menu.
3. Use the Up and Down buttons to scroll to the desired parameter number.
4. Once the desired parameter is found, press the Mode (M) button to display the present parameter setting. The parameter value will begin blinking, indicating that the present parameter setting is being displayed. The value of the parameter can be changed by using the Up and Down buttons.
5. Pressing the Mode (M) button will store the new setting and exit the PROGRAM mode. To change another parameter, press the Mode (M) button again to re-enter the PROGRAM mode. If the Mode button is pressed within 1 minute of exiting the PROGRAM mode, the password is not required to access the parameters. After one minute, the password must be re-entered to access the parameters again.

P500 parameter provides a history of the last 8 faults on the drive. It can be accessed without entering PROGRAM mode.

Figure 22 - VFD Screen

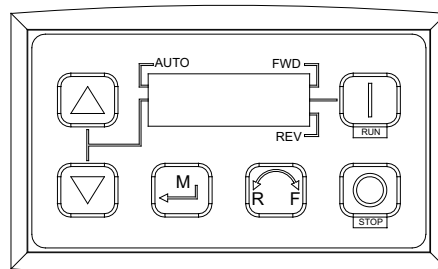

ACTECH SMV VFD

Table 12 - Cross-Reference

HP	Part Number	Volts	1Ø Input	3Ø Input	Input Amps 1Ø 120V AC	Input Amps 1Ø 240V AC	Output Amps	Breaker 1Ø 120V AC	Breaker 1Ø 240V AC
0.5	ESV371N01SXB571	120/240V	X	-	9.2	4.6	2.4	15	15
1	ESV751N01SXB571	120/240V	X	-	16.6	8.3	4.2	25	15
1.5	ESV112N01SXB571	120/240V	X	-	20	10	6	30	20

HP	Part Number	Volts	1Ø Input	3Ø Input	Input Amps 1Ø	Input Amps 3Ø	Output Amps	Breaker 1Ø	Breaker 3Ø
0.5	ESV371N02YXB571	240V	X	X	5.1	2.9	2.4	15	15
1	ESV751N02YXB571	240V	X	X	8.8	5	4.2	15	15
1.5	ESV112N02YXB571	240V	X	X	12	6.9	6	20	15
2	ESV152N02YXB571	240V	X	X	13.3	8.1	7	25	15
3	ESV222N02YXB571	240V	X	X	17.1	10.8	9.6	30	20
5	ESV402N02TXB571	240V	-	X	-	18.6	16.5	-	30
7.5	ESV552N02TXB571	240V	-	X	-	26	23	-	40
10	ESV752N02TXB571	240V	-	X	-	33	29	-	50
15	ESV113N02TXB571	240V	-	X	-	48	42	-	80
20	ESV153N02TXB571	240V	-	X	-	59	54	-	90
480V									
1	ESV751N04TXB571	480V	-	X	-	2.5	2.1	-	15
1.5	ESV112N04TXB571	480V	-	X	-	3.6	3	-	15
2	ESV152N04TXB571	480V	-	X	-	4.1	3.5	-	15
3	ESV222N04TXB571	480V	-	X	-	5.4	4.8	-	15
5	ESV402N04TXB571	480V	-	X	-	9.3	8.2	-	15
7.5	ESV552N04TXB571	480V	-	X	-	12.4	11	-	20
10	ESV752N04TXB571	480V	-	X	-	15.8	14	-	25
15	ESV113N04TXB571	480V	-	X	-	24	21	-	40
20	ESV153N04TXB571	480V	-	X	-	31	27	-	50
25	ESV183N04TXB571	480V	-	X	-	38	34	-	70
30	ESV223N04TXB571	480V	-	X	-	45	40	-	80
40	ESV303N04TXB571	480V	-	X	-	59	52	-	100
50	ESV373N04TXB571	480V	-	X	-	74	65	-	125
60	ESV453N04TXB571	480V	-	X	-	87	77	-	150
600V									
1	ESV751N06TXB571	600V	-	X	-	2	1.7	-	15
2	ESV152N06TXB571	600V	-	X	-	3.2	2.7	-	15
3	ESV222N06TXB571	600V	-	X	-	4.4	3.9	-	15
5	ESV402N06TXB571	600V	-	X	-	6.8	6.1	-	15
7.5	ESV552N06TXB571	600V	-	X	-	10.2	9	-	20
10	ESV752N06TXB571	600V	-	X	-	12.4	11	-	20
15	ESV113N06TXB571	600V	-	X	-	19.7	17	-	30
20	ESV153N06TXB571	600V	-	X	-	25	22	-	40
25	ESV183N06TXB571	600V	-	X	-	31	27	-	50
30	ESV223N06TXB571	600V	-	X	-	36	32	-	60
40	ESV303N06TXB571	600V	-	X	-	47	41	-	70
50	ESV373N06TXB571	600V	-	X	-	59	52	-	90
60	ESV453N06TXB571	600V	-	X	-	71	62	-	110

Make-up Air (MUA) Board Connectors

The Make-up Air Board (**Figure 23**) is located in the main cabinet, refer to **Figure 25** for location. Circuit 1 Cooling inputs/outputs are located on the MUA Board. Circuit 2/3 Cooling inputs/outputs are located on the Advanced Cooling Board (ACB).

Figure 23 - MUA Board

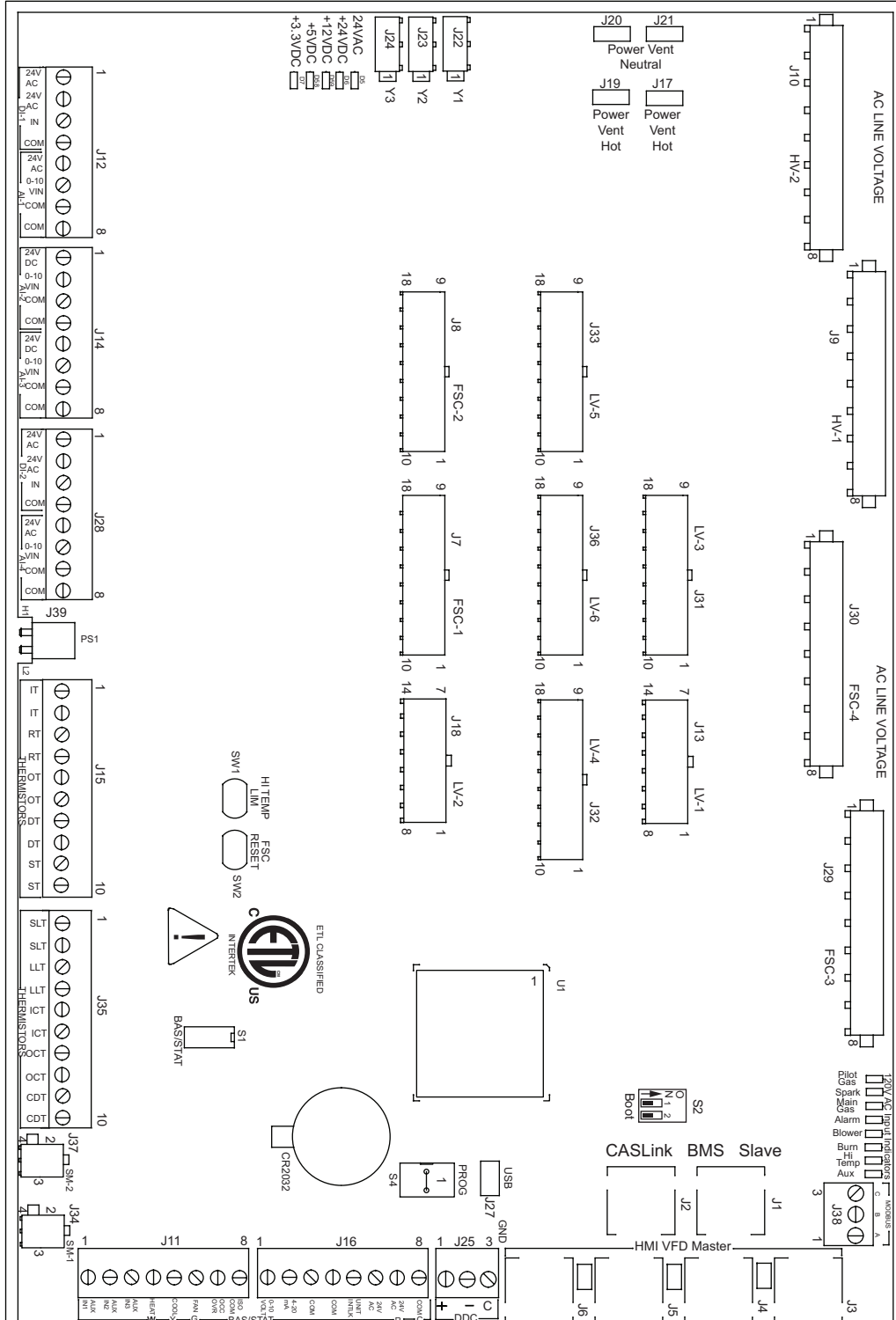

NOTE: Some connections may not be used dependent on system configurations

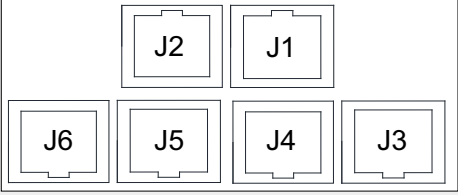
<p>RJ45 connectors</p> <p>Connector J1 and J2 are associated with BMS.</p> <p>Connector J3 through J6 are interchangeable and may be used to connect to an HMI or VFD.</p>	
<p>J1 - CASLink/Slave J2 - CASLink/Slave J3 - HMI/VFD/Master</p>	<p>J4 - HMI/VFD/Master J5 - HMI/VFD/Master J6 - HMI/VFD/Master</p>

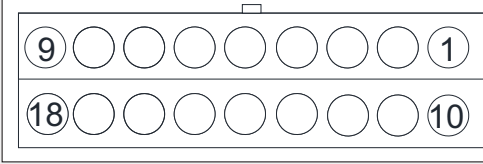
<p>Connector J7 contains inputs and outputs for the Flame Safety Controller (FSC)</p>	
<p>Pin 1 - 24VAC Output to Pressure Switch Input (PSW) on FSC or Electric Heater (option) Pin 2 - 24VAC Output to Thermostat Input (TH/W) on FSC Pin 3 - 24VAC Input from IND on FSC Pin 4 - 24VAC Input from V1 on FSC Pin 5 - 24VAC Output to Main Gas Valve (Connected to J7-4) Pin 6 - 0-10VDC + Analog Output to Modulating Gas Valve Pin 7 - 0-10VDC - Output to Modulating Gas Valve Pin 8 - Modulating Gas Valve Shield Pin 9 - 24VAC Common to Main/Pilot Gas Valve</p>	<p>Pin 10 - 24VAC Input from Vent Proving Switch (J7-1) / Electric Heat Dry Contact Pin 11 - 24VAC Output (L1) on FS Pin 12 - 24VAC Supply Power (R) on FSC Pin 13 - 24VAC Out to High Limit Switch Pin 14 - 24VAC Out to Vent Proving Switch Pin 15 - Detects 24VAC Presence from Roll Out Switch Pin 16 - Detects 24VAC Presence from High Limit Switch Pin 17 - 24VAC Out to Roll Out Switch Pin 18 - Valve Ground (V2) on FSC/High Efficiency (HE) Furnace Relay (RE-B)</p>

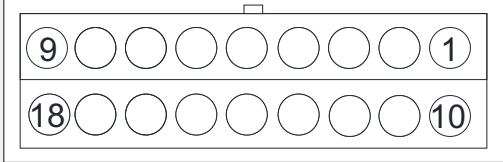
<p>Connector J8 contains inputs and outputs for the Flame Safety Controller (FSC)</p>	
<p>Pin 1 - 24VAC Output to Pressure Switch Input (PSW) on FSC or Electric Heater (option) Pin 2 - 24VAC Output to Thermostat Input (TH/W) on FSC Pin 3 - Detects 24VAC Presence from IND on FSC Pin 4 - 24VAC Input from V1 on FSC Pin 5 - 24VAC Output to Main Gas Valve (Connected to J8-4) Pin 6 - 0-10VDC + Analog Output to Modulating Gas Valve Pin 7 - 0-10VDC - Output to Modulating Gas Valve Pin 8 - Modulating Gas Valve Shield Pin 9 - 24VAC Common to Main/Pilot Gas Valve</p>	<p>Pin 10 - 24VAC Input from Vent Proving Switch (J8-1) / Electric Heat Dry Contact Pin 11 - 24VAC Output (L1) on FSC Pin 12 - 24VAC Supply Power (R) on FSC Pin 13 - 24VAC Output to High Limit Switch Pin 14 - 24VAC Output to Vent Proving Switch Pin 15 - Detects 24VAC Presence from Roll Out Switch Pin 16 - Detects 24VAC Presence from High Limit Switch Pin 17 - 24VAC Output to Roll Out Switch Pin 18 - Valve Ground (V2) on FSC/High Efficiency (HE) Furnace Relay (RE-B)</p>

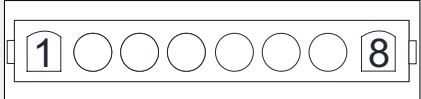
<p>Connector J9 contains 120V AC connections</p>	
<p>Pin 1 - 120VAC Main Input Pin 2 - N/A Pin 3 - 120VAC Input from Fire Microswitch Pin 4 - 120VAC Output to Intake/Discharge Damper Actuator</p>	<p>Pin 5 - 120VAC Input from Intake Damper End Switch Pin 6 - 120VAC Output to Drain Heater Pin 7 - 120VAC Output to Cabinet Heater Pin 8 - 120VAC Neutral</p>

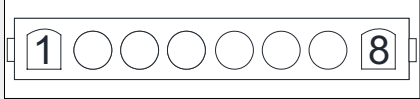
<p>Connector J10 contains 120V AC connections</p>	
<p>Pin 1 - N/A Pin 2 - N/A Pin 3 - 120VAC Output to Hot Water Solenoid Pin 4 - 120VAC Output to Chilled Water Solenoid/ Crankcase Heater</p>	<p>Pin 5 - 120VAC Input Supply Overload Pin 6 - 120VAC Output to Supply Starter/Purge Dry Relay Pin 7 - 120VAC Output to Exhaust Starter Pin 8 - 120VAC Neutral</p>

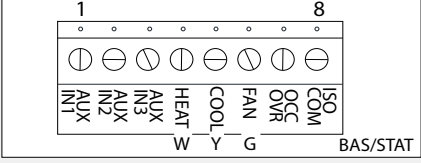
<p>Connector J11 contains low voltage screw terminal connections</p>	
<p>Pin 1 - 24VAC Auxiliary Input/Purge Mode Pin 2 - 24VAC Auxiliary Input Pin 3 - 24VAC Auxiliary Input Pin 4 - 24VAC Call for Heat Input</p>	<p>Pin 5 - 24VAC Call for Cooling Input Pin 6 - 24VAC Call for Blower Input Pin 7 - 24VAC Occupied Override Input Pin 8 - 24VAC Isolated Common</p>

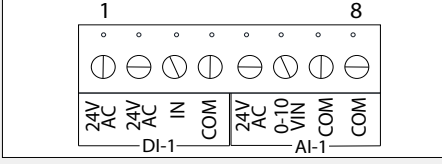
<p>Connector J12 contains low voltage screw terminal connections</p>	
<p>Pin 1 - 24VAC Output to Smoke Detector Pin 2 - 24VAC Output to Smoke Detector Pin 3 - 24VAC Digital Input from Smoke Detector Pin 4 - 24VAC Common to Smoke Detector</p>	<p>Pin 5 - 24VAC Output to Air Quality Sensor Pin 6 - 0-10V Analog Input from Air Quality Sensor Pin 7 - 24VAC Common to Air Quality Sensor Pin 8 - 24VAC Common to Air Quality Sensor</p>

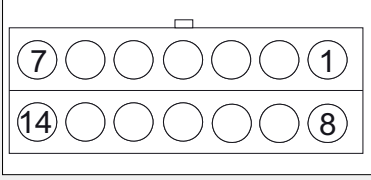
<p>Connector J13 contains low voltage connections</p>	
<p>Pin 1 - N/A Pin 2 - PWM + Output for Supply ECM Pin 3 - 24VAC Output for Low Gas Pressure Switch Pin 4 - 24VAC Output for High Gas Pressure Switch Pin 5 - 24VAC Output for Clogged Filter Switch Pin 6 - 24VAC Output for Low Airflow Pin 7 - 24VAC Input for Board Power Pin 8 - N/A</p>	<p>Pin 9 - N/A Pin 10 - 24VAC Input from Low Gas Pressure Switch Pin 11 - 24VAC Input from High Gas Pressure Switch Pin 12 - 24VAC Input from Clogged Filter Switch Pin 13 - 24VAC Input from Low Air Pressure Switch Pin 14 - 24VAC for Board Power</p>

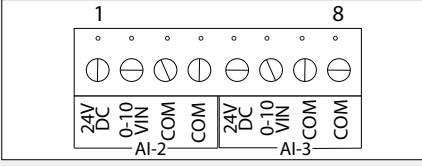
<p>Connector J14 contains screw terminal connections</p>	
<p>Pin 1 - 24VAC Output to Intake RH Pin 2 - 0-10VDC Analog Input from Intake RH Pin 3 - 24VAC Common to Intake RH Pin 4 - 24VAC Common to Humidity Sensor</p>	<p>Pin 5 - 24VAC Output to Space RH Pin 6 - 0-10VDC Analog Input from Space RH Pin 7 - 24VAC Common to Space RH Pin 8 - 24VAC Common to Humidity Sensor</p>

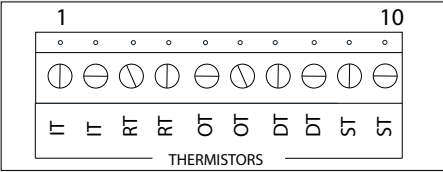
<p>Connector J15 contains low voltage connections</p>	
<p>Pin 1 - Intake Temperature Thermistor Input Pin 2 - Intake Temperature Thermistor Input Pin 3 - Return Temperature Thermistor Input Pin 4 - Return Temperature Thermistor Input Pin 5 - Outdoor Temperature Thermistor Input</p>	<p>Pin 6 - Outdoor Temperature Thermistor Input Pin 7 - Discharge Temperature Thermistor Input Pin 8 - Discharge Temperature Thermistor Input Pin 9 - Space Temperature Thermistor Input Pin 10 - Space Temperature Thermistor Input</p>

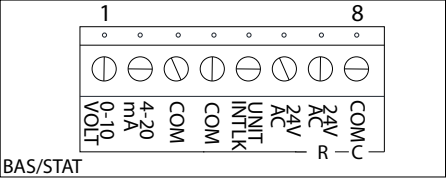
<p>Connector J16 contains low voltage screw terminal connections</p>	
<p>Pin 1 - 0-10VDC Analog Input Pin 2 - 4-20 mA Analog Input Pin 3 - 24VAC Common Pin 4 - 24VAC Common</p>	<p>Pin 5 - 24VAC Unit Interlock Input Pin 6 - 24VAC Output Stat tied to J12-7 Pin 7 - 24VAC Output (R) tied to J12-6 Pin 8 - 24VAC Common</p>

NOTE: Connector J17 is grouped with connectors J-19 through J-21

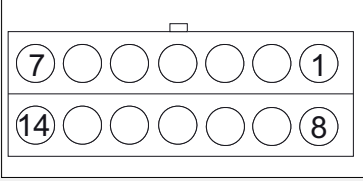
<p>Connector J18 contains low voltage connections</p>	
<p>Pin 1 - 24VDC + Output for Spare Pin 2 - 0-10VDC Analog Output for Mixing Box Actuator Pin 3 - 0-10VDC Analog Output for Bypass Damper/Powered Exhaust Pin 4 - 24VAC Output for DX Float Switch Pin 5 - 24VAC Output for Door Interlock Pin 6 - 24VAC Extreme Low Ambient Bypass Solenoid Output Pin 7 - 24VAC for Damper Actuator Pin 8 - 24VDC - Common for Spare</p>	<p>Pin 9 - 0-10VDC Analog Output for Mixing Box Actuator Pin 10 - 0-10VDC Analog Output for Bypass Damper/Powered Exhaust Pin 11 - 24VAC Input from DX Float Switch Pin 12 - 24VAC Input from Door Interlock Pin 13 - 24VAC Extreme Low Ambient Bypass Solenoid Common Pin 14 - 24VAC for Damper Actuator</p>

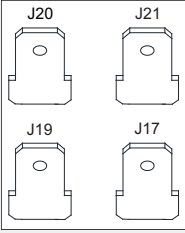
<p>Connector J17 Output for Power Vent 1 Connector J19 Output for Power Vent 2 Connector J20 Neutral for Power Vent Connector J21 Neutral for Power Vent</p>	
<p>J17 - 120VAC Output for Power Vent 1 J19 - 120VAC Output for Power Vent 2</p>	<p>J20 - 120VAC Neutral for Power Vents J21 - 120VAC Neutral for Power Vents</p>

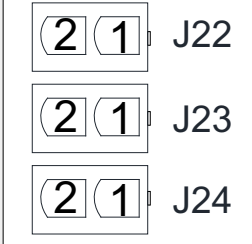
<p>Connector J22 (Y1) N/A Connector J23 (Y2) Reversing Valve Connector J24 (Y3) N/A</p>	
<p>J22 Pin 1 - N/A J22 Pin 2 - N/A J23 Pin 1 - 24VAC Output to Reversing Valve 1</p>	<p>J23 Pin 2 - 24VAC Common to Reversing Valve 1 J24 Pin 1 - N/A J24 Pin 2 - N/A</p>

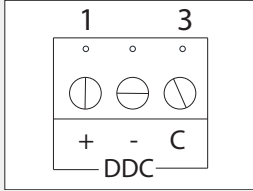
<p>Connector J25 contains low voltage screw terminal connections for DDC Communications Isolated</p>	
<p>Pin 1 - RS-485 + Pin 2 - RS-485 -</p>	<p>Pin 3 - RS-485 Common</p>

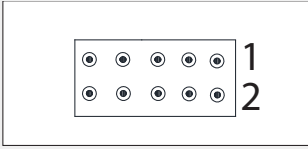
<p>Connector J26 Programming Port</p>	
--	--

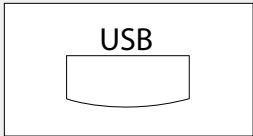
<p>Connector J27 USB Programming Port</p>	
--	---

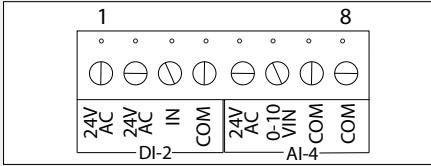
<p>Connector J28 contains low voltage screw terminal connections</p>	
<p>Pin 1 - 24VAC Output Pin 2 - 24VAC Output Pin 3 - 24VAC Digital Input Pin 4 - 24VAC Common</p>	<p>Pin 5 - 24VAC Output to Supply Fan Pin 6 - 0-10VDC Analog Input Supply Fan Speed Pin 7 - 24VAC Common to Supply Fan Pin 8 - 24VAC Common to Supply Fan</p>

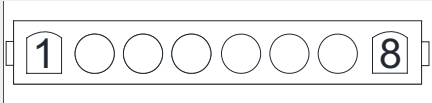
<p>Connector J29 contains 120V AC connections</p>	
<p>N/A</p>	

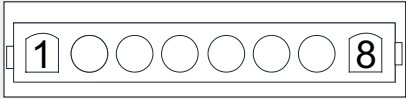
<p>Connector J30 contains 120V AC connections</p>	
<p>Pin 1 through Pin 7 - N/A</p>	<p>Pin 8 - 120VAC Alarm Output</p>

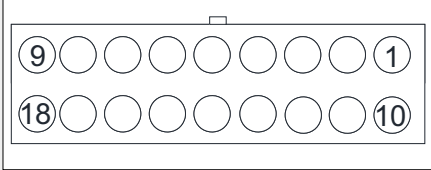
<p>Connector J31 contains inputs and outputs for components</p>	
<p>Pin 1 - 24VDC + Output to Outdoor RH Sensor Pin 2 - 0-10VDC Analog Input from Outdoor RH Sensor Pin 3 - 24VDC/0-10VDC Common from Outdoor RH Sensor Pin 4 - 24VDC + Output to Inlet Gas Pressure Sensor Pin 5 - 0-10VDC Analog Input from Inlet Gas Pressure Sensor Pin 6 - 24VDC/0-10VDC Common from Inlet Gas Pressure Sensor Pin 7 - 24VDC + Output to Discharge RH Sensor Pin 8 - 0-10VDC Analog Input from Discharge RH Sensor Pin 9 - 24VDC/0-10VDC Common from Discharge RH Sensor</p>	<p>Pin 10 - 24VDC + output to Return RH Sensor Pin 11 - 0-10VDC Analog Input from Return RH Sensor Pin 12 - 24VDC/0-10VDC Common from Return RH Sensor Pin 13 - 24VDC + output to Clogged Filter Pressure Sensor Pin 14 - 0-10VDC Analog Input from Clogged Filter Pressure Sensor Pin 15 - 24VDC/0-10VDC Common from Clogged Filter Pressure Sensor Pin 16 - 24VDC + Output for Analog or Static Pressure Control for Blower/Damper Pin 17 - 0-10VDC Analog Input for Analog or Static Pressure Control for Blower/Damper Pin 18 - 24VDC/0-10VDC Common for Analog or Static Pressure Control for Blower/Damper</p>

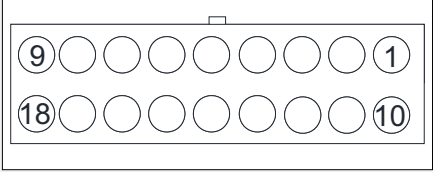
<p>Connector J32 contains inputs and outputs for components</p>	
<p>Pin 1 - 24VAC Output for High Air Airflow Switch Pin 2 - PWM + Output for Exhaust/Power Vent ECM Pin 3 - 24VAC Output for Proof Of Closure / HE Furnace Float Switch Pin 4 - 24VDC + Output for Exhaust Current Sensor Pin 5 - 24VAC Output To CO Alarm Pin 6 - 0-24VDC + Analog Input from Flame Sensor Pin 7 - 24VDC Powered PWM to Modulating Gas Valve, Full Wave, 16 kHz Pin 8 - 0-10VDC Analog Output Pin 9 - 0-10VDC Analog Output for Electric Heat</p>	<p>Pin 10 - 24VAC Input from High Airflow Switch Pin 11 - PWM - Output for Exhaust/Power Vent ECM Pin 12 - 24VAC Input from Proof of Closure / HE Furnace Float Switch Pin 13 - 4-20mA Input from Exhaust Current Sensor Pin 14 - 24VAC From CO Alarm Pin 15 - 24VDC Common From Flame Sensor Pin 16 - 24VDC Powered PWM to Modulating Gas Valve, Full Wave, 16 kHz Pin 17 - 0-10VDC Analog Output Pin 18 - 0-10VDC Analog Output for Electric heat</p>

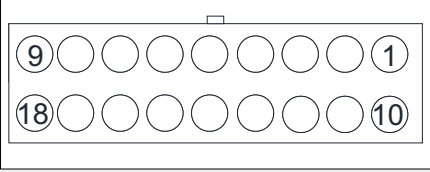
<p>Connector J33 contains inputs and outputs for components</p>	
<p>Pin 1 - 24VDC + Output for Main Unit Current Sensor Pin 2 - 24VDC + Output for Cooling Current Sensor Pin 3 - PWM + Output for Condenser Fans 1 Pin 4 - PWM + Output for Condenser Fans 2 Pin 5 - PWM + Input for Spare 1 Pin 6 - 24VDC + Pulse Input from Gas Meter Pin 7 - 24VDC + Pulse Input from Water Meter Pin 8 - 24VAC Output to Oil Solenoid Pin 9 - N/A</p>	<p>Pin 10 - 4-20mA Input from Main Unit Current Sensor Pin 11 - 4-20mA Input from Cooling Current Sensor Pin 12 - PWM - Output for Condenser Fans 1 Pin 13 - PWM - Output for Condenser Fans 2 Pin 14 - PWM - Input for Spare 1 Pin 15 - PWM - Pulse Input from Gas Meter Pin 16 - 24VDC - Pulse Input from Water Meter Pin 17 - 24VAC Common for Oil Solenoid Pin 18 - N/A</p>

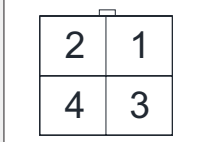
<p>Connector J34 Stepper Motor (EEV)</p>	
<p>Pin 1 - Stepper Motor 1, 12V, Bipolar Pin 2 - Stepper Motor 1, 12V, Bipolar</p>	<p>Pin 3 - Stepper Motor 1, 12V, Bipolar Pin 4 - Stepper Motor 1, 12V, Bipolar</p>

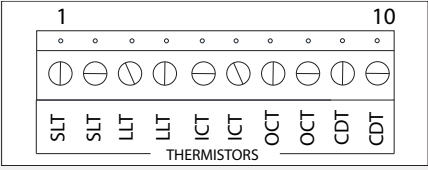
<p>Connector J35 contains low voltage connections</p>	
<p>Pin 1 - Suction Line Thermistor Input Pin 2 - Suction Line Thermistor Input Pin 3 - Liquid Line Thermistor Input Pin 4 - Liquid Line Thermistor Input Pin 5 - Evap/Indoor Thermistor Input</p>	<p>Pin 6 - Evap/Indoor Thermistor Input Pin 7 - Condenser/Outdoor Coil Thermistor Input Pin 8 - Condenser/Outdoor Coil Thermistor Input Pin 9 - Compressor Discharge Thermistor Input Pin 10 - Compressor Discharge Thermistor Input</p>

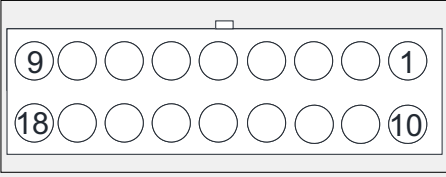
<p>Connector J36 contains inputs and outputs for components</p>	
<p>Pin 1 - 24VAC Output for Low Pressure Switch Pin 2 - 24VAC Input for Low Pressure Switch Pin 3 - 24VAC Output for High Pressure Switch Pin 4 - 24VAC Input for Low Pressure Switch Pin 5 - 24VAC Output for High Temp Switch Pin 6 - 24VAC Input for Low Pressure Switch Pin 7 - 24VAC Output to Oil Sensor Pin 8 - 24VAC Common from Oil Sensor Pin 9 - 24VAC Input from Oil Sensor</p>	<p>Pin 10 - 24VDC + output to Liquid Line Pressure Transducer Pin 11 - 0-10VDC Analog Input from Liquid Line Pressure Transducer Pin 12 - 24VDC/0-10VDC Common from Liquid Line Pressure Transducer Pin 13 - 24VDC + Output to Suction Line Pressure Transducer Pin 14 - 0-10VDC Analog Input from Suction Line Pressure Transducer Pin 15 - 24VDC/0-10VDC Common from Suction Line Pressure Transducer Pin 16 - 24VDC + output to Discharge Line Pressure Transducer Pin 17 - 0-10VDC Analog Input from Discharge Line Pressure Transducer Pin 18 - 24VDC/0-10VDC Common from Discharge Line Pressure Transducer</p>

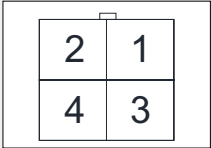
<p>Connector J37 Stepper Motor (Reheat Valve)</p>	
<p>Pin 1 - Stepper Motor 2, 12V, Bipolar Pin 2 - Stepper Motor 2, 12V, Bipolar</p>	<p>Pin 3 - Stepper Motor 2, 12V, Bipolar Pin 4 - Stepper Motor 2, 12V, Bipolar</p>

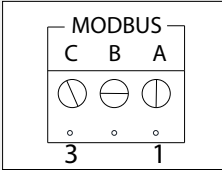
<p>Connector J38 Modbus</p>	
<p>Pin 1 (A) - Modbus (-) Pin 2 (B) - Modbus (+)</p>	<p>Pin 3 (C) - Modbus Ground</p>

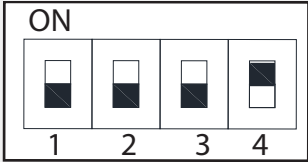
<p>Dip Switch S1</p>	
<p>Switch 1, 2, 3 always OFF. Switch 4 Always ON. If Switch 4 is OFF, BAS terminals disabled.</p>	

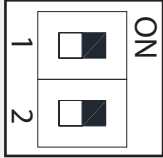
<p>Dip Switch S2</p>	
<p>Programming - Service Only</p>	

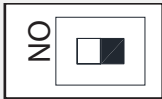
<p>Dip Switch S3</p>	
<p>End of line termination</p>	

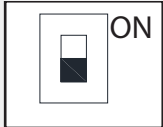
<p>Dip Switch S4</p>	
<p>Programming - Service Only</p>	

ACB Connectors

The Advanced Cooling Board (ACB) (Figure 24) is located in the main cabinet, refer to Figure 25 for location. Circuit 1 Cooling inputs/outputs are located on the MUA Board. Circuit 2/3 Cooling inputs/outputs are located on the ACB.

Figure 24 - Advanced Cooling Board (ACB)

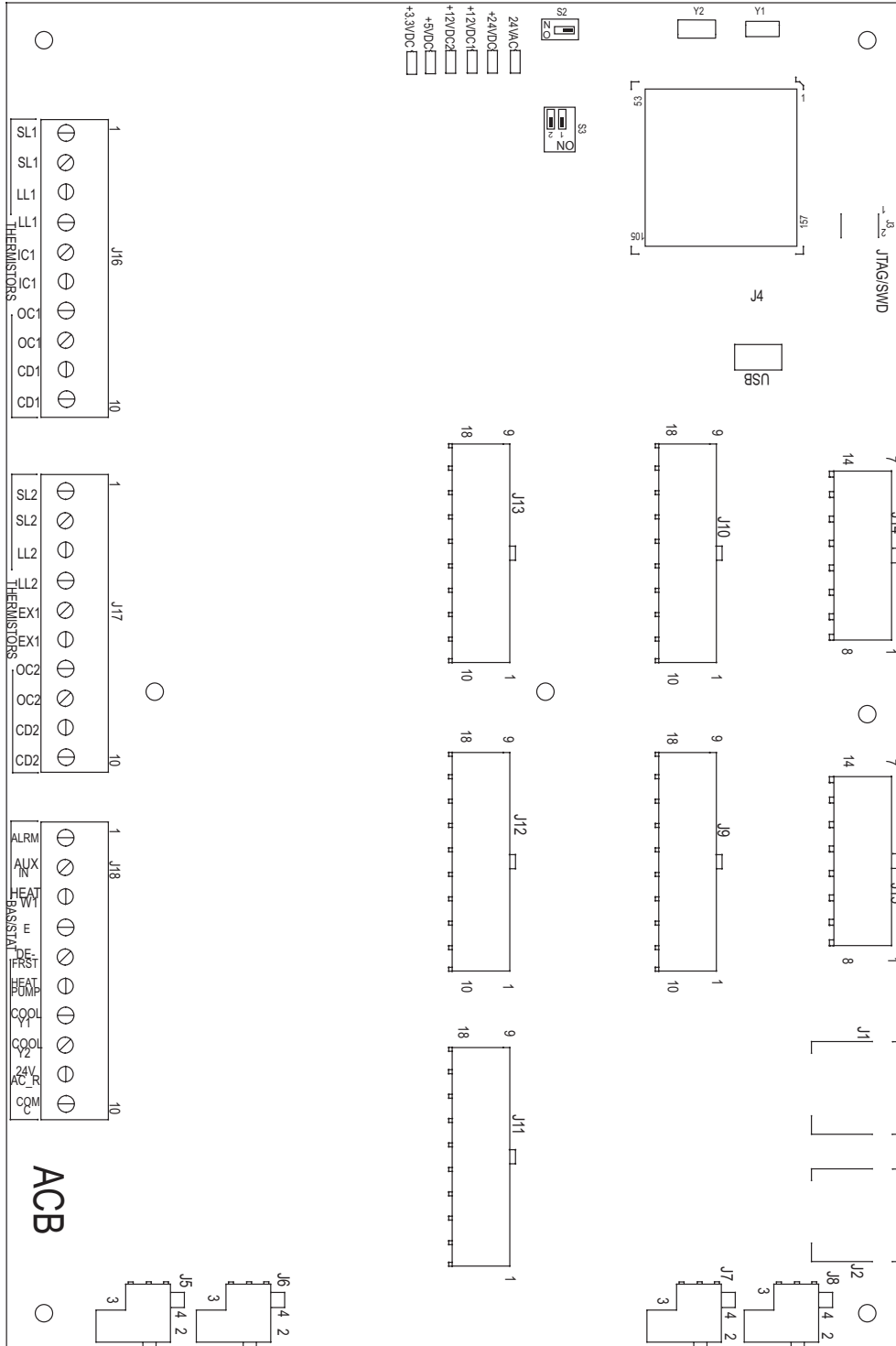

NOTE: Some connections may not be used dependent on system configurations

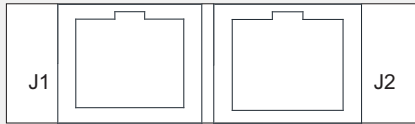
<p>RJ45 connectors Connector J1 and J2 are associated with BMS. Connector J3 through J6 are interchangeable and may be used to connect to an HMI or VFD.</p>	
<p>J1 - CASLink/Slave</p>	<p>J2 - HMI/VFD/Master</p>

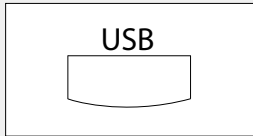
<p>Connector J4 USB Programming Port</p>	
---	---

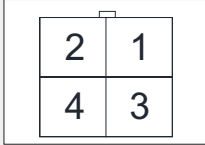
<p>Connector J5 Stepper Motor (EEV 1) (EEV 1 = Circuit 2)</p>	
<p>Pin 1 - Stepper Motor 1, 12V, Bipolar Pin 2 - Stepper Motor 1, 12V, Bipolar</p>	<p>Pin 3 - Stepper Motor 1, 12V, Bipolar Pin 4 - Stepper Motor 1, 12V, Bipolar</p>

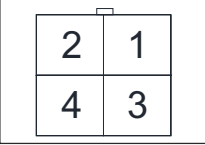
<p>Connector J6 Stepper Motor (EEV 2) (EEV 2 = Circuit 3)</p>	
<p>Pin 1 - Stepper Motor 2, 12V, Bipolar Pin 2 - Stepper Motor 2, 12V, Bipolar</p>	<p>Pin 3 - Stepper Motor 2, 12V, Bipolar Pin 4 - Stepper Motor 2, 12V, Bipolar</p>

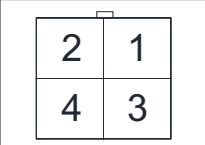
<p>Connector J7 Stepper Motor (Reheat Valve 1) (Reheat Valve 1 = Circuit 2)</p>	
<p>Pin 1 - Stepper Motor 1, 12V, Bipolar Pin 2 - Stepper Motor 1, 12V, Bipolar</p>	<p>Pin 3 - Stepper Motor 1, 12V, Bipolar Pin 4 - Stepper Motor 1, 12V, Bipolar</p>

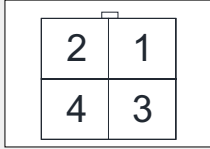
<p>Connector J8 Stepper Motor (Reheat Valve 2) (Reheat Valve 2 = Circuit 3)</p>	
<p>Pin 1 - Stepper Motor 2, 12V, Bipolar Pin 2 - Stepper Motor 2, 12V, Bipolar</p>	<p>Pin 3 - Stepper Motor 2, 12V, Bipolar Pin 4 - Stepper Motor 2, 12V, Bipolar</p>

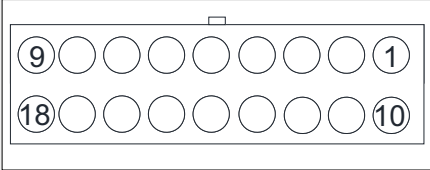
<p>Connector J9 contains inputs and outputs for components</p>	
<p>Pin 1 - 24VDC + output to Discharge Line Pressure Transducer 1 Pin 2 - 0-10VDC Analog Input from Discharge Line 1 Pressure Sensor Pin 3 - 24VDC/0-10VDC Common from Discharge Line 1 Pressure Sensor Pin 4 - 24VDC + output to Suction Line Pressure Transducer 1 Pin 5 - 0-10VDC Analog Input from Suction Line 1 Pressure Sensor Pin 6 - 24VDC/0-10VDC Common from Suction Line 1 Pressure Sensor Pin 7 - 24VDC + output to Liquid Line Pressure Transducer 1 Pin 8 - 0-10VDC Analog Input from Liquid Line 1 Pressure Sensor Pin 9 - 24VDC/0-10VDC Common from Liquid Line 1 Pressure Sensor</p>	<p>Pin 10 - 24VAC constant output to High Pressure Switch Compressor 1 Pin 11 - 24VAC Input for High Pressure Switch Compressor 1 Pin 12 - 24VAC constant output to Low Pressure Switch Compressor 1 Pin 13 - 24VAC Input for Low Pressure Switch Compressor 1 Pin 14 - 24VAC constant output to Discharge Temp Compressor 1 Pin 15 - 24VAC Input for High Discharge Temp Compressor 1 Pin 16 - PWM + Output for Condensing Fan Group 1 Pin 17 - PWM - Output for Condensing Fan Group 1 Pin 18 - 24VAC Output Notification For Compressor 1</p>

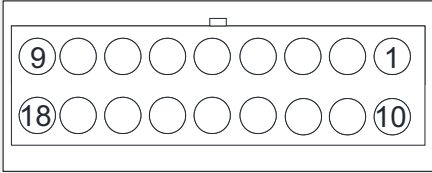
<p>Connector J10 contains inputs and outputs for components</p>	
<p>Pin 1 - 24VDC + output to Discharge Line Pressure Transducer 2 Pin 2 - 0-10VDC Analog Input from Discharge Line 2 Pressure Sensor Pin 3 - 24VDC/0-10VDC Common from Discharge Line 2 Pressure Sensor Pin 4 - 24VDC + output to Suction Line Pressure Transducer 2 Pin 5 - 0-10VDC Analog Input from Suction Line 2 Pressure Sensor Pin 6 - 24VDC/0-10VDC Common from Suction Line 2 Pressure Sensor Pin 7 - 24VDC + output to Liquid Line Pressure Transducer 2 Pin 8 - 0-10VDC Analog Input from Liquid Line 2 Pressure Sensor Pin 9 - 24VDC/0-10VDC Common from Liquid Line 2 Pressure Sensor</p>	<p>Pin 10 - 24VAC constant output to High Pressure Switch Compressor 2 Pin 11 - 24VAC Input for High Pressure Switch Compressor 2 Pin 12 - 24VAC constant output to Low Pressure Switch Compressor 2 Pin 13 - 24VAC Input for Low Pressure Switch Compressor 2 Pin 14 - 24VAC constant output to Discharge Temp Compressor 2 Pin 15 - 24VAC Input for High Discharge Temp Compressor 2 Pin 16 - PWM + Output for Condensing Fan Group 2 Pin 17 - PWM - Output for Condensing Fan Group 2 Pin 18 - 24VAC Output Notification For Compressor 2</p>

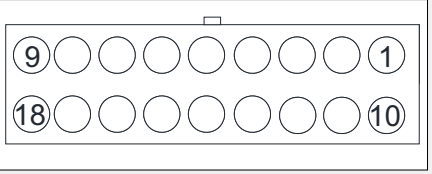
<p>Connector J11 contains low voltage connections</p>	
<p>Pin 1 - 24VAC Input for Board Power Pin 2 - 24VAC Common for Board Power Pin 3 - 24VAC Output to Spare 1 Pin 4 - 24VAC Common to Spare 1 Pin 5 - PWM + Output for Spare 1 Pin 6 - PWM - Output for Spare 1 Pin 7 - 24VDC + Output for Evap RH Sensor Pin 8 - 0-10VDC Analog Input from Evap Coil RH Sensor Pin 9 - 24VDC/0-10VDC Common from Evap Coil RH Sensor</p>	<p>Pin 10 - 24VDC + Output for ERV Exhaust RH Sensor Pin 11 - 0-10VDC Analog Input from ERV Exhaust Air RH Sensor Pin 12 - 24VDC/0-10VDC Common from ERV Exhaust Air RH Sensor Pin 13 - 24VDC + Output for Spare 2 Pin 14 - 0-10VDC Analog Input for Spare 2 Pin 15 - 24VDC/0-10VDC Common for Spare 2 Pin 16 - 24VDC + Output for Spare 3 Pin 17 - 0-10VDC Analog Input for Spare 3 Pin 18 - 24VDC/0-10VDC Common for Spare 3</p>

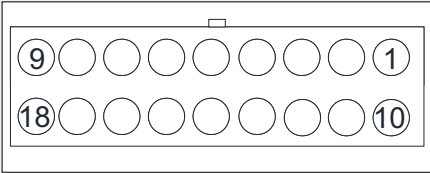
<p>Connector J12 contains inputs and outputs for components</p>	
<p>Pin 1 - 24VAC Output to Compressor 1 Pin 2 - 24VAC Output to Oil Solenoid 1 Pin 3 - 24VAC Constant Output to Compressor 1 Overload Pin 4 - 24VAC Output to Reversing Valve 1 Pin 5 - 24VDC + Output for Compressor 1 Current Sensor Pin 6 - 24VDC + Output for Condensing Fan 1 Current Sensor Pin 7 - 24VAC Input from Compressor 1 VFD Pin 8 - 24VAC Output for Oil Sensor Control Voltage 1</p>	<p>Pin 9 - 24VAC Input for Compressor 1 Phase Protection Pin 10 - 24VAC Common to Compressor 1 Pin 11 - 24VAC Common to Oil Solenoid 1 Pin 12 - 24VAC Input for Compressor 1 Overload Pin 13 - 24VAC Common to Reversing Valve 1 Pin 14 - 4-20mA Input from Compressor 1 Current Sensor Pin 15 - 4-20mA Input from Condensing Fan 1 Current Sensor Pin 16 - 24VAC Output to Compressor 1 VFD Pin 17 - 24VAC Input for Oil Sensor 1 Pin 18 - 24VAC Common for Oil Sensor 1</p>

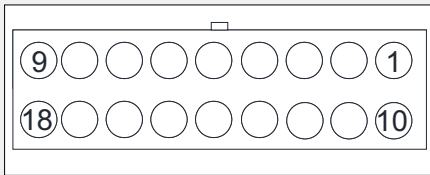
<p>Connector J13 contains inputs and outputs for components</p>	
<p>Pin 1 - 24VAC Output to Compressor 2 Pin 2 - 24VAC Output to Oil Solenoid 2 Pin 3 - 24VAC Constant Output to Compressor 2 Overload Pin 4 - 24VAC Output to Reversing Valve 2 Pin 5 - 24VDC + Output for Compressor 2 Current Sensor Pin 6 - 24VDC + Output for Condensing Fan 2 Current Sensor Pin 7 - 24VAC Input from Compressor 2 VFD Pin 8 - 24VAC Output for Oil Sensor Control Voltage 2</p>	<p>Pin 9 - 24VAC Input for Compressor 2 Phase Protection Pin 10 - 24VAC Common to Compressor 2 Pin 11 - 24VAC Common to Oil Solenoid 2 Pin 12 - 24VAC Input for Compressor 2 Overload Pin 13 - 24VAC Common to Reversing Valve 2 Pin 14 - 4-20mA Input from Compressor 2 Current Sensor Pin 15 - 4-20mA Input from Condensing Fan 2 Current Sensor Pin 16 - 24VAC Output to Compressor 2 VFD Pin 17 - 24VAC Input for Oil Sensor 2 Pin 18 - 24VAC Common for Oil Sensor 2</p>

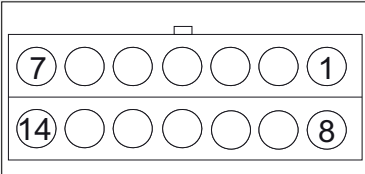
<p>Connector J14 N/A</p>	
---------------------------------	--

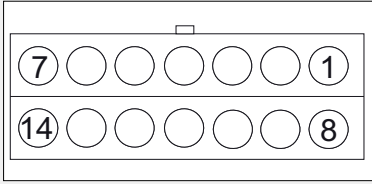
<p>Connector J15 N/A</p>	
---------------------------------	--

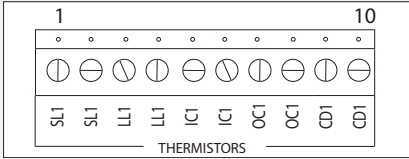
<p>Connector J16 contains low voltage screw terminal connections</p>	
<p>Pin 1 - Suction Line Circuit 1 Temperature Input Pin 2 - Suction Line Circuit 1 Temperature Input Pin 3 - Liquid Line Circuit 1 Temperature Input Pin 4 - Liquid Line Circuit 1 Temperature Input Pin 5 - Evap/Indoor Coil 1 Temperature Input Pin 6 - Evap/Indoor Coil 1 Temperature Input</p>	<p>Pin 7 - Condenser/Outdoor Coil 1 Thermistor Input Pin 8 - Condenser/Outdoor Coil 1 Thermistor Input Pin 9 - Compressor Discharge Line Circuit 1 Temperature Input Pin 10 - Compressor Discharge Line Circuit 1 Temperature Input</p>

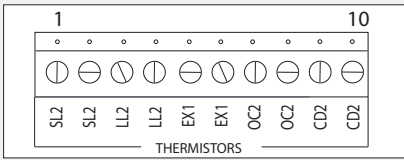
<p>Connector J17 contains low voltage screw terminal connections</p>	
<p>Pin 1 - Suction Line Circuit 2 Temperature Input Pin 2 - Suction Line Circuit 2 Temperature Input Pin 3 - Liquid Line Circuit 2 Temperature Input Pin 4 - Liquid Line Circuit 2 Temperature Input Pin 5 - Evap/Indoor Coil 2 Temperature Input Pin 6 - Evap/Indoor Coil 2 Temperature Input</p>	<p>Pin 7 - Condenser/Outdoor Coil 2 Thermistor Input Pin 8 - Condenser/Outdoor Coil 2 Thermistor Input Pin 9 - Compressor Discharge Line Circuit 2 Temperature Input Pin 10 - Compressor Discharge Line Circuit 2 Temperature Input</p>

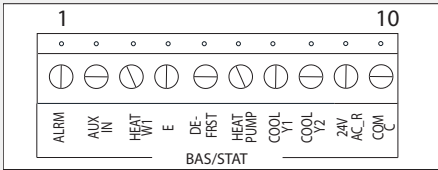
<p>Connector J18 contains low voltage connections</p>	
<p>Pin 1 - 24VAC Input for Alarm Pin 2 - 24VAC Input for AUX Pin 3 - 24VAC Call for Heat Stage 1 Input Pin 4 - 24VAC Call for Heat Stage 2/ Emergency Input Pin 5 - 24VAC Input for Defrost</p>	<p>Pin 6 - 24VAC Input for Heat Pump Reversing Valve Pin 7 - 24VAC Input for Cooling Stage 1 Pin 8 - 24VAC Input for Cooling Stage 2 Pin 9 - 24VAC Constant Output (R) Pin 10 - 24VAC Common/ Isolated Common Via Dip Switch</p>

Component Location

Use **Figure 25** through **Figure 32** for component locations. Units equipped with ERV, refer to “**Energy Recovery (Optional)**” on page 105 for component descriptions and locations.

Figure 25 - Typical Main Cabinet (Size 1-3)

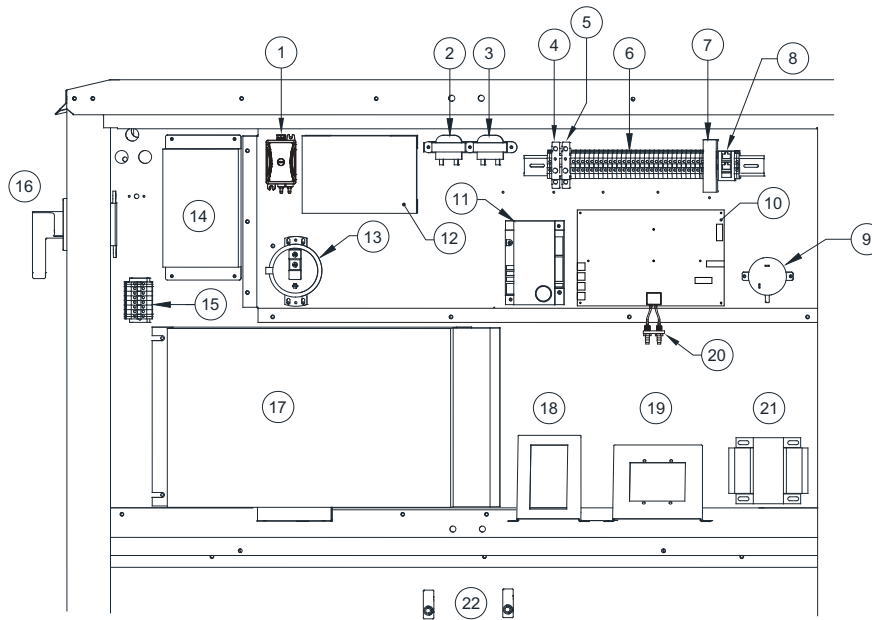

1. **Differential Pressure Transducer** – Monitors air pressure differential between two points. Used in different air control options.
2. **40VA 120V to 24V Transformer (TR-xx)** – Verify transformers on schematics, varies by application.
3. **20VA 120V to 24V Transformer (TR-xx)** – Verify transformers on schematics, varies by application.
4. **Convenience Outlet Circuit Breaker (CB-02)** – Protects transformer for convenience outlet from high current spikes.
5. **Circuit Breaker (CB-01)** – Protects electrical components from high current spikes.
6. **Terminal Strip** – Central location to terminate control wiring. Should be used for troubleshooting.
7. **24V DC Power Supply (PWS-01)** – Converts input voltage of **100-240 AC** to an output voltage of **24 DC**.
8. **RJ45 Converter** – Communication port for a Cat 5 cable that allows components to connect to other components.
9. **Induced Draft Air Sensor (PS-01)** – A safety device located near the draft inducer motor that will prevent operation of the furnace if correct venting air pressures are not detected.
10. **MUA Board** - Controls the **0-10V DC** signal to modulating furnace controls, modulating gas valve, and **24V AC** signals to staged furnace controls.
11. **Flame Safety Control (FSC-01)** – Initiates and monitors flame. Equipped with non-adjustable time settings for pre-purge, inter-purge, and post-purge of the exhaust flue and control cabinet.
12. **750V 230/460V to 120V Transformer** – Used for the convenience outlet. Voltage inputs 208/230/480.
13. **Clogged Filter Switch (PS-10)** – Senses whether the filters at the intake to the main supply motor are free of dirt and contaminant. Optional component.
14. **VFD Controller (VFD-01)** – Used to protect supply motor, and to control the speed of the motor to vary airflow across unit.
15. **Distribution Block** – Distributes power to condensing components.
16. **Disconnect Switch (SW-01)** – Controls all electrical power to the entire unit.
17. **Compressor Drive Frequency Converter (VFD-02)** – Operates the compressor.
18. **Compressor Local Control Panel (LCP)** – Used to navigate the compressor’s VFD controls.
19. **HMI Panel** – MUA board interface. The 4 buttons are used to navigate through the menu screens.
20. **Air Flow Reducers** – Connection between on-board air flow sensor to probe mounted in the cabinet.
21. **Convenience Outlet Transformer (TR-09)** – 2000VA transformer used for the convenience outlet. Voltage inputs 208/230/480.
22. **Door Switches (DS-xx)** – These switches operate the LED lights inside the cabinet.

Figure 26 - Typical Main Cabinet (Size 4)

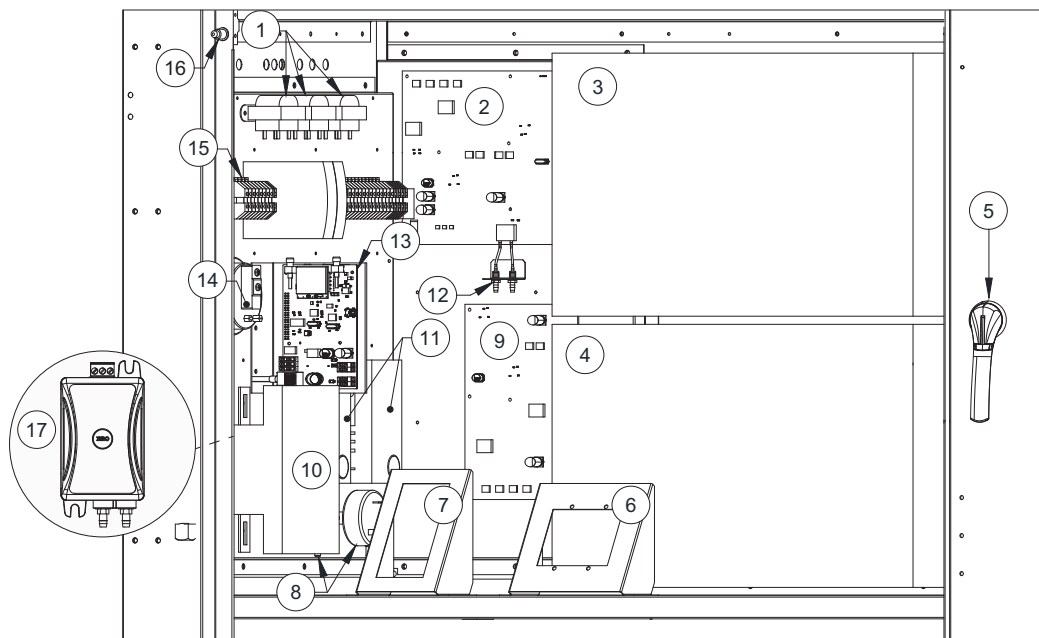

1. **Transformer (TR-xx)** – 40VA 120V to 24V/20VA 120V to 24V. Verify transformers on schematics, varies by application.
 2. **Make-Up Air (MUA) Board** - Controls the **0-10V DC** signal to modulating furnace controls, modulating gas valve, and **24V AC** signals to staged furnace controls.
 3. **Compressor Drive Frequency Converter (VFD-xx)** – Operates compressor 2. For 40/50T cooling units.
 4. **Compressor Drive Frequency Converter (VFD-xx)** – Operates compressor 1.
 5. **Disconnect Switch (SW-01)** – Controls all electrical power to the entire unit.
 6. **HMI Panel** – MUA board interface. The 4 buttons are used to navigate through the menu screens.
 7. **Compressor Local Control Panel (LCP)** – Used to navigate the compressor’s VFD controls.
 8. **Induced Draft Air Sensor (PS-xx)** – A safety device located near the draft inducer motor that will prevent operation of the furnace if correct venting air pressures are not detected. Quantity (1) for standard and high turndown furnace. Quantity (2) for 700/800mbh furnaces.
 9. **Advanced Cooling Board (ACB)** – The ACB is used on 40/50T cooling units.
 10. **750V 230/460V to 120V Transformer** – Used for controls. Voltage inputs 208/230/480.
 11. **Flame Safety Control (FSC-xx)** – Initiates and monitors flame. Equipped with non-adjustable time settings for pre-purge, inter-purge, and post-purge of the exhaust flue and control furnace. Quantity (1) sensor for standard and high turndown furnace. Quantity (2) for 700/800mbh furnaces.
 12. **Air Flow Reducers** – Connection between on-board air flow sensor to probe mounted in the cabinet.
 13. **SCADA Communication Module** – Communication module that relays product information to CASLink.
 14. **Clogged Filter Switch (PS-10)** – Senses whether the filters at the intake to the main supply motor are free of dirt and contaminant. This is an optional component.
 15. **Electrical Din Rail** - Contains the following electrical components:
 - **Convenience Outlet Circuit Breaker (CB-02)** – Protects transformer for convenience outlet from high current spikes. This is an optional component.
 - **Circuit Breaker (CB-01)** – Protects electrical components from high current spikes.
 - **Terminal Strip** – Central location to terminate control wiring. Should be used for field wiring.
 - **24V DC Power Supply (PWS-01)** – Converts input voltage of **100-240V AC** to an output voltage of **24V DC**.
 - **RJ45 Converter** – Communication port for a Cat 5 cable that allows components to connect to other components. This is an optional component.
 16. **Door Switch (DS-xx)** – This switch operate the LED lights inside the cabinet.
 17. **Differential Pressure Transducer** – Monitors the air pressure differential between two points. This transducer is used in different air control options. This is an optional component.
- Not Shown: **VFD Controller (VFD-01)** – Used to protect supply motor, and to control the speed of the motor to vary airflow across unit. Located below main cabinet.

Figure 27 - Typical Refrigerant Access Panel Heat Pump with Reheat shown

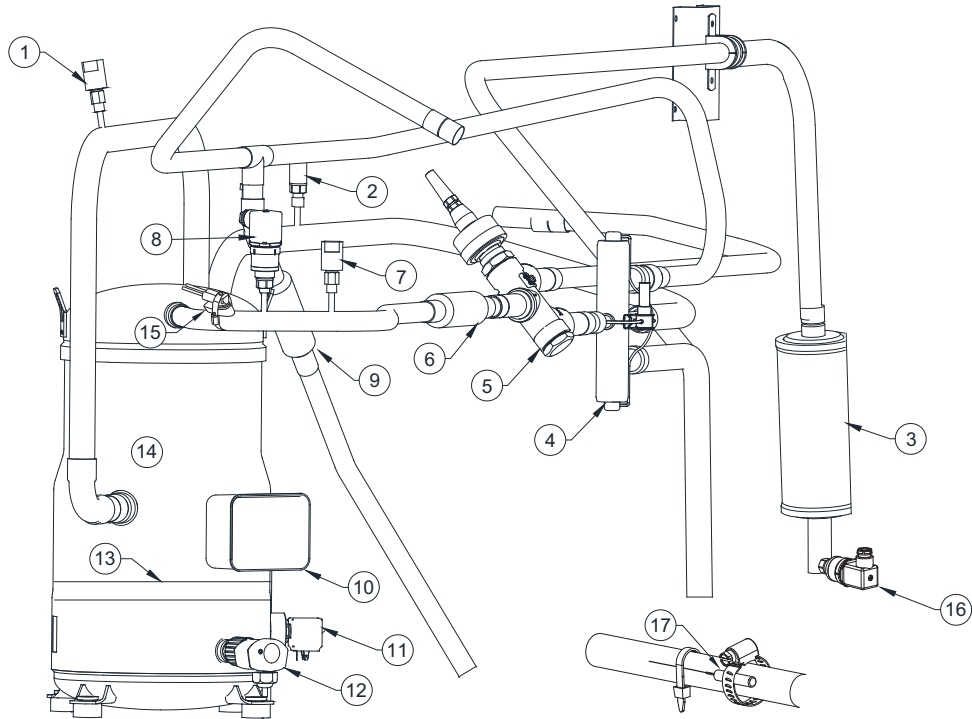

1. **Refrigerant Low Pressure Switch (SW-15)** – Detects refrigerant pressure on the low-pressure side of the system. If the pressure drops below the preset value, the compressor will shut down. This sensor has an automatic reset.
2. **Suction (Low) Line Pressure Sensor (PS-21)** – Transducer that monitors the low side of the refrigeration system.
3. **Filter/Drier** – Absorbs water and filters system contaminants.
4. **Reversing Valve (RV-01)** – A valve used for heat pump applications that changes the flow of refrigerant. By changing the flow of refrigerant, the heat pump cycle is changed from cooling to heating or heating to cooling.
5. **Hot Gas Reheat Valve(s)** – Valve(s) will modulate the supply of refrigerant to the outdoor (condensing) coil and to the reheat coil. Units with a single reheat valve, HG-01, will be a three-way valve. Units that use dual reheat valves, not shown, will have HG-01 in-line to the reheat coil inlet and HG-02 in-line to the outdoor (condensing) coil inlet.
6. **Discharge Check Valve** – Restricts liquid migration back to compressor during off cycles.
7. **Refrigerant High Pressure Switch (SW-16)** – If the pressure rises above the preset value, the compressor will shut down.
8. **Discharge (High) Pressure Transducer (PS-22)** – Transducer that monitors the high side of the refrigeration system.
9. **Reheat Coil Check Valve** – Restricts refrigerant flow to the reheat coil when reheat is not active.
10. **Compressor Power Termination** – Power connection from Compressor Drive Frequency Converter.
11. **Oil Return Solenoid Valve (OS-01)** – Allows oil to be distributed throughout the scroll set when activated. Not applicable to VZH-044/065 compressors.
12. **Oil Level Sensor (SEN-01)** – Monitors the oil level in the compressor. If the oil level is low, the unit will shut down.
13. **Crankcase Heater (HE-03)** – A heating cable used to boil off liquid refrigerant within the crank of the compressor.
14. **Compressor** – Circulates refrigerant throughout the system.
15. **Refrigerant High Temperature Switch (SW-18)** – This safety switch opens at dangerously high compressor discharge temperatures. For heat pump applications only.
16. **Liquid Line Pressure Sensor (PS-20)** – Pressure transducer that monitors the liquid line pressure in the refrigeration system.
17. **Suction/Discharge/Liquid Line Temperature Sensor** – A sensor mounted to copper piping. Mount the Suction/Discharge sensor horizontally at the 10 or 2 o'clock position. Mount the Liquid sensor with the wire harness on the bottom. Secure sensors with stainless steel hose clamp. Zip tie the wire harness. When installed, cover with cork insulation tape.

Not Shown:

- **High-Pressure Port** – High-pressure gauge connection port.
- **Low-Pressure Port** – Low-pressure gauge connection port.
- **Accumulator** – Prevents liquid flooding back to the compressor. Used in heat pump and certain cooling applications.

Figure 28 - Gas Furnace Cabinet

Typical Standard Gas Furnace

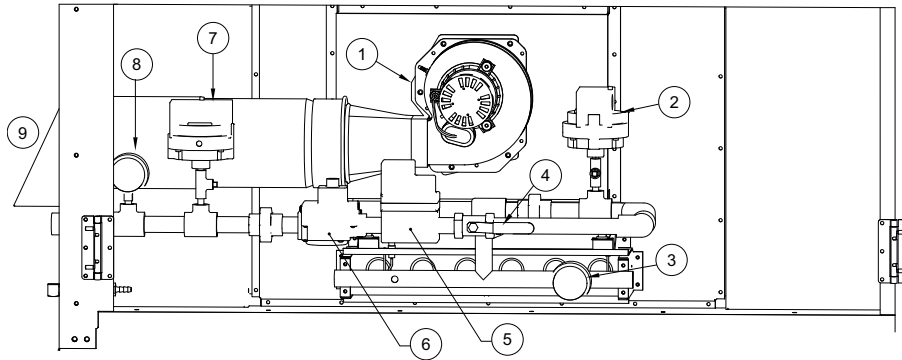

High Turndown Furnace Option

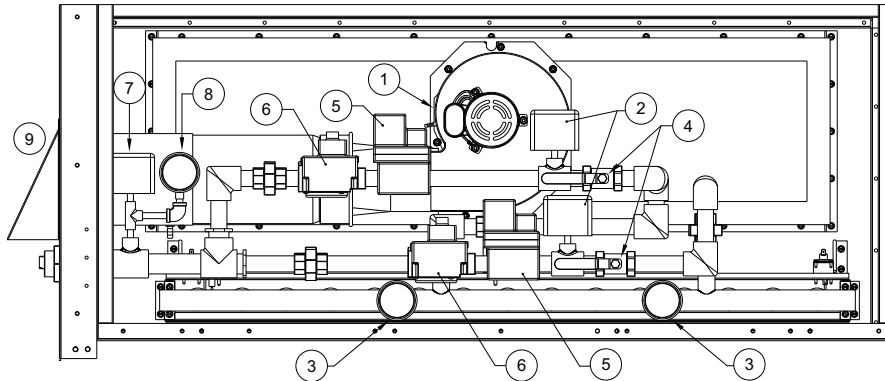

1. **Furnace Power Vent (PV-xx)** – An assembly used to exhaust flue gases.
2. **High-Pressure Gas Switch (PS-03)** – Monitors pressure and shuts down heating when pressures rise above the desired set point. This is an optional component.
3. **Manifold Gas Pressure Gauge (0-10" wc)** – Measures manifold gas pressure.
4. **Manual Gas Shut Off Valve** – Allows gas flow to burner. Shut off to leak test gas train.
5. **Modulating Gas Valve (VA-03)** – Controls the amount of gas to the furnace to meet desired discharge/space temperature.
6. **ON/OFF Gas Valve (VA-01)** – On/Off gas valve with built-in regulator and manual shut off switch.
7. **Low-Pressure Gas Switch (PS-04)** – Monitors pressure and shuts down heating when pressure drops below the desired set point. This is an optional component.
8. **Inlet Gas Pressure Gauge (0-35" wc)** – Measure inlet gas pressure.
9. For standard furnaces, a stainless steel type B vent will be used. For High Efficiency (HE) furnace, a PVC vent will be used. See "Furnace Condensation Drain" on page 18.

Figure 29 - Typical Burner Cabinet

Single Burner

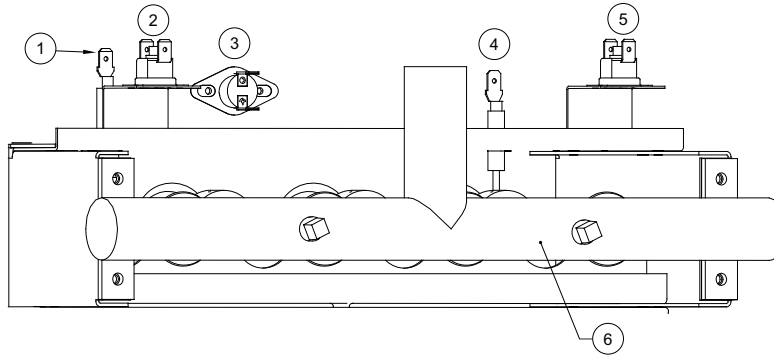

Split Burner

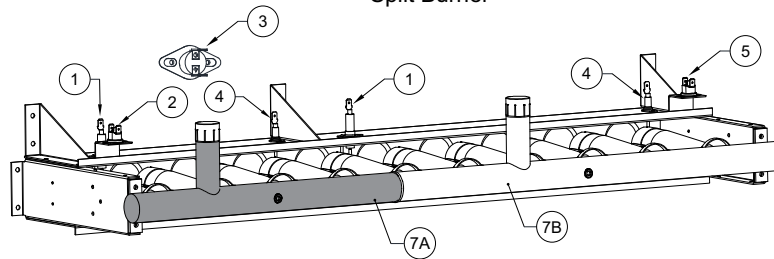

1. **Ignitor** – Powered by Flame Safety Control to initiate light-off.
2. **Rollout Switch 1 (SW-05)** – Normally closed temperature activated switch. Mounted on bracket at the firing tube. Senses flame roll-out in the event of a blocked tube, low airflow, or low gas pressure. If flame-rollout is present, the switch de-energizes heater circuit on the furnace. Must be manually reset by pressing the small button on top of the switch.
3. **Furnace High Temperature Switch (SW-04)** – Normally closed switch. De-energizes the heater circuit on the furnace if temperature exceeds mechanical set-point. Automatic recycling.
4. **Flame Rod (FR-01)** – Continuously senses for the presence of flame in heating mode after ignition has commenced. This sensor is wired to the Flame Safety Control (FSC-1).
5. **Rollout Switch 2 (SW-13)** – Normally closed temperature activated switch. Mounted on bracket at the firing tube. Senses flame roll-out in the event of a blocked tube, low airflow, or low gas pressure. If flame-rollout is present, the switch de-energizes heater circuit on the furnace. Must be manually reset by pressing the small button on top of the switch.
6. Single Burner Assembly – Capacity varies by unit size.
7. Split Furnace Assembly – Capacity varies by unit size. When the high turndown option is selected, a split furnace will be present.
 - A. First Stage – Smallest of the two stages. The first stage can modulate for the highest turndown.
 - B. Second Stage – When first stage is 100% operational, the second stage can modulate to meet the required heating capacity.

Figure 30 - Typical Damper Access Panel

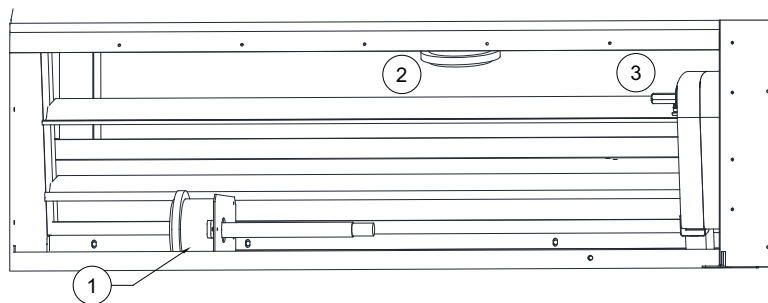

1. **Return Temperature and/or Humidity Sensor (SN-xx)** – Monitors the return air temperature and/or humidity.
2. **Outdoor Temperature Sensor (SN-xx)** – Monitors the outdoor temperature. Located behind outside air intake louvers.
3. **Intake Damper Assembly Motor (MT-xx)** – Provides control of the outside/return air damper assembly

Figure 31 - Typical Blower and Air Intake Access Doors/Panel

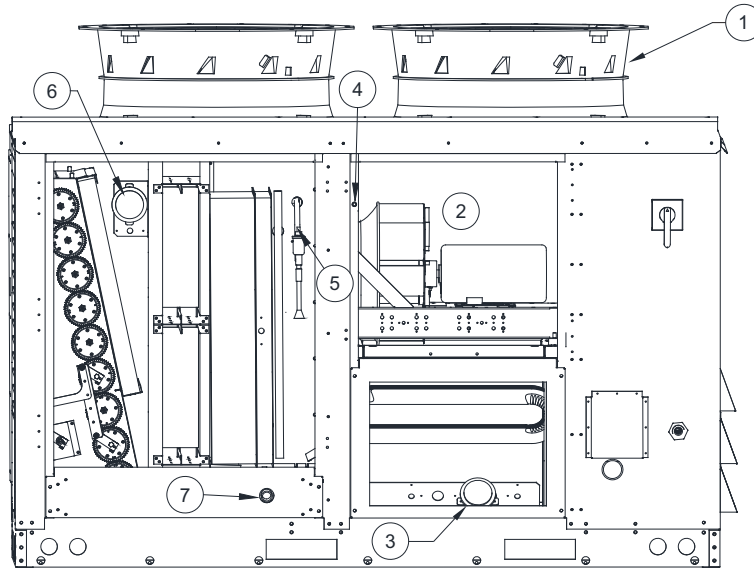

1. **Condensing Fan Motor (MT-xx)** – Pulls air across the outdoor coil.
 2. **Supply Motor (MT-01)** – Located behind door. Main supply air motor.
 3. **Discharge Temperature Sensor or Discharge Humidity/Temperature (SN-xx)** – Monitors discharge air temperature or humidity/temperature.
 4. **Door Tamper Switch (SW-19)** – When the blower door is open, the switch will de-activate the supply motor.
 5. **Electronic Expansion Valve (EEV-1)** – Controls the flow of refrigerant to maintain a desired superheat value.
 6. **Intake Temperature or Intake Humidity/Temperature Sensor (SN-xx/HUM-xx)** – Monitors intake air humidity/temperature.
 7. **Float Switch (SW-xx)** – Monitors the water level from condensation in the drain pan.
- Not Shown: **Evap Coil Temperature Sensor (SN-xx)** – Monitors the dew point temperature of the air before the reheat coil.

Optional Components

AC Interlock

On units equipped with the optional AC interlock, **24V AC** power from a rooftop unit should be field wired to screw terminal J11-(5) on the MUA board. **24V AC** common from a rooftop unit should be field wired to terminal block J11-(8) on the MUA board. When these terminals are powered, heat will be locked out on the RTU.

Burner Interlock

On units equipped with the optional burner interlock, **24V AC** power from a rooftop unit should be field wired to screw terminal J11-(4) on the MUA board. **24V AC** common from a rooftop unit should be field wired to terminal block J11-(8) on the MUA board. When these terminals are powered, cooling will be locked out on the RTU.

Electric Cabinet Heater

Units can be shipped with an optional **120V** electric cabinet heater powered from the MUA board. There is a temperature sensor built onto the MUA board that will regulate when the cabinet heater activates.

Communication Module

The Communication Module, PN: **SCADA**, is included in all CASlink equipped panels. It obtains operational data from various connected components. This communication wiring is either RS-485 shielded twisted pair wiring or RJ45 Cat 5 Ethernet wiring.

Electric Heater Option

The electric coils on the heater are controlled using Silicon Controller Rectifier (SCR) controls. SCR is a time proportioning type controller that modulates the heater and supplies the exact amount of power to match the heat demand.

The three black wires from the electric heater will need to be field wired to the disconnect switch.

Figure 32 - Electric Heater Option

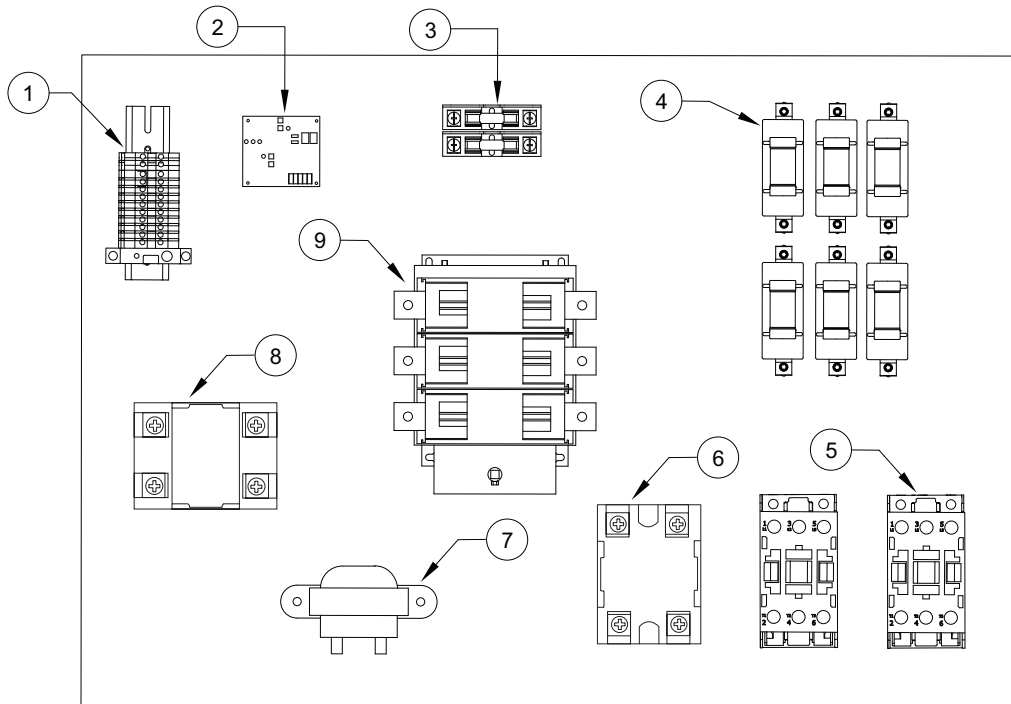

1. **Terminal Strip** – Central location to terminate control wiring. Should be used for troubleshooting.
2. **Stage Controller** – Controls multiple heating stages in a pre-determined sequence. Works in conjunction with a proportional thermostat (not shown). A sensor is mounted in the blower housing for discharge control. The set-point is mounted remotely for either space control or discharge control.
3. **Stage Fuses** - Protect the total load and/or individual heater stages.
4. **Mercury Contactor** – Provides power to the individual stages of the heater (optional for quieter operation).
5. **Coil Contactor** - Energizes coil when there is a signal from step controller.
6. **Magnetic Contactor** - Provides power to the individual stages of the heater.
7. **Transformer** - Supplies power to the control circuit. Supplied with a fuse.
8. **Solid State Relay (SSR)** - Proportionally controls the amount of power transmitted to the heating elements.
9. **Disconnect Switch** – Interrupts power to the electric coil.

Compressor Information

Oil return management – Insufficient lubrication can be the result of oil depositing itself in pipes and bends. Return management helps oil deposits to return to the crankcase by:

- Increasing velocity for short periods at regular time intervals.
- Providing adequate oil return when velocity is too low.

Timed oil boost – Returns oil from the system to the compressor for a defined time period. To set the oil boost configuration, go to **Factory Settings > Compressor Config > Oil Boost Time**. The user can set the time OFF or configure a time setting between 1-120 minutes. Default is set to 60 minutes. When the system is in an oil boost, the boost will last for 1 minute, and an “O” will be displayed on the HMI.

Oil level –When the compressor is running and in a stabilized condition, the oil level should be visible in the sight glass window, see **Figure 33**. The presence of small bubbles and foam indicates there could be a large concentration of refrigerant in the oil, or there may be liquid returning to the compressor.

Figure 33 - Sight Glass

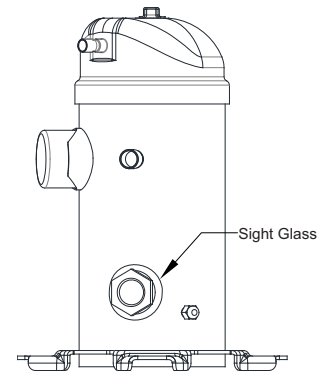

VZH 044/035/028

When the system has been running low on oil at a low RPM, less than 3000 RPM (100 Hz) for 19 minutes, the internal lubrication algorithm in the drive will accelerate the compressor. The compressor will accelerate to 4200 RPM (140 Hz) for 60 seconds. This will make sure there is sufficient lubrication of the compressor's moving parts. When “Hands On” mode is selected, the oil return management will not be active, even if the parameter is set to be on. If the compressor does run below 3000 RPM (100 Hz) for 19 minutes, an error will occur, and the compressor will shut down. For 3-Ton units the minimum/maximum speed for the compressor is 1500 RPM (50 Hz)/4200 RPM (140Hz). For 4-Ton units the minimum/maximum speed for the compressor is 1500 RPM (50 Hz)/4800 RPM (160Hz). For 5-tons and up, the minimum/maximum speed for the compressor is 1500 RPM (50 Hz)/6000 RPM (200Hz).

Oil level sensor – This sensor is an optical sensor that monitors the compressor's internal oil level. The sensor will send a signal to the VFD controller. A warning will be displayed on the HMI if a low oil level condition exists. If the oil level is low, the system will enter a secondary oil boost. If the oil level is still low after this boost cycle, the system will shut down and display a fault.

If the oil level is low, add oil as necessary when the compressor is idle. Use PVE oil from new containers. **DO NOT CONTAMINATE THE OIL.** Connect an oil hand pump to the Schrader valve connection on the compressor. Add oil until the level fills 50-75% of the sight glass after the unit has been off for at least 5 minutes.

Compressor VZH 065

When the system has been running low on oil at a low RPM, less than 2400 RPM (80 Hz) for 19 minutes, the internal lubrication algorithm in the drive will accelerate the compressor. The compressor will accelerate to 3600 RPM (120 Hz) for 60 seconds. This will make sure there is sufficient lubrication of the compressor's moving parts. When “Hands On” mode is selected, the oil return management will not be active, even if the parameter is set to be on. If the compressor does run below 2400 RPM (80 Hz) for 120 minutes, an error will occur, and the compressor will shut down. The minimum/maximum speed for the compressor is 1000 RPM (50Hz)/6600 RPM (330Hz).

If the oil level is low, add oil as necessary when the compressor is idle. Use PVE oil from new containers. **DO NOT CONTAMINATE THE OIL.** Connect an oil hand pump to the Schrader valve connection on the compressor. Add oil until the level fills 50-75% of the sight glass after the unit has been off for at least 5 minutes.

Compressor VZH 088/117/170

When oil return management is enabled, the frequency converter performs an oil boost when the compressor is below 3000 RPM (100 Hz). The oil boost will happen every 60 minutes for 30 seconds when the compressor speed is below 3000 RPM (100 Hz). When “Hands On” mode is selected, the oil return management will not be active, even if the parameter is set to be on. The minimum/maximum speed for the compressor is 1500 RPM (50 Hz)/6000 RPM (200Hz).

Oil boost – This function is controlled by the Variable Frequency Drive converter (VFD-02) to return oil from the system to the compressor when oil balance cannot be reached or maintained in a defined time period.

Oil solenoid – The MUA board controls the oil solenoid (**Figure 34**), which will then actuate the valve. This solenoid valve set up helps optimize the oil circulation and improves efficiency of the compressor at all running speeds. Control parameters are factory preset but are accessible on the parameter list as read-only values.

Oil level sensor – This sensor (**Figure 34**) is an optical sensor that monitors the compressor’s internal oil level. The sensor will send a signal to the VFD controller. A warning will be displayed on the HMI if a low oil level condition exists. If the oil level is low, the system will enter a secondary oil boost. If the oil level is still low after this boost cycle, the system will shut down and display a fault.

If the oil level is low, add oil as necessary when the compressor is idle. Use POE oil from new containers. **DO NOT CONTAMINATE THE OIL.** Connect an oil hand pump to the Schrader valve connection on the compressor. Carefully add oil until the oil level sensor is satisfied after the compressor has been off for at least 5 minutes. Repeat until the oil level sensor is satisfied for at least 30 minutes of unit operation.

Figure 34 - Oil Level Sensor and Solenoid

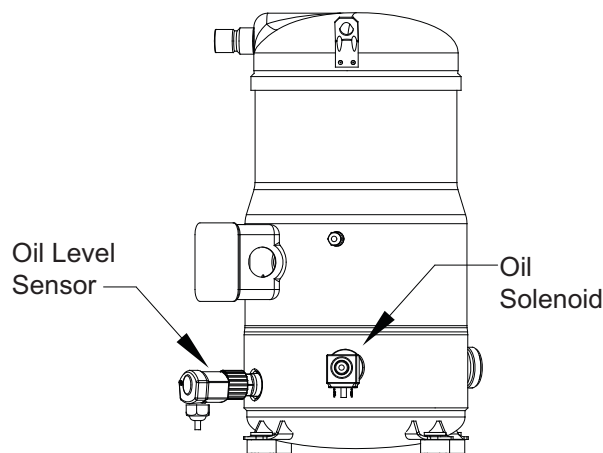

Compressor Drive Information

Refer to **Figure 35** for CDS 803 controller interface. Refer to **Figure 36** for CDS302/303 controller interface.

CDS803 Quick Menu Navigation

The parameter setting for the compressor drive is factory set and should not be adjusted unless specified by a service representative. If replacing the compressor drive, verify the settings match the compressor drive parameter settings. If settings need to be programmed, proceed with the following:

- Press “Menu” to enter the “Quick Menu.”
- Press [▼] to select “Compressor Function.”
- Press “OK” to enter parameter screen.
- Press “OK” to enter and edit the parameter. Use [▲] [▼] to adjust the parameter to the factory settings. Press “OK” to set parameter.
- Use the VFD schematics to locate the parameters that will need to be adjusted.

CDS803 Main Menu Navigation

“Main Menu” is used for access to and programming of all parameters. The Main Menu parameters can be accessed readily by using the password. See VFD schematic for password.

For most Compressor Drive applications, it is not necessary to access the Main Menu parameters, but instead, the Quick Menu provides the simplest and quickest access to the typical required parameters.

The Main Menu accesses all parameters.

- Press [Menu] until indicator in display is placed above “Main Menu.”
- Press [▲] [▼] to browse through the parameter groups.
- Press “OK” to select a parameter group.
- Press [▲] [▼] to browse through the parameters in the specific group.
- Press “OK” to select the parameter.
- Press [▲] [▼] to set/change the parameter value.

Press “Back” to go back one level.

NOTE: Contact Factory Service Department if more information is needed.

CDS803 Reset

1. Power off the drive.
2. Press and hold “OK” and “Menu” buttons.
3. Apply power to the drive while holding the “OK” and “Menu” buttons.
4. Release the buttons after the VFD has been powered for 10 seconds.
5. Reprogram the VFD according to the factory schematics.

Figure 35 - CDS 803 Interface Controller

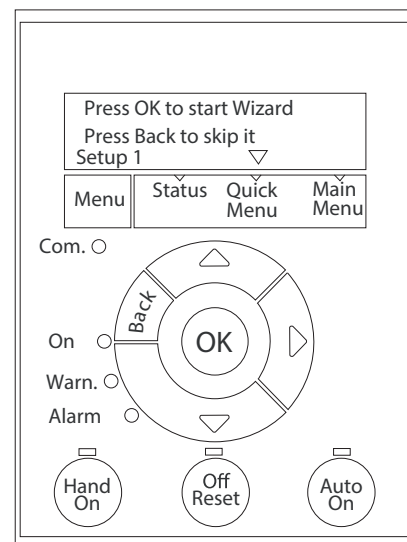

CDS302/303 Quick Menu navigation

The parameter setting for the compressor drive is factory set and should not be adjusted unless specified by a service representative. If replacing the compressor drive, verify the settings match the compressor drive parameter settings. If settings need to be programmed, proceed with the following:

- Press 'Quick Menus.'
- Press the down arrow to select 'Compressor Functions.'
- Press 'OK' to enter the parameter screen.
- Use the arrow keypad to select parameters. Press 'OK' to enter the parameter screen.
- Press 'OK' to enter and edit the parameter. Use the arrows keypad to adjust the parameter to the factory settings. Press 'OK' to set parameter.
- Use the VFD schematics to locate the parameters that will need to be adjusted.

CDS302/303 Main Menu

In the Main menu mode, the parameters are divided into groups. Use the navigation keys for selecting a parameter group.

After selecting a parameter group, select a parameter with the navigation keys. The middle section on the display shows the parameter number and name.

The procedure for changing data is the same in both the Quick menu and the Main menu mode.

Press "OK" to change the selected parameter. The procedure for changing data depends on whether the selected parameter represents a numerical data value or a text value.

Some of the parameters cannot be changed from the LCP. These parameters are defined by the compressor choice made in 1-13 Compressor Selection. The parameters come up as "Read-only."

NOTE: Contact Factory Service Department if more information is needed.

CDS302/303 Reset

1. Power off the drive.
2. Press and hold "Status", "Main Menu" and "OK" buttons.
3. Apply power to the drive while holding the "Status", "Main Menu" and "OK" buttons.
4. Release the buttons after the VFD has been powered for 10 seconds.
5. Reprogram the VFD according to the factory schematics.

Figure 36 - CDS 302/303 Interface Controller

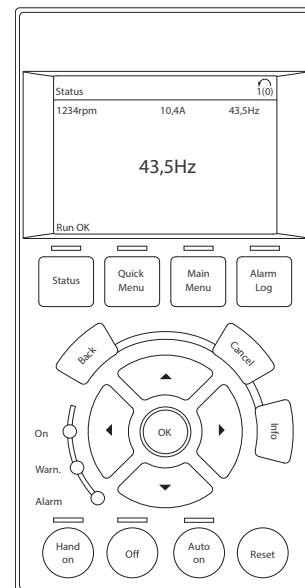

OPERATION

Accessing Menu Configurations

General Overview

The HMI (Human Machine Interface) allows the user to change parameters and options. The user may use the HMI to view operating information regarding sensors, temperatures, pressures, and fault history on the HMI screen (**Figure 37**).

There are four buttons to navigate through the HMI screens.

NOTE: Buttons change functions during certain options and tests. Verify the screen and buttons throughout the menu display.

When the HMI Home Screen (**Figure 39**) is active, the Temp +/- buttons may be used to adjust basic temperature settings. Adjustments made are not permanent, and are based on Occupancy Configuration and Override Duration parameters in Factory Settings.

The user can access the Top Menu HMI configurations by pressing the top two buttons simultaneously. To exit this screen, simply press the 'BACK' button. When setting certain options or functions, pressing the 'BACK' button multiple times will bring up the save screen (**Figure 38**). The user may select 'YES' to save the changes, select 'NO' to return to factory settings, or select 'CANCEL.' When selecting 'CANCEL,' any changes made will not be saved, and the screen will return to the top menu.

The HMI menu system allows full access to every configurable parameter in the HMI. The parameters are factory configured to the specific application. Parameters may need to be modified to fine-tune automatic operation after the original setup.

Remote (HMI) Control Panel

On units shipped with a space HMI, a Cat 5 cable will need to be run from J4, J5, or J6 (refer to schematics) on the main MUA Board to J2 on the HMI. If additional space HMIs have been added, they can be daisy-chained from the first HMI. In the event there is a slave MUA Board, HMIs can also be powered from J1 or J2 of the slave board. An end of line resistor should be added to the last HMI in the chain.

HMI Notification Letters

The HMI will display notification letters (**Figure 39**) when the unit is in a specific status.

- B = Blower Start or Blower Stop Delay Active
- C = Compressor Min On or Min Off Timer Active. Displayed when the unit loses a call for cooling or heating (heat pump) during the compressor's "Min ON" or "Min OFF" time.
- E = Economizer Function
- O = Compressor Oil Boost
- T = Throttle Mode Active
- D = Dehumidification mode. Displayed when in dehumidification.
- Δ = Dynamic SP Applied.

Figure 37 - HMI Screen

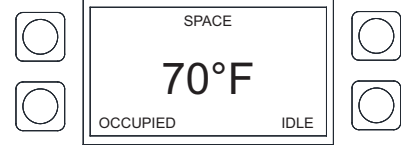

Figure 38 - Save Screen

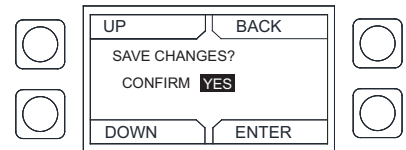
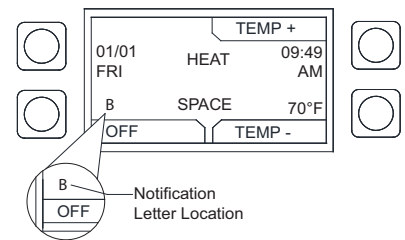

Figure 39 - Notification Letters



HMI Configuration Menu

To enter the configuration menu (**Figure 40**), press the bottom two buttons simultaneously on the HMI faceplate. In this menu screen, you may adjust Communication and Advanced Options, check Status, and About information.

Figure 40 - Configuration Menu

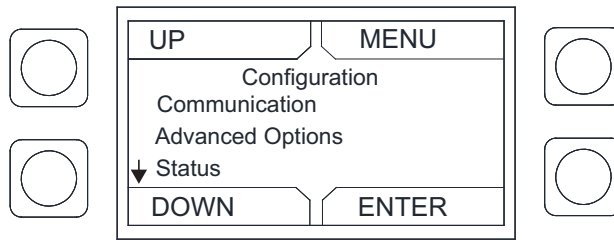

Communication

Under the communication menu, the user may adjust the following settings:

- **Modbus Address** - Default is 55 for the first HMI. For every additional HMI, increase the address by one. For example, if a second HMI is used, the Modbus Address should be 56. For a third HMI, the Modbus Address should be 57.
- **Baud** - The baud rate address is 115200.
- **Parity** - Do not adjust this setting. The default setting should always be set to 'EVEN.'

Advanced Options

Under advanced options, the user may adjust the following settings:

- **Contrast** - The user may adjust the setting from 0 to 10. Setting the contrast to 0 is the lowest setting available, and 10 is the highest contrast setting available. The factory default contrast setting is 5.
- **Audio Enable** - User may set the audio to off.
- **Dimming Enable** - Default is set to Off. If set to On, the 'HMI Dimming Timer' option will be available.
- **Set Time** - The user may adjust dimming setting from 10-60 seconds. The default time is 30 seconds.
- **RH Chip** - Relative Humidity sensor manufacturer. This setting is auto-detected. **DO NOT CHANGE SETTING.**
- **Temp Offset** - Applies a temperature offset to the space HMI reading utilized by MUA Board. Must be set local to each space HMI. Range +/- 20°F. Calibrated individually from the manufacturer. User must consult with manufacturer before making adjustments.
- **RH Offset** - Applies a relative humidity offset to the space HMI reading utilized by MUA Board. Must be set local to each space HMI. Range +/- 30%. Calibrated individually from the manufacturer. User must consult with manufacturer before making adjustments.
- **PS Offset** - Applies a pressure offset to the space HMI reading utilized by MUA Board. Must be set local to each space HMI. Range +/- 200 mb. Calibrated individually from the manufacturer. User must consult with manufacturer before making adjustments.

Status

User may monitor board temperature status, Uptime (how long the board has been active since last restart), HW RH (HMI hardware humidity sensor), HW Temp (HMI hardware temperature sensor).

About

User may view SCADA HMI Software Version, Modbus Address (assigned to HMI), Baud (115200).

Scheduling

To set a schedule on the HMI (**Figure 41**), you must first enable scheduling: **Factory Settings > Occupancy Config > Scheduling > On**

Set your sensor temperature set points for occupied and unoccupied schedules: **User Settings > Temp Set Points > (Varies)**

Once scheduling is enabled and the temperature set points are configured, you may enter your scheduled days and times: **User Settings > Scheduling**

Schedule A Default

- Monday - Friday
8:00AM to 6:00PM
- Saturday and Sunday
Unocc

Schedule B Default

- Monday - Friday
Unocc
- Saturday and Sunday
Unocc

Schedule C Default

- Monday - Friday
Unocc
- Saturday and Sunday
Unocc

Figure 41 - Scheduling Screen

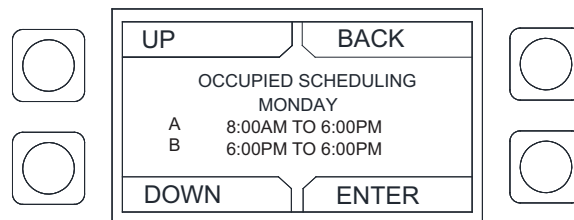

To adjust the settings, highlight the parameter and press **ENTER**.

- The first parameter to be highlighted will be the day. Press **UP** or **DOWN** to select the day an occupied time schedule is required.
- Press **ENTER** to continue to set a start time. Press **UP** or **DOWN** to set start time.
- Press **ENTER** to set an end time. Press **UP** or **DOWN** to set end time.

The system will run between these days, time, and desired temperature settings. When in the UNOCCUPIED setting, the system will run at the unoccupied temperature settings.

Menu Descriptions

USER SETTINGS

Temp Set Points - Some Set Points (SP) may not be available based on settings. If scheduling is enabled, there will be occupied (Occ) and Unoccupied (Unocc) values for each SP. The user will be allowed to check or adjust:

- **Intake Set Points** - User adjustable SP for heat, cool, and dehumidification activation based on intake conditions.
 - **Heat** - Heating will activate if the intake temperature is below this value. "Activate Based On" must be set to Intake, Both, Either, or Stat. Heating Type must be set to a heating configuration.
 - **Cool** - Cooling will activate if the intake temperature is above this value. "Activate Based On" must be set to Intake, Both, Either, or Stat. Cooling Type must be set to a cooling configuration.
- **Discharge Set Points** - User adjustable SP for heat, cool, and dehumidification discharge tempering targets.
 - **Heat** - The unit will target this discharge temperature in heating mode. Tempering mode must be set to discharge or stat. Heating Type must be set to a heating configuration.
 - **Cool** - The unit will target this discharge temperature in cooling mode. Tempering mode must be set to discharge or stat. Cooling Type must be set to a cooling configuration.
- **Space Set Points** - User adjustable SP for heat and cool space activation and tempering.
 - **Heat** - Heating will activate if the space temperature is below this value. The unit will target this space temperature after heating is active. "Activate Based On" must be set to Space, Both, or Either. Heating Type must be set to a heating configuration.
 - **Cool** - Cooling will activate if the space temperature is above this value. The unit will target this space temperature after cooling is active. "Activate Based On" must be set to Space, Both, or Either. Cooling Type must be set to a cooling configuration.
- **Discharge Limits** - Adjustable SP for discharge limits when tempering is active.
 - **Min** - The minimum discharge temperature that the unit can target when heat, cool, or dehumidification is active. Minimum discharge temperature limit cannot be greater than maximum discharge heat/ cool SP.
 - **Max** - The maximum discharge temperature that the unit can target when heat, cool, or dehumidification is active. Maximum discharge temperature limit cannot be less than minimum discharge heat/ cool SP.
- **Differentials** - Adjustable intake/space differential SP.
 - **Intake** - Activate Based On must be set to Intake. Cool tempering mode set to Intake.
 - **Space** - Activate Based On must be set to Space. Cool tempering mode set to Space.

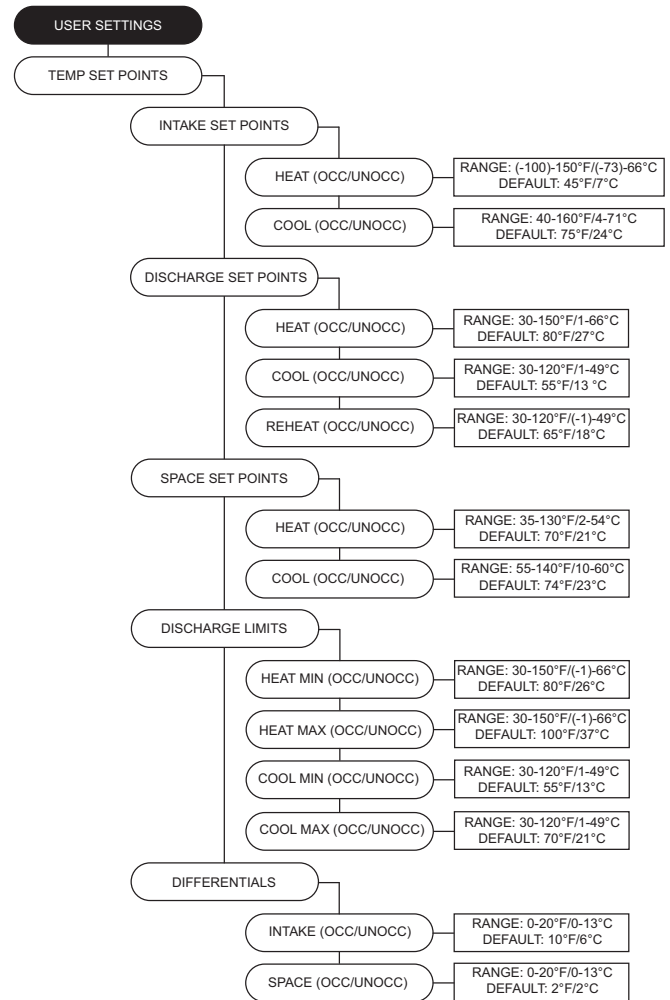

- **Humidity Ctrl** - Adjustable settings dependent on “Reheat Mode” selection.

- **RH Set Points** - Relative Humidity SP

- **Intake** - Dehumidification will activate if the intake RH is above this value. “Activate Based On” must be set to Intake, Both, Either, or Stat. Cooling Type must be set to a cooling configuration.

- **Dschrg** - The unit will target this discharge RH when in dehumidification. Tempering mode must be set to discharge or stat. Cooling Type must be set to a cooling configuration.

- **Space** - Dehumidification will activate if the space RH is above this value. The unit will target this space RH after cooling is active. “Activate Based On” must be set to Space, Both, or Either. Cooling Type must be set to a cooling configuration.

- **DP Set Points** - Dew Point SP

- **Intake** - Dehumidification will activate if the intake DP is above this value. “Activate Based On” must be set to Intake, Both, Either, or Stat. Cooling Type must be set to a cooling configuration.

- **Dschrg** - The unit will target this discharge DP when in dehumidification. Tempering mode must be set to discharge or stat. Cooling Type must be set to a cooling configuration.

- **Space** - Dehumidification will activate if the space DP is above this value. The unit will target this space DP after cooling is active. “Activate Based On” must be set to Space, Both, or Either. Cooling Type must be set to a cooling configuration.

- **Vapor PS Set Points** - Vapor Pressure SP

- **Intake** - Dehumidification will activate if the intake VPD is above this value. “Activate Based On” must be set to Intake, Both, Either, or Stat. Cooling Type must be set to a cooling configuration.

- **Dschrg** - The unit will target this discharge VPD when in dehumidification. Tempering mode must be set to discharge or stat. Cooling Type must be set to a cooling configuration.

- **Space** - Dehumidification will activate if the space VPD is above this value. The unit will target this space VPD after cooling is active. “Activate Based On” must be set to Space, Both, or Either. Cooling Type must be set to a cooling configuration.

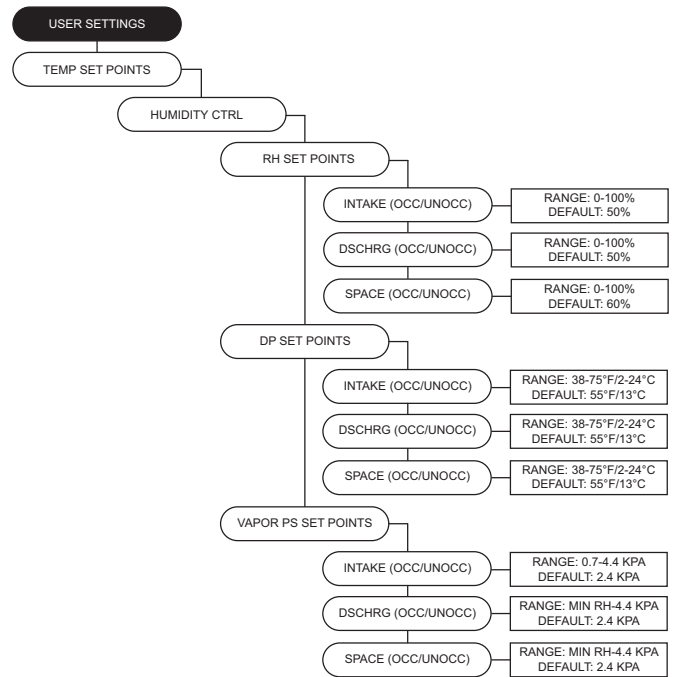

- **Option Set Points** - Adjustable Set Points (SP) for options that are enabled to “ON” in Factory Settings.
 - **Room Override** - The discharge air temperature set-point that the unit will revert to when room override logic is active (see Factory Settings - Room Override for more information).
 - **Firestat Set Points** - Adjustable activations SP.
 - **Intake/Discharge** - If the intake/discharge temperature sensor goes above SP, the unit will shut down. Reset on HMI.
 - **Freezestat Set Point** - Adjustable activation SP. Must be 2 degrees less than Min Heat Discharge.
 - **Intake/Discharge** - If the discharge temp sensor goes below this SP, the unit will shut down. Reset on HMI.
 - **Cabinet Heat** - If equipped, cabinet heater will activate when the RTC temperature drops below SP.
 - **Drain Heat** - If equipped, drain heater will activate if OA temperature is below the SP.
 - **Overheat Set Point** - When in cooling or blower mode, if the discharge temperature exceeds SP, the blower/unit will shut down. Reset on HMI.
 - **Economizer Settings** - Activation SP for economizer (see Factory Settings - Economizer for more information).
 - **Temp Settings**
 - **Temp** - When OA drops below “Temp,” the economizer will activate.
 - **Band** - Damper’s position will be based on “Economizer Temp” SP minus the “Temp Band.” Damper will be fully open when OA temp is below Economizer Temp minus Temp Band.
 - **Total Band Settings** - Setting available when Economizer is set to Fixed Total or Diff Total.
 - **RH** - The damper will modulate when outside air dew point is less than “Temp” and “RH” SP.
 - **Band** - Damper’s position will be based on “Temp” and “RH” SP, minus the “Band.” Damper will be fully open when OA DP is below Economizer DP minus Temp Band DP.
 - **OA Reset Low** - When OA is below reset low SP, discharge heat will target “Reset Heat Discharge.”
 - **OA Reset High** - When OA is above the reset high SP, the discharge cool will target “Reset Cool Discharge.”
 - **Reset Cool Discharge/Space** - Temperature SP for “OA Reset High” functionality.
 - **Reset Heat Discharge/Space** - Temperature SP for “OA Reset Low” functionality.
 - **Comfort Reheat** - Activation SP and timers for comfort reheat logic (see Factory Settings - Comfort Reheat for more information). This menu will only populate if Comfort Reheat is configured.
 - **Temp Diff** - When reheat and “Temp Diff” are met, reheat should activate to meet discharge or space SP.
 - **On Time** - Delay time for comfort reheat activation.
 - **Off Time** - Delay time for comfort reheat deactivation.
 - **Disable Space Sensor** - When enabled On, the unit will temper based on discharge tempering if the space sensor is broken or missing.

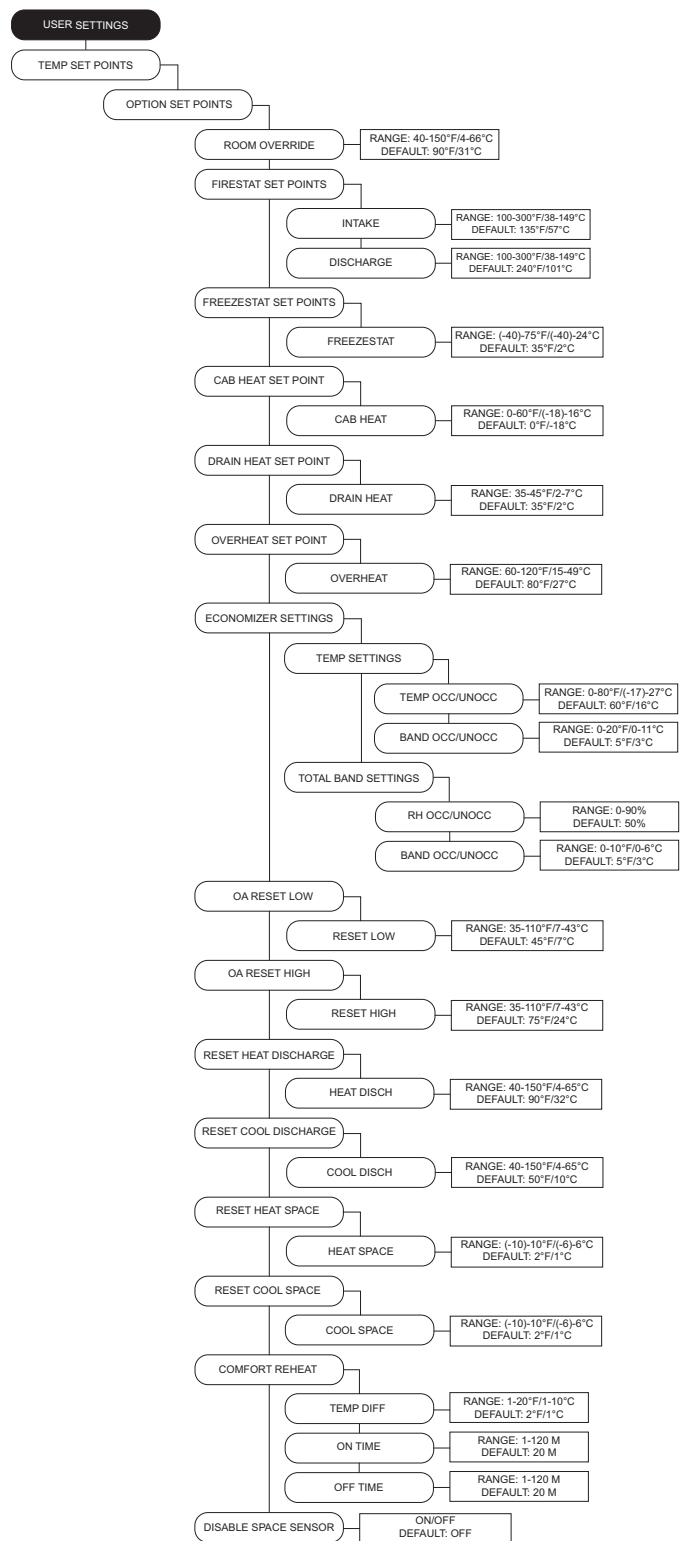

Scheduling - This menu will only show when the scheduling option is set to On.

- **Schedule Times** - Each day contains the option for three occupied time periods. If the time is set past 11:59 pm, it will display 'UNOCC'.
- **Copy Schedule** - This will allow the user to copy an existing schedule from one day of the week to individual days in the week, to Week Days, or All.

Fan Speed - Blower speed setpoint. The range of this menu is limited by the min and max set points under factory settings. When the fan is set to VFD, the settings will be displayed in Hertz. When the fan is set to ECM, the PWM percentage will be displayed. If a VAV blower option is selected the logic may use the min/max speeds in factory settings and this setting may not be available. When occupied scheduling is set to On, occupied and unoccupied settings are available.

Outdoor Air Setting - Enabled when the outdoor air is set to percentage/voltage or scheduled control. Limited by min and max outdoor air percentages/voltages located in **Factory Settings > Unit Options > Outdoor Air Config > Outdoor Air Limits**. If a VAV damper option is selected the logic may use the min/max damper positions in factory settings and this setting may not be available.

Compressor Freq - Menu is active when compressor is set to manual. For diagnostic or testing purposes, use the Test Menu in Service Settings. Verify compressor model (*).

Man Cond Fan Speed - Menu is active when cond fan mode is set to manual. For diagnostic or testing purposes, use the Test Menu in Service Settings

- **Heat** - Enabled when heat pump condensing fan mode is set to manual. Select the % the fans will operate at.
- **Cool** - Enabled when cooling condensing fan mode is set to manual, you may select the % the fans will operate at.

Pressure Config - Static pressure range SP. This menu will only populate if a pressure control option is configured.

- **Blower PS SP** - Adjustable blower pressure SP range.
- **OA PS SP** - Adjustable outdoor air pressure SP range.
- **PE PS SP** - Adjustable powered exhaust pressure SP range.

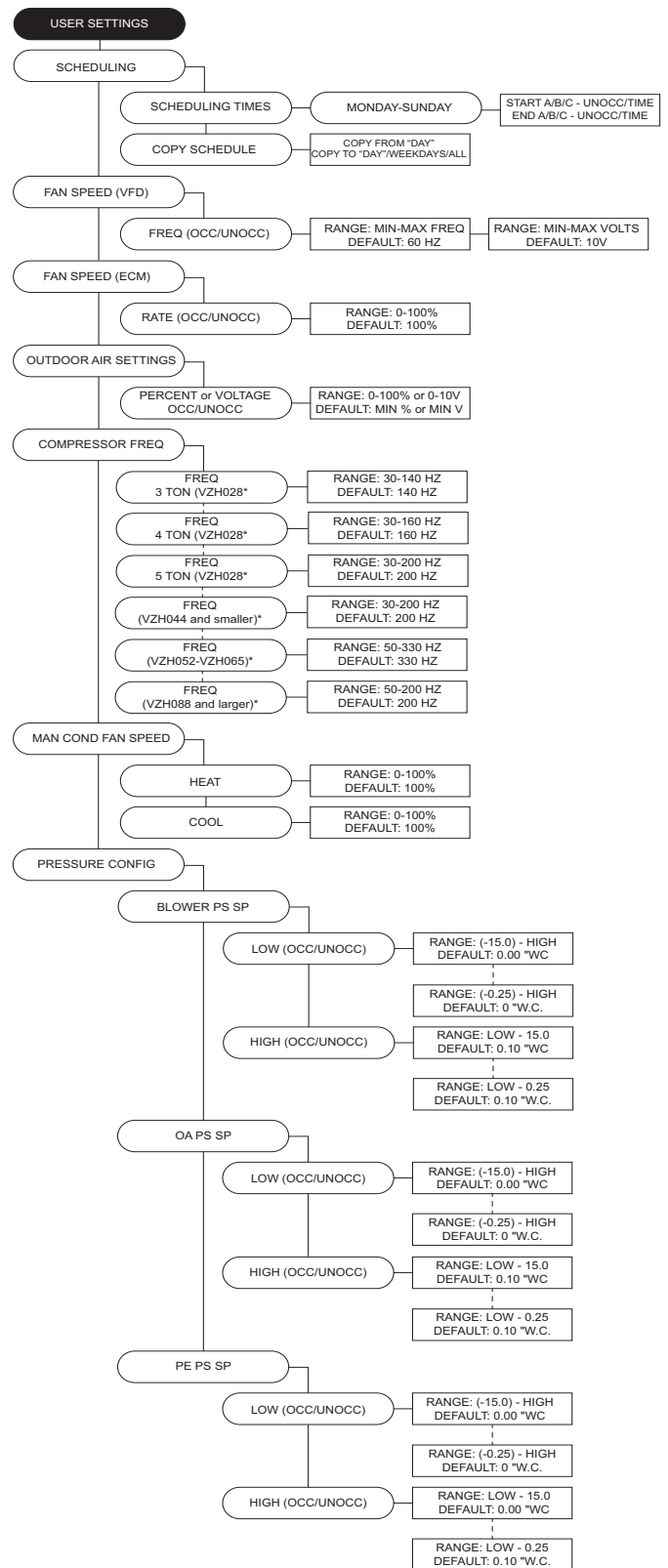

Single Zone VAV - Blower speed and damper position ranges for the single zone VAV logic (see Factory Settings - Single Zone VAV for more information). This menu will only populate if a Single Zone VAV option is configured.

- **Blower Speed Heat** - Min/Max range settings for blower speed in heating mode. Blower to modulate with the discharge temp. When normal logic is set (non-inverted): min discharge = min blower speed; max discharge = max blower speed. Scaled linearly between min/ max discharge to min/max blower speed.
- **Blower Speed Cool** - Min/Max range settings for blower speed in cooling mode. The blower will modulate with the discharge temp. When normal logic is set (non-inverted): min discharge = max blower speed; max discharge = min blower speed. Scaled linearly between min/max discharge to min/max blower speed.
- **Blower Speed Reheat** - Min/Max range settings for blower speed in dehumidification mode. The blower will modulate with the coil temp. When normal logic is set (non-inverted): min coil temp = max blower speed; max coil temp = min blower speed. Scaled linearly between min/max discharge to min/max blower speed.
- **Damper Pos Heat** - Min/Max range settings for damper position in heating mode. Damper to modulate with the discharge temp. When normal logic is set (non-inverted): min discharge = min damper position; max discharge = max damper position. Scaled linearly between min/ max discharge to min/max damper position.
- **Damper Pos Cool** - Min/Max range settings for damper position in cooling mode. The damper will modulate with the discharge temp. When normal logic is set (non-inverted): min discharge = max damper position; max discharge = min damper position. Scaled linearly between min/max discharge to min/max damper position.
- **Damper Speed Reheat** - Min/Max range settings for damper position in dehumidification mode. The damper will modulate with the coil temp. When normal logic is set (non-inverted): min coil temp = max damper position; max coil temp = min damper position. Scaled linearly between min/max discharge to min/max damper position.

Dry Mode Config - SP and limits used in dry mode logic (see Factory Settings - Dry Mode for more information). This menu will only populate if dry mode is configured.

- **Discharge Temp** - User defined discharge activation value.
- **Outdoor Air %** - User defined OA% activation value.
- **Cool SP** - User defined cool SP activation value.
- **Min Temp** - User defined dry mode min temp activation value.
- **Dry Mode Hyst** - User defined dry mode hysteresis activation value.
- **DB Temp Offset** - User defined dry bulb offset activation value.
- **Dew Point Offset** - User defined dew point offset activation value.

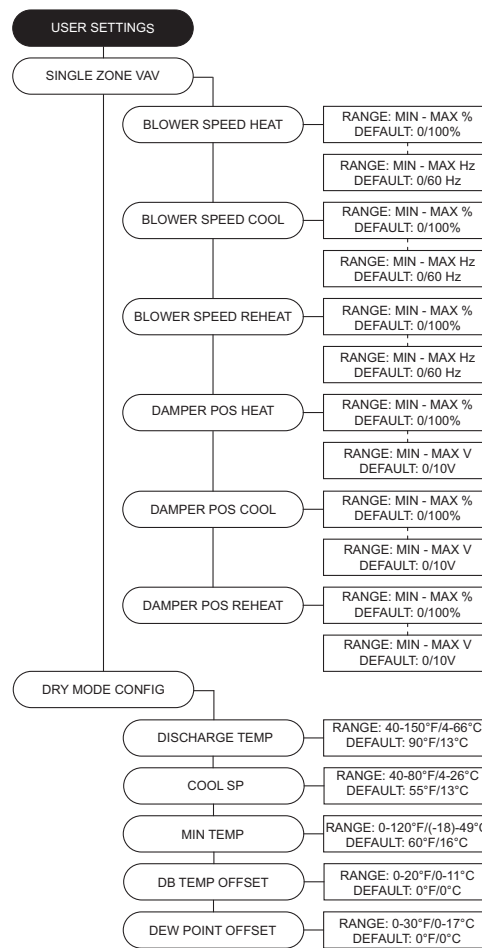

ERV Settings - Energy Recovery Ventilator (ERV) settings. This menu will only populate if ERV is configured.

- **ERV Wheel** - Adjustable ERV wheel speed when ERV wheel control is set to manual. This setting is typically hidden due to ERV wheel modulating automatically based on heating/cooling/dehumidification demand.
- **ERV Exhaust Fan** - Adjustable fan speed when ERV exhaust fan control is set to manual.
- **ERV Wheel Cleaning** - When ERV wheel cleaning is set to manual, this setting is used to activate the cleaning cycle.

Dynamic SP Diff - OA temperature differential required for dynamic SP change (see Factory Settings - Dynamic SP for more information).

Dynamic SP Offset - Amount the SP will change once the dynamic SP diff is met (see Factory Settings - Dynamic SP for more information).

Dynamic Heat OA - The outdoor air temperature at which dynamic SP heating logic activates (see Factory Settings - Dynamic SP for more information).

Dynamic Cool OA - The outdoor air temperature at which dynamic SP cooling logic activates (see Factory Settings - Dynamic SP for more information).

CO2 Control Config - CO2 Parts Per Million (PPM) SP and sensor settings. This menu will only populate if CO2 damper or blower controls are configured.

- **PPM Low/High** - CO2 PPM threshold SP for the space, used in CO2 Override.
- **PPM Limit** - CO2 PPM threshold limit set point.
- **Sensor Min/Max** - Set minimum and maximum range setting for CO2 sensor.

Active Faults - Contains the current faults on the board.

Fault History - Displays time-stamped history of the last 20 faults, most recent fault showing first.

Reset Lockouts - Displayed when a lockout fault has occurred. Enter menu to reset fault(s).

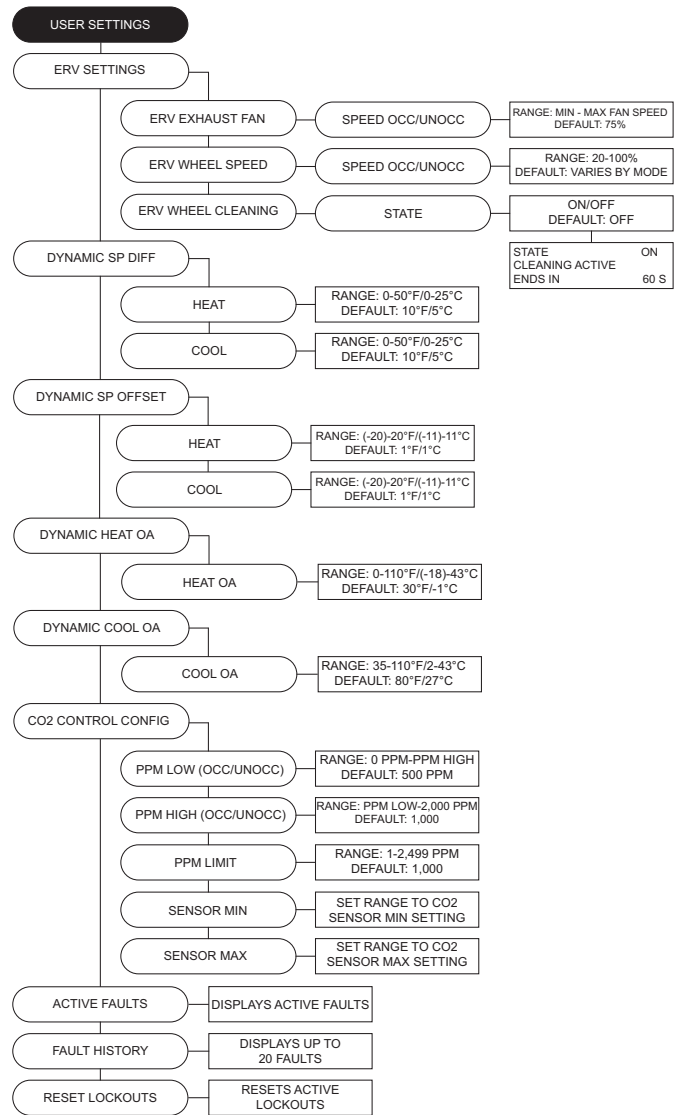

FACTORY SETTINGS - Factory Menu Password = 1111

Temperature Control - The MUA board monitors temperature control components.

- **Tempering Mode** - This setting dictates what conditions or inputs the unit will use to control heating, cooling, and dehumidification after they are active. Options for this setting are Discharge/ Space/Analog/Direct Digital Control (DDC). Refer to “**Sequence of Operation**” on page 95.
- **Activate Based On** - This setting dictates how the unit will activate heating, cooling, or dehumidification. Options for this setting are Intake/Space/Both/Neither/ Stat (field installed thermostat). When set to Stat, the thermostat inputs and intake temperatures are monitored to activate heating/cooling.
- **Construction Mode** - Configurable option for units used being used while the space is actively under construction.

Heating Config - Configurable settings for the heating system.

- **Heating Type** - Select unit's heating type.
- **Heat Hyst**
 - **Space** - The space tempering sensor must go this amount of degrees above the set point before heating turns off.
 - **Intake** - The intake tempering sensor must go this amount of degrees above the set point before heating turns off.
- **2nd Disch Sensor** - When an additional thermistor is added, this feature is enabled to average the primary and secondary discharge air thermistors.
- **Input Source** - When heat tempering mode is set to “Analog”, this setting is used to let the board know what signal (volts or milliamps) will be used to control the heat output.
- **Gas Heat Config**
 - **# of Heat Stages** - Default is set to ‘0’ for units without gas heat. Select ‘1’ for units equipped with gas heat. Select ‘2’ for units equipped with gas heat and high turndown.
- **Relay Delays**
 - **ROT** - This is the time after a furnace loses a call for heat before the furnace shuts down.
 - **RCT** - The Relay Close Time (RCT) is the time after a stage of heat receives a call for heat before the furnace starts up.
- **Powervent Config** - The control signal output type that is used for the gas heat inducer.
- **Furnace Float** - Monitors the water level from condensation in the heater drain line. Enable On if a float switch is installed. Required on high-efficiency furnaces.
- **High Turndown** - Enable On for split burner manifold option.

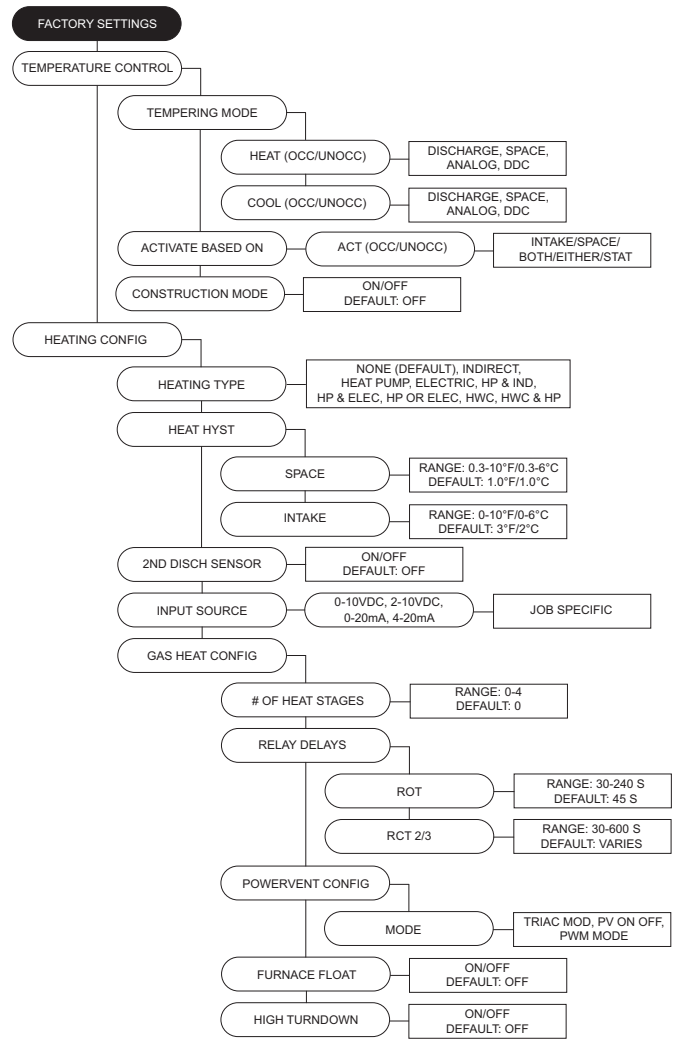

- **Gas Valve Limits**
 - **V1 Min/V2 Min** - Limits min voltage for modulating gas valve.
 - **V1 Max/V2 Max** - Limits max voltage for modulating gas valve.
 - **High Fire** - Limits high fire voltage.
- **Flame Lockout Config** - When enabled On, if the unit's temp rise does not exceed Flame Lockout Temp Rise SP after the duration of the Flame Lockout Timer, a flame lockout will occur.
 - **Temp Rise** - Temp rise limit.
 - **Time** - Amount of time before lockout occurs.
- **Heat Pump Config** - This menu only populates if the heating type is set to one of the options that utilizes heat pump.
 - **Cond Fan Config**
 - **Mode** - Used to select the condensing fan control method.
 - **OA Diff** - When OA Temp Diff is selected for the condensing fan mode, the fans modulate airflow to maintain the discharge saturation temperature at this differential to outdoor air temperature when in a heat pump call.
 - **Min Speed/Max Speed** - The minimum and maximum rate the condensing fans will operate.
 - **Pre-Defrost Config** - Option to energize a refrigerant solenoid to thaw the outdoor coil in a heat pump call before a defrost or backup heating cycle is started. This feature will only populate if extreme low ambient heat pump pre-defrost solenoid is installed and extreme low ambient heat pump is configured.
 - **Cycles** - Number of pre-defrost solenoid cycles before defrost mode is allowed to activate.
 - **Cycle Time** - Amount of time the pre-defrost solenoid is open during a cycle.
 - **Window** - Amount of time before the pre-defrost counter is reset.
 - **Defrost Config**
 - **Mode** - This allows for the unit to defrost the outdoor coil in the case of freezing coil conditions in a heat pump call. User may set defrost method to Off/Timer/PressTemp.
 - **Time Off** - If the timer option is selected, the time off default is 15 minutes.
 - **Time On** - Minutes between defrost cycles if in timer or PressTemp mode.
 - **Min Suc PS** - The minimum suction pressure limit to activate a defrost. This setting will only populate if Defrost Mode is set to PressTemp.
 - **Min Suc Temp** - The minimum suction line temperature to activate a defrost. This setting will only populate if Defrost Mode is set to PressTemp.
 - **Comp Min/Comp Max Freq** - Limits the run speed of the compressor.

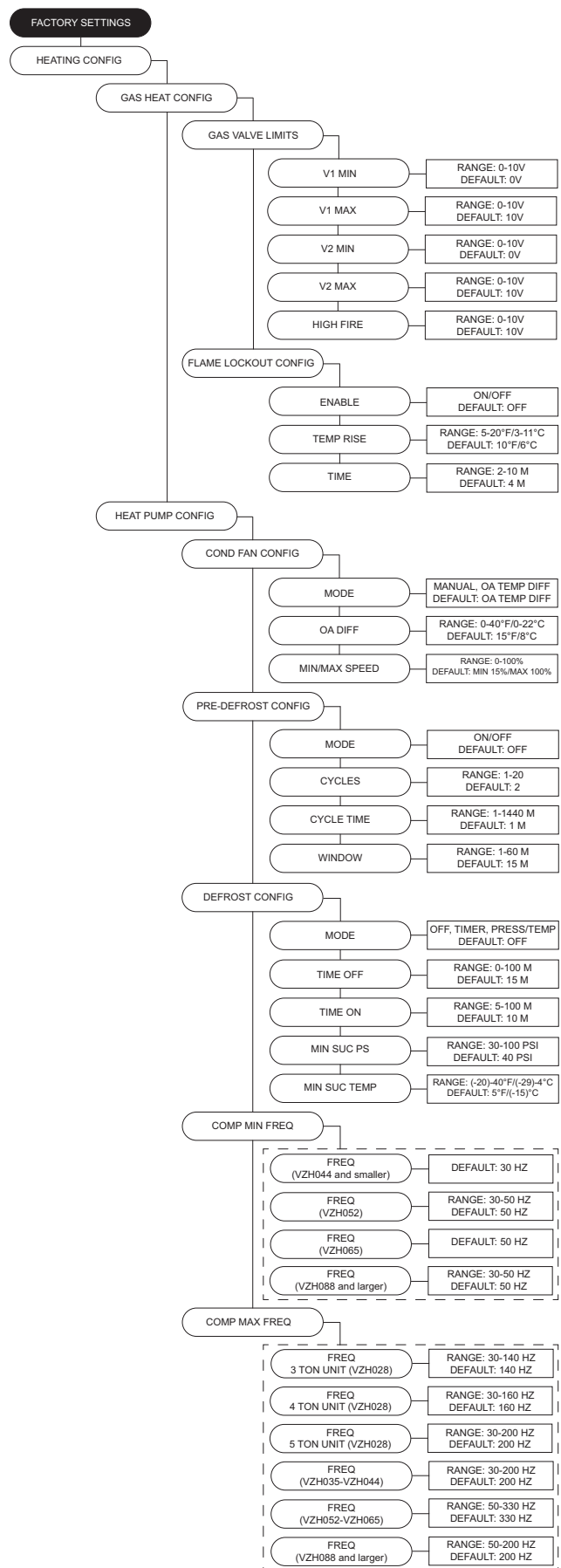

• HP Set Points

- **Min OA Temp** - The heat pump will shut off when the OA temp drops below this SP.
- **Max OA Temp** - The heat pump will shut off when the OA temp rises above this SP.
- **Max IN Temp** - The heat pump will shut off when the IA temp rises above this SP.
- **Superheat** - Target superheat setpoint that the EEV tries to maintain in heat pump mode. Superheat is used to determine the state the refrigerant is in as it leaves the evaporator coil.
- **High Ambient** - Option optimizes heat pump operation when outside temperatures increase to avoid high head pressures from the compressor.
- **Low Ambient Heating** - When enabled, adjustable parameters and logic to improve low ambient heat pump (LA HP) performance down to 0°F ambient.
 - **Act Temp** - LA HP logic will activate when OA temp is below SP.
 - **EEV Pos** - Sets min position for EEV during LA HP start-up for the duration of the EEV control timer.
 - **EEV Control** - Minimum duration setting for EEV position at LA HP start-up.
 - **Thrttl Delay** - Prevents the compressor from throttling on low pressure for the duration of this timer during LA HP start-up.
 - **Cond Min/Cond Max** - The minimum and maximum rate the condensing fans will operate during LA HP operation.
 - **PS Delay** - Low pressure faults are delayed for the duration of this timer during LA HP start-up.
 - **Crankcase** - When enabled on, and LA HP logic is active, the crankcase heater will operate while the compressor is operating.
- **Extreme Low Ambient** - When enabled, adjustable parameters and logic to improve heat pump performance down to -10°F ambient. Extreme low ambient heat pump (ELA HP) solenoid must be present to enable this feature.
 - **Act Temp** - Extreme low ambient heat pump (ELA HP) logic will activate when OA temp is below SP.
 - **EEV Pos** - Sets min position for EEV during ELA HP start-up for the duration of the EEV control timer.
 - **EEV Control** - Minimum duration setting for EEV position at ELA HP start-up.
 - **Thrttl Delay** - Prevents the compressor from throttling on low pressure for the duration of this timer during ELA HP start-up.
 - **Sol Active** - A timer for the bypass solenoid to boost suction pressure on ELA HP start-up.
 - **Sol Delay** - A delay timer before bypass solenoid opens after ELA HP start-up.
 - **Cond Min/Cond Max** - The minimum and maximum rate the condensing fans will operate during ELA HP operation.
 - **PS Delay** - Low pressure faults are delayed for the duration of this timer during ELA HP start-up.

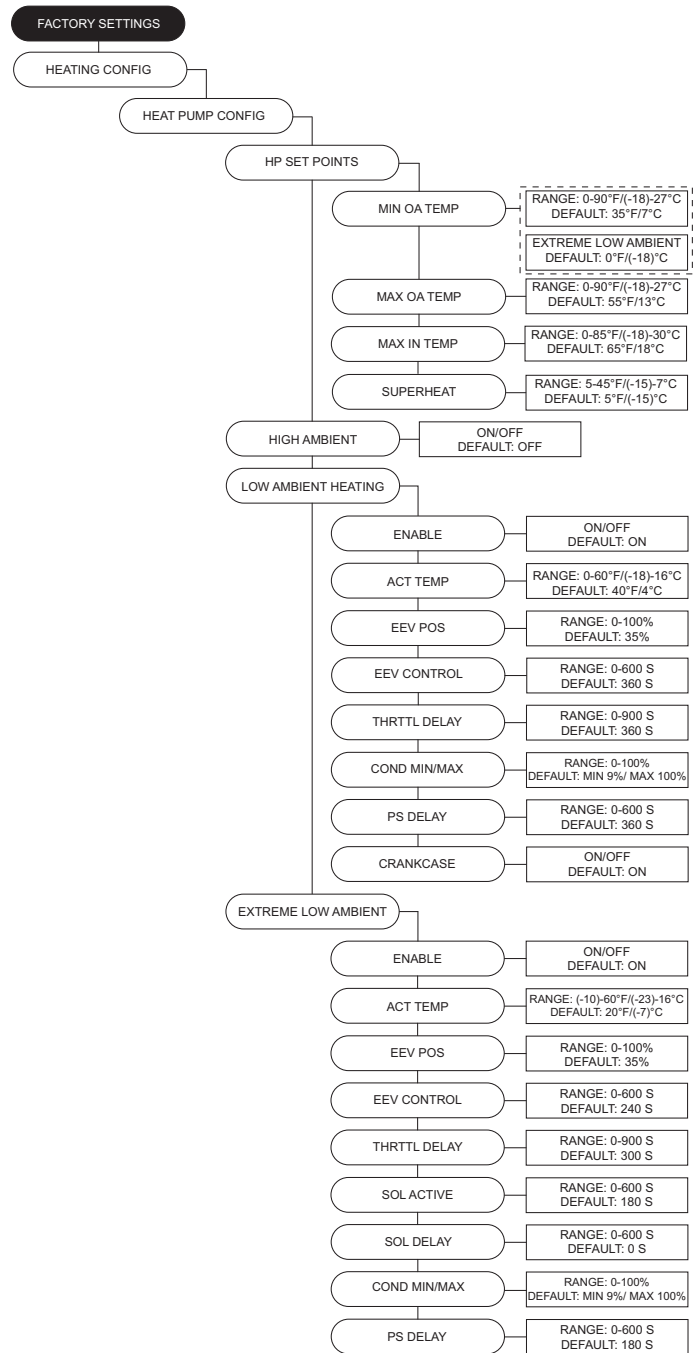

- **Superht SP** - Start-up target superheat during ELA HP start-up.
- **Superht Time** - The timer for the modified superheat target during ELA HP start-up
- **Crankcase** - When enabled on, and ELA HP is active, the crankcase heater will operate when the compressor is on.
- **Sol Throttle** - When enabled, the ELA HP solenoid will open when the compressor is throttling speed.
- **Sol Thr1 Ps** - The suction pressure where the ELA HP solenoid closes after opening for throttling.

• **Electric Heat Config** - This menu only populates if the heating type is set to one of the options that utilizes an electric heat insert.

- **Volts Min** - Limits min voltage for electric inserts.
- **Volts Max** - Limits max voltage for electric inserts.
- **High Disch** - Enabled On, the max discharge limit is 150°F. Enabled Off, the max discharge limit is 90°F.

• **Cabinet Hyst** - The outdoor air temp must reach this many degrees above the activation set point for the cabinet heater to turn off.

• **Freezestat Timer** - The discharge temp must stay below the freezestat set point for this amount of time before the unit will lock-out on freeze stat.

• **Dehumid In Heat** - When enabled On, dehumidification can activate during heating. Menu will only populate if the reheat mode is not set to an option with RH in the name.

• **Max Temp Rise Limit** - Limits maximum temp rise of the configured heating system.

• **HTL Blower Off** - The blower will shut off when the high temperature limit trips.

• **Min/Max Heating** - When enabled On, high fire and low fire test heating settings are adjustable.

Cooling Config - Cooling configuration settings.

• **Cooling Type** - Select unit's cooling type.

• **Cool Stage Time** - Timer for cooling stages.

- **On** - Timer for cooling stage to run.
- **Off** - Timer for cooling stage to turn off.

• **Min Cool (OA) Temp** - The compressor will not activate when outdoor air temperature is below this set point.

• **Min Cool Intake Temp** - The compressor will not activate when intake temperature is below this set point.

• **Cond Fan Config**

- **Mode** - Used to select the condensing fan control method.
- **OA Diff** - When OA Temp Diff is selected for the condensing fan mode, the fans modulate airflow to maintain the discharge saturation temperature at this differential to outdoor air temperature when in a heat pump call.
- **Min Speed/Max Speed** - The minimum and maximum rate the condensing fans will operate.

• **Comp Min/Comp Max Freq** - Limits the run speed of the compressor.

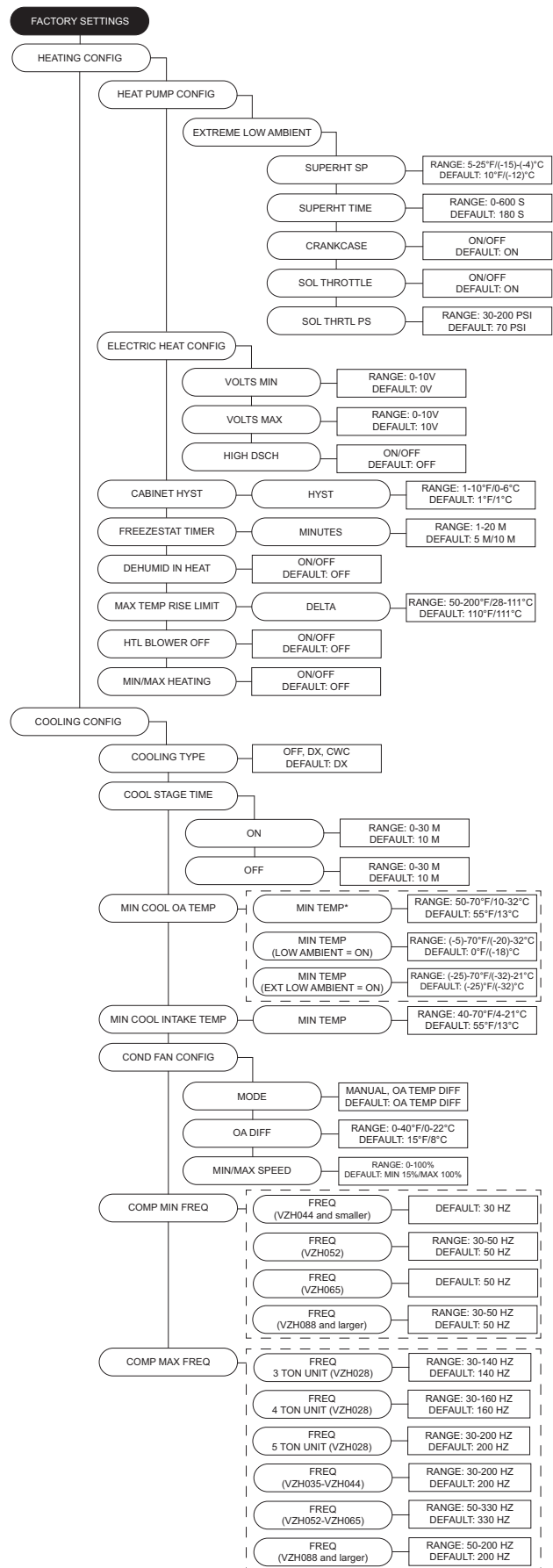

• **Cool Hyst**

- **Intake** - The intake tempering sensor must be this amount of degrees below the set point before cooling turns off.
- **Space** - The space tempering sensor must be this amount of degrees below the set point before cooling turns off.

• **Reheat Config**

- **Reheat Mode** - RH&DP, DP, RH, VP, VP&RH, Off selection. When RH/DP is selected, software will monitor both dew point and relative humidity for reheat activation. When only DP is selected, software will monitor dew point for reheat activation. When only RH is selected, software will monitor relative humidity for reheat activation. When only VP is selected, software will monitor vapor pressure for reheat activation. When VP&RH is selected, software will monitor both vapor pressure and relative humidity for reheat activation. When Off is selected, reheat will not be active.
- **Valve Limits** - Min and max settings for reheat valve position.
- **Valve Output** - The output signal type for the reheat valve.
- **RH/DP Input Mode** - When reheat mode is set to RH/DP, the user may select between DP or RH.

• **Differentials**

- **Space** - Reheat will activate if the cooling mode is set to SPACE, the inside coil temperature and the desired reheat set point is less than the intake dew point minus the space differential.
- **Discharge** - Reheat will activate if the cooling mode is set to "Discharge", the inside coil temperature and the desired reheat set point is less than the intake dew point minus the discharge differential.

• **RH Hyst**

- **Intake** - The Intake RH/DP must go below the intake RH/DP set point plus intake reheat hyst before reheat turns off.
- **Space** - The space RH/DP must go below the intake RH/DP set point plus intake reheat hyst before reheat turns off.

- **Dew Point Adjust** - Settings for dew point adjust. This value determines what dew point the unit will cool to before reheating occurs. If the reheat dew point adjust is set to 5°F, and the reheat set points' dew point is set to 50°F, the unit will cool the air to 45°F before reheating when in a dehumidification call.

- **Dew Point Delta** - If the cooling mode is set to SPACE, reheat can activate if the intake DP is greater than the space DP SP minus the DP Delta. If the cooling mode is set to DISCHARGE, reheat can activate if the intake DP is greater than the discharge DP SP minus the DP Delta.

- **Low Load** - Enabled On, if the unit is only dehumidifying and heating shuts cooling down, the unit should not try to dehumidify again until there is a call for cooling from temp activation. Enabled Off, if the unit is only dehumidifying and heating shuts cooling down, the unit can try to dehumidify again.

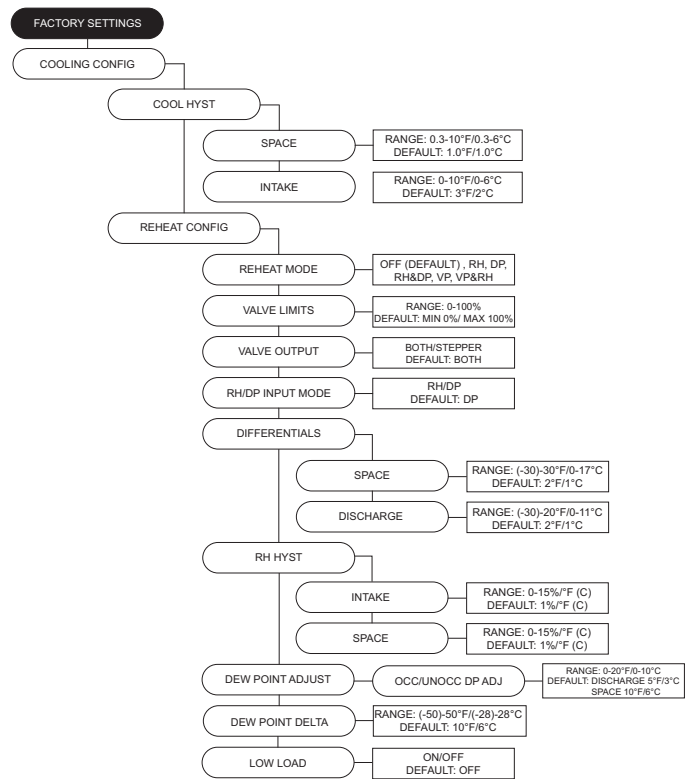

- **Reheat Valve Model** - Valve model selection.
- **Reheat Optimization** - Enabled On, the user may adjust optimization On/Off Timers.
 - **On Time** - Increase condensing fan differential when reheat PID is at 100% for On Time setting and outdoor temp is below 76°F.
 - **Off Time** - Decrease condensing fan differential when reheat PID is at 0% for Off Time setting and outdoor temp is above 77°F.
- **Aux Reheat** - Activates auxiliary heat source (gas or electric) when the unit needs more reheat capacity. Timers will control the staging of the auxiliary reheat source.
 - **On Time** - The time hot gas reheat (HGRH) PID needs to be at 100% before it is shut off and aux reheat is utilized instead. If dual reheat is enabled, this is the time that HGRH reheat PID needs to be at 100% before it is locked at 100% and the aux reheat source is utilized in addition to HGRH.
 - **Off Time** - The time aux reheat PID needs to be at 0% before aux reheat can turn off. If dual reheat is enabled, this is the time that aux reheat PID needs to be at 0% before it is locked in the lowest capacity heat and HGRH is unlocked from 100% and starts to modulate.
- **Stage Time** - Only used for Dual Reheat. The time both aux reheat and HGR PIDs need to be at 0% before turning off the aux reheat source and restarting normal HGRH operation.
- **Dual Reheat** - Allows hot gas reheat and auxiliary heat to operate at the same time.
- **2nd Evap Sensor** - When active, the evap temperature will be averaged between the two sensors.
- **Dynamic DP**
 - **Dynamic DP Config** - When enabled On, adjusts target evaporator temperature based on demand instead of discharging a fixed DP. Only applicable for space tempering
 - **Min Adj/Max Adj** - Minimum and maximum DP adjustment range. If the min adj is set to 5°F and the max adj is set to 10F, and the reheat set points' dew point is set to 50°F, the unit will be able to target a coil temperature in the range of 40F to 45F before reheating when in a dehumidification call.
- **Cool Override Config** - When enabled On, if the unit senses a high sensible heat ratio and the space overheats in a dehumidification call, cooling will override dehumidification.
 - **Min Disch** - Timer before the unit will go to cool override functionality.
 - **Space DP Adj** - Fixed space dew point adjustment that the unit reverts to when cool override is active.
 - **Disch DP Adj** - Fixed discharge dew point adjustment that the unit reverts to when cool override is active.

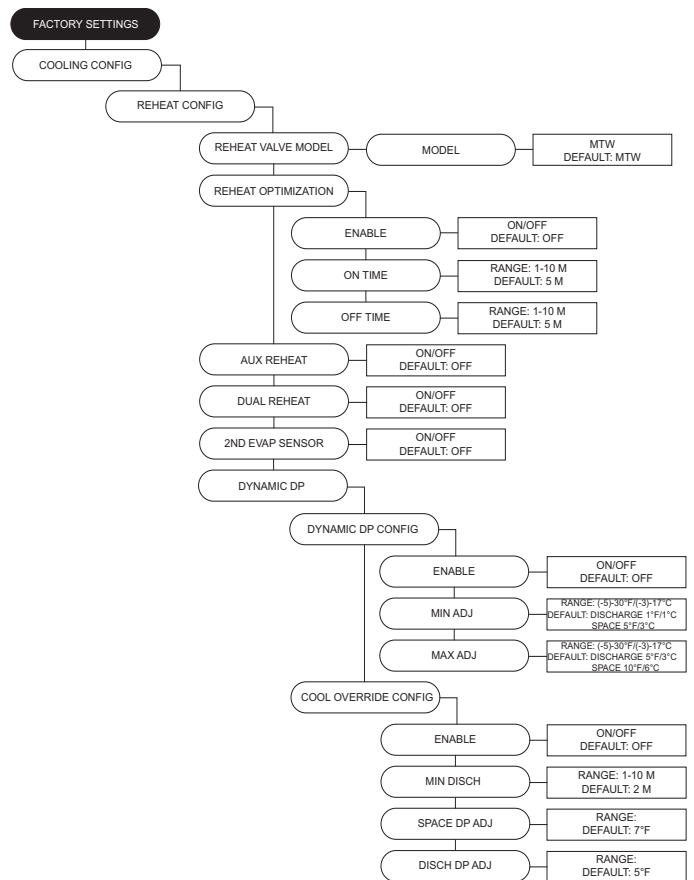

- **Reheat Oil Boost** - When an oil boost is active, the reheat valve will move to this set position.
- **Comfort Reheat** - When enabled, the reheat valve can be used/opened in a standard cooling call to achieve target discharge conditions. To activate, system must be in cooling (not dehumidification) at low compressor speed and system cannot achieve the Cool Discharge Stp – Comfort Reheat Temp Diff (discharge tempering) or the Max Cool Discharge – Comfort Reheat Temp Diff (space tempering).
- **Min PID Override** - In a cooling call when condenser fans are off, lock out hot gas reheat.
- **Superheat Set Point** - Monitors what state the refrigerant is in as it leaves the evaporator coil.
- **Overheat Timer** - The discharge temperature must not exceed the set point for 30 minutes (default), or the unit will shut down. When in cooling or blower only, the unit will wait for the “Comp Min Off Time” for the compressor, then re-attempt to cool again. If the overheat stat fails again, everything will shut down and display the fault “Overheat Stat Failure.”
- **Low Ambient Cooling** - When enabled, adjustable parameters and logic to improve low ambient cooling/dehumidification (LA) performance down to 0°F ambient.
 - **Act Temp** - Low ambient logic will activate when OA temp is below SP.
 - **EEV Pos** - Sets min position for EEV during LA start-up for the duration of the EEV control timer.
 - **EEV Control** - Minimum duration setting for EEV position at LA start-up.
 - **Thrttl Delay** - Prevents the compressor from throttling on low pressure for the duration of this timer during LA start-up
 - **Cond Min/Max** - The minimum and maximum rate the condensing fans will operate at low ambient conditions.
 - **PS Delay** - Low pressure faults are delayed for the duration of this timer during LA start-up.
 - **Crankcase 1/2/3** - Option for crankcase heater to turn on when the compressor is running. Crankcase heater 1 active connector J10-4 on MUA board. Crankcase heater 2 active connector J9-18 on Advanced Cool Board (ACB). Crankcase heater 3 active connector J10-18 on ACB.
- **Extreme Low Ambient** - When enabled, adjustable parameters and logic to improve cooling/dehumidification performance down to -20°F ambient. Extreme low ambient (ELA) solenoid must be present to enable this feature.
 - **Act Temp** - Extreme low ambient (ELA) logic will activate when OA temp is below SP.
 - **EEV Pos** - Sets min position for EEV during ELA start-up for the duration of the EEV control timer.
 - **EEV Control** - Minimum duration setting for EEV position at ELA start-up.
 - **Thrttl Delay** - Prevents the compressor from throttling on low pressure for the duration of this timer during ELA start-up.

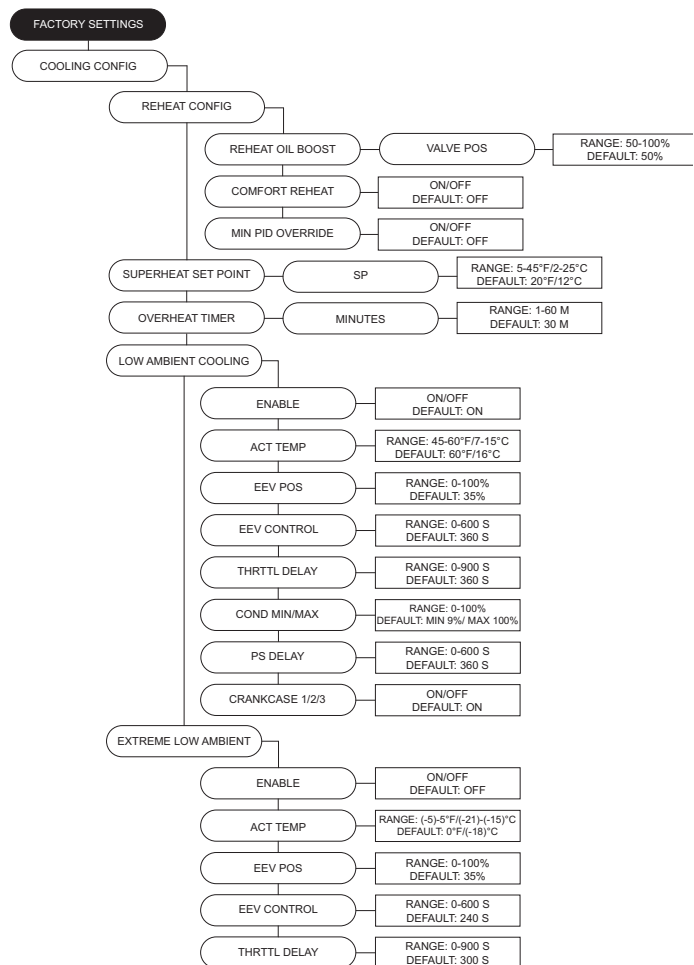

- **Sol Active** - A timer for the bypass solenoid to boost suction pressure on ELA start-up.
- **Sol Delay** - A delay timer before bypass solenoid opens after ELA start-up.
- **Cond Min/Max** - The minimum and maximum rate the condensing fans will operate during ELA operation.
- **PS Delay** - Low pressure faults are delayed for the duration of this timer during ELA start-up.
- **Superht SP** - Start-up target superheat during ELA start-up.
- **Superht Time** - The timer for the modified superheat target during ELA start-up
- **Crankcase 1/2/3** - Option for crankcase heater to turn on when the compressor is running. Crankcase heater 1 active connector J10-4 on MUA board. Crankcase heater 2 active connector J9-18 on Advanced Cool Board (ACB). Crankcase heater 3 active connector J10-18 on ACB.

- **Supply Duct Adj** - Discharge temperature offset is used to ensure there is no condensation on uninsulated supply duct(s).
 - **Adjust** - The minimum offset the discharge temperature will be above space dew point.

Compressor Config - Adjustments for compressor settings.

- **Compressor Drive** - Setting for compressor manufacturer.
- **Circuit Config** - Settings for compressor circuits.
 - **Circuit 1/2/3** - On/Off setting for available circuits.
 - **Order** - Setting for circuit staging operation. Forward = 1, 2, 3. Reverse = 3, 2, 1.
- **Compressor Model** - Compressor model selection.
- **Control Mode** - Allows the user to turn the compressor between manual or auto control.
- **VFD Frequency** - Scaling adjustment for the compressor and compressor drive.
 - **C1/C2/C3 Min** - Defines the minimum speed range of the compressor for cooling/dehumidification mode. Must be set equal to the compressor VFD minimum speed.
 - **C1/C2/C3 Max** - Defines the maximum speed range of the compressor for cooling/dehumidification mode. Must be set equal to the compressor VFD maximum speed.
- **Max Discharge Temp** - Limits discharge temperature out of the compressor.
- **Comp Min Times**
 - **Min On** - Minimum amount of time the compressor stays on.
 - **Min Off** - Minimum amount of time the compressor stays off after being active.
- **Oil Sensor** - Settings for oil sensor circuits.
- **Stage 1/2/3**: Enable/disable the oil sensor monitoring. This feature must be enabled if an oil sensor is present.
- **Oil Boost Time** - Timed compressor boost time option.

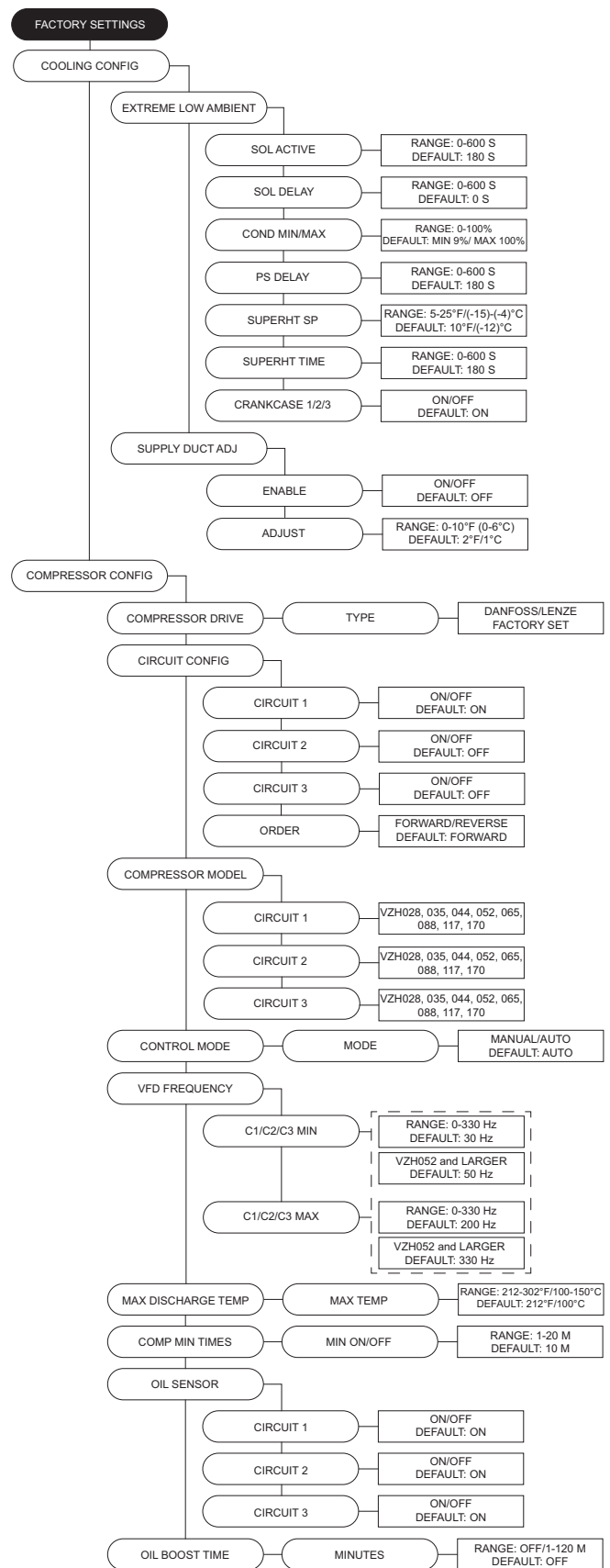

- **Pumpdown Sequence** - Compressor soft stop and liquid migration protection to store most of the refrigerant in the outdoor coil during an off cycle. Before the pumpdown sequence begins, an oil boost will run to return oil back to the compressor before shutting down.
- **Max OP Suction PS** - When suction pressure is above setting, the EEV will close to 0% to drop suction pressure within the envelope range.
- **Low Oil Fault Lock** - If oil is repeatedly lost but regained, the system will lock out. Clear the lockout on the HMI.
- **Refrigerant** - Select the type of refrigerant used in the system.
- **Overheat Protection** - When enabled, protects VFD heat sink from locking out unit.
 - **Max Temp** - When the VFD heat sink rises above set point, cooling will start.
 - **Hyst** - Temperature hysteresis value the unit will stop cooling.
- **Envelope Fault Reset** - Allows one automatic retry when an envelope fault occurs.

EEV Config - Allows user to set Electronic Expansion Valve (EEV) model and adjust EEV position values.

- **Circuit 1/2/3** - Selectable range of EEV models.
- **Min Value** - Adjustable minimum position between 0% to max setpoint.
- **Max Value** - Adjustable maximum position between min set point and 100%.
- **Low SH Enabled** - Enable/Disable for a feature to limit the EEV min position during start-up when low ambient logic is not active
- **Low SH Position** - Minimum EEV position setting for Low SH feature Will show up if Low SH is enabled.
- **Low SH Time** - Minimum EEV position timer for Low SH feature. Will show up if Low SH is enabled.

ERV Config - If the Energy Recovery Ventilator (ERV) option is enabled, ERV settings and parameters will be visible.

- **Energy Recovery** - On/Off selection. If the energy recovery option is set to ON, menus will be available to adjust various energy recovery settings.
- **Recovery Act Control** - Selectable control type and dead band for ERV operation.
 - **Heat Act** - Heating activation method for ERV. Determines if the unit will use sensible, enthalpy or both for ERV tempering activation.
 - **Cool Act** - Cooling activation method for ERV. Determines if the unit will use sensible, enthalpy or both for ERV tempering activation.
 - **Deadband (Sensible)** - A temperature deadband that must be satisfied in order for ERV tempering to activate.
 - **Deadband (Enthalpy)** - An enthalpy deadband that must be satisfied in order for ERV tempering to activate.
- **Wheel Model** - Setting to determine the ERV wheel size. This must be correct for the wheel speed to modulate correctly.
- **Wheel Control** - Auto or manual control settings.

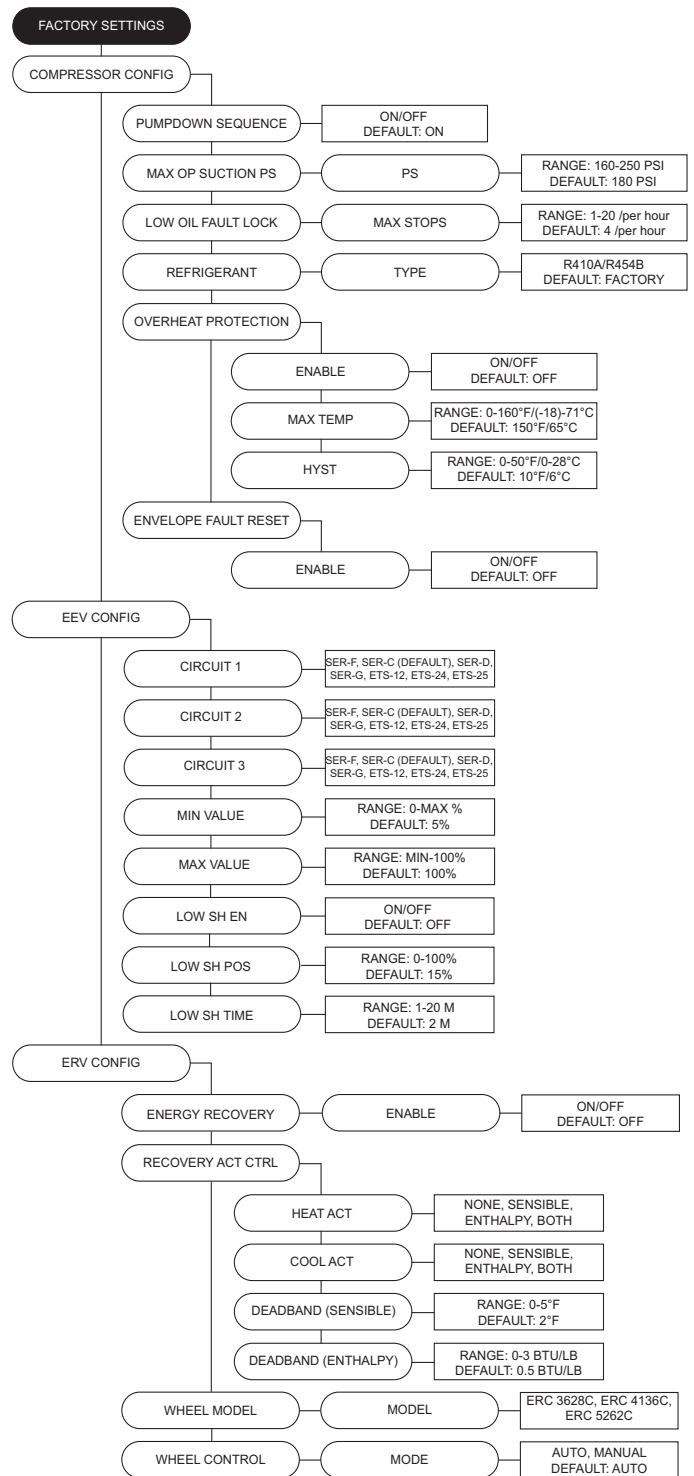

- **Monitoring Sensors** - Values that are associated with the operation of the ERV. Sensor pressure values monitor how much dirt and debris are collected on the filters and wheel.
- **Door Interlock** - When enabled, a “Door Interlock” fault will display when the blower door is open during normal operation. This is only enabled if the door interlock is wired to the control board.
- **Clog Filter** - Setpoint adjustment for ERV filter monitoring. A fault will display when differential pressure is out of range.
- **Frst Wheel** - Setpoint adjustment for frosted wheel monitoring. A fault will display when differential pressure is out of range.
- **Exh Air PS** - Setpoint adjustment for airflow proving. A fault will display when differential pressure is out of range.
- **OA FR Base** - Calibration value for clogged filter and wheel functionality.
- **EA FR Base** - Calibration value for clogged filter and wheel functionality.
- **OA WD Base** - Calibration value for clogged filter and wheel functionality.
- **EA WD Base** - Calibration value for clogged filter and wheel functionality.
- **Miss Fltr Dmp** - Outdoor air damper opening value. A fault will display when damper is out of range.
- **Sup MS Flt SP** - Supply missing filter setpoint.
- **Miss Fltr Spd** - Missing filter pressure setpoint. A fault will display when differential pressure is less than set value.
- **Exhaust Fan Config** - ERV exhaust blower settings.
 - **Control** - Selectable control type for exhaust blower.
 - **Staging** - Selectable activation modes for exhaust blower. Only available with certain modes.
 - **Min Speed Occ/Unocc** - Adjustable range between 0% to Max Speed set point. When occupied setting are enabled, two set points will be available.
 - **Max Speed Occ/Unocc** - Adjustable range between Min Speed set point to 100%. When occupied setting are enabled, two set points will be available.
 - **Purge Speed** - Fixed speed that the exhaust fan will operate when purge is activated.
 - **Low PS Lim** - Low pressure limit setting for building differential pressure.
 - **High PS Lim** - High pressure limit setting for building differential pressure.
 - **Cycle Time** - Cycle time is the time between two consecutive readings.
 - **PS KP** - Proportionally constant value for static pressure measured in V/sec.
 - **PS Hyst** - Building pressure must go above or below hysteresis value for fan adjust accordingly.
 - **S REF KP** - Proportionally constant value for supply fan pressure measured in V/sec. Only displayed when Exhaust Fan Control is set to supply reference.

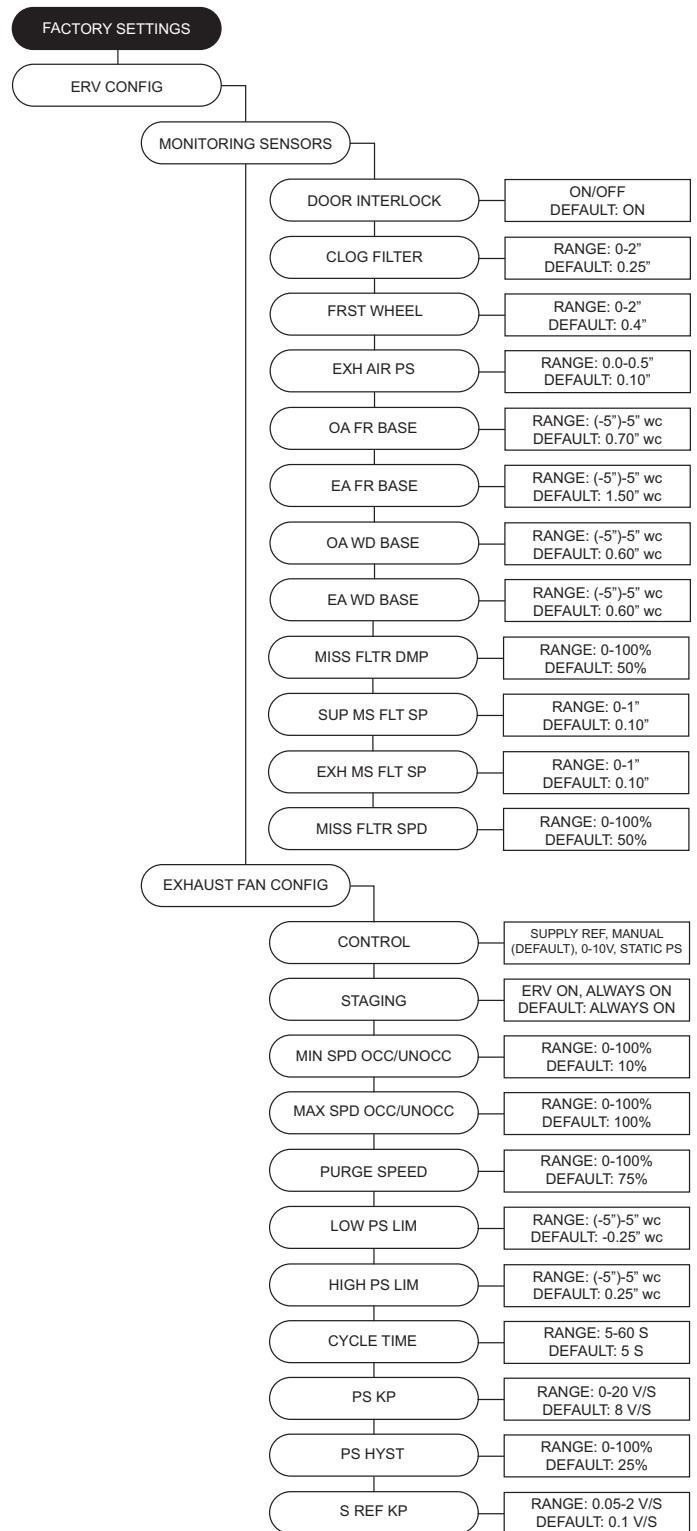

- **S REF DB** - Defines the limits the unit will adjust to keep supply fan reference. Only displayed when Exhaust Fan Control is set to supply reference.
- **S REF SP** - If the pressure difference between the supply and exhaust is greater/less than this set point, the MUA board will attempt to adjust the output voltage until it matches the supply reference set point.
- **EF Comm** - ERV communication loss, dictates functionality of exhaust fan when communication is lost between exhaust fan and ERV.
- **Wheel Size** - Direct drive wheel size selection. The wheel size selection will be utilized for CFM monitoring. Dual blower models will have a '2' assigned after the wheel size model number.
- **Defrost Control** - Optional monitoring and wheel control that will keep frost from forming, or melt the frost if it has formed.
 - **Mode** - Selectable activation type for frost control.
 - **OA Temp SP** - If Temp/RH defrost is selected, the outside air temp must be below set point for the ERV to enter defrost mode.
 - **EA Temp SP** - If Temp/RH defrost is selected, the exhaust air temp must be below set point for the ERV to enter defrost mode.
 - **RA RH SP** - If Temp/RH defrost is selected, the return air RH must be above set point for the ERV to enter defrost mode.
 - **On Time** - Set time in which the enthalpy wheel spins at the defrost wheel speed setting.
 - **Off Time** - Set time the ERV cannot activate into a defrost cycle after a cycle has completed.
 - **Speed** - Adjustable speed which the user may set the enthalpy wheel speed during defrost cycle.
- **Wheel Cleaning** - Wheel cleaning settings.
 - **Mode** - Selectable activation modes for wheel cleaning cycle.
 - **On Time** - Amount of time the cleaning cycle is on when activated. This is only applicable if the wheel clean mode is set to automatic.
 - **Off Time** - Amount of time that if the ERV is continuously off will activate a cleaning cycle. This is only applicable if the wheel clean mode is set to automatic.
- **Min OA Damper Pos** - Adjustable set point to dictate when the ERV can activate. The damper must be open more than this setpoint in order for the ERV to activate tempering.
- **Staging Control** - Adjustable time value that corresponds to the staging of the ERV and Roof Top Unit (RTU).
 - **ERV Time** - Timer that determines how long the host unit must be at minimum capacity before it stages off and only ERV is used for tempering.
 - **DOAS Time** - Timer that determines how long the ERV must be at maximum capacity before the host unit stages on.

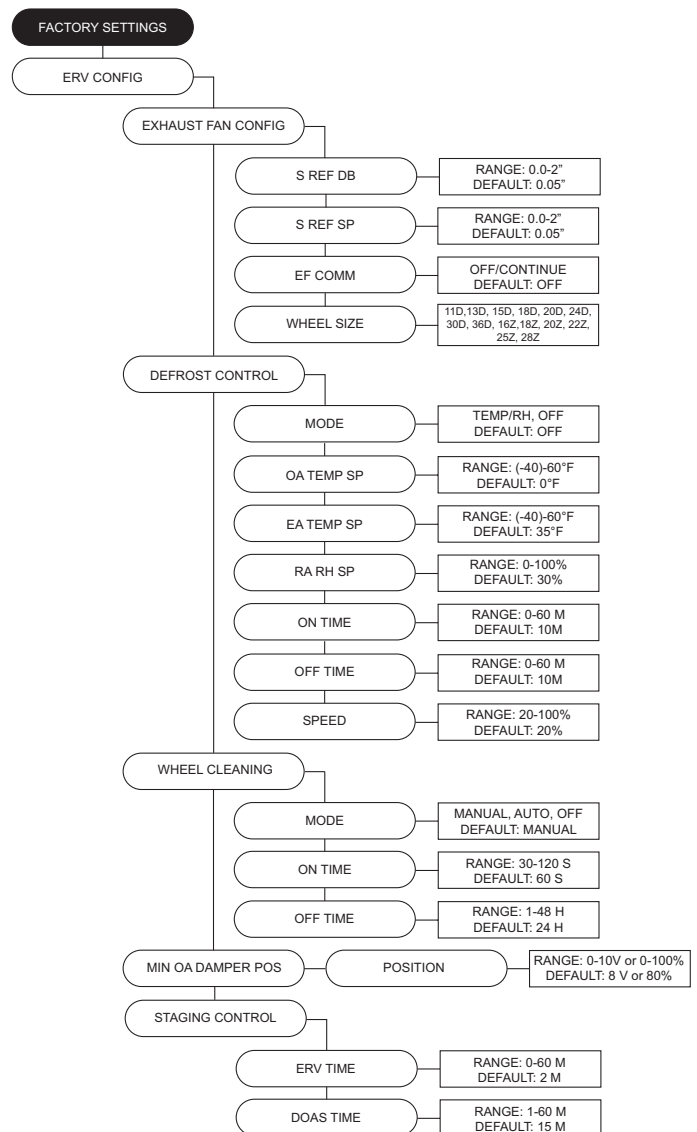

Occupancy Config

- **Scheduling** - This menu is where scheduling may be turned On or Off.
- **Override** - Allows the user to override the current occupied settings.

Unit Options

- **Board Config**
 - **Unit Address** - Modbus address of the MUA board.
 - **Startup Timer** - Time upon power-up where the board will sit idle.
 - **Temp Units** - Allows the user to set temperature units. Changing between the two will reset all set points. The board will reset as well.
- **HMI Config**
 - **Number** - The number of HMIs connected to the MUA board. Must always be at least one.
 - **Dis Space** - Select display space temperature option. Faceplate will display the room's current temperature. Average will display an average of all faceplates, excluding HMI in the unit, and all wired space sensor readings.
 - **Screensaver** - If set to Off, the home screen will not time out to the screensaver.
 - **Average HMI** - If there are multiple space HMIs connected, this menu allows you to select which will be included in the space temperature and relative humidity averaging. If a thermistor or relative humidity sensor is connected into the ST screw terminals, it will automatically be averaged into any HMIs included.
 - **Temp Stat #** - On/Off option to turn on temperature averaging for wired HMI thermistors.
 - **Lock HMI** - If the option is set to On, a password (9999) will be required; when screen saver option enabled or any buttons are not pressed for 5 minutes.
 - **Scnsvr Disp** - User may select date, time, and/or temperature/RH to display on the HMI when screensaver is active.
- **DDC Main Config**
 - **Baud** - The baud rate of the Modbus communications.
 - **Word Bits** - The amount of data bits over Modbus communications.
 - **Parity** - Selection for Modbus communications.
 - **Stop Bits** - Selection for Modbus communications.
- **PGA HW Type** - (DO NOT CHANGE SETTINGS)
- **BMS User Write** - Allows BMS writing to user settings.
- **BMS Factory Write** - Allows BMS writing to factory settings.
- **Timer Config** - (DO NOT CHANGE SETTINGS)
- **PWM Output Delay** - Delays PWM output for Condensing Fans, Blower, and Gas Valve for smooth modulation.
 - **Cond Fan** - Time setting.
 - **Blower** - Time setting.
 - **Gas Valve** - Time setting.

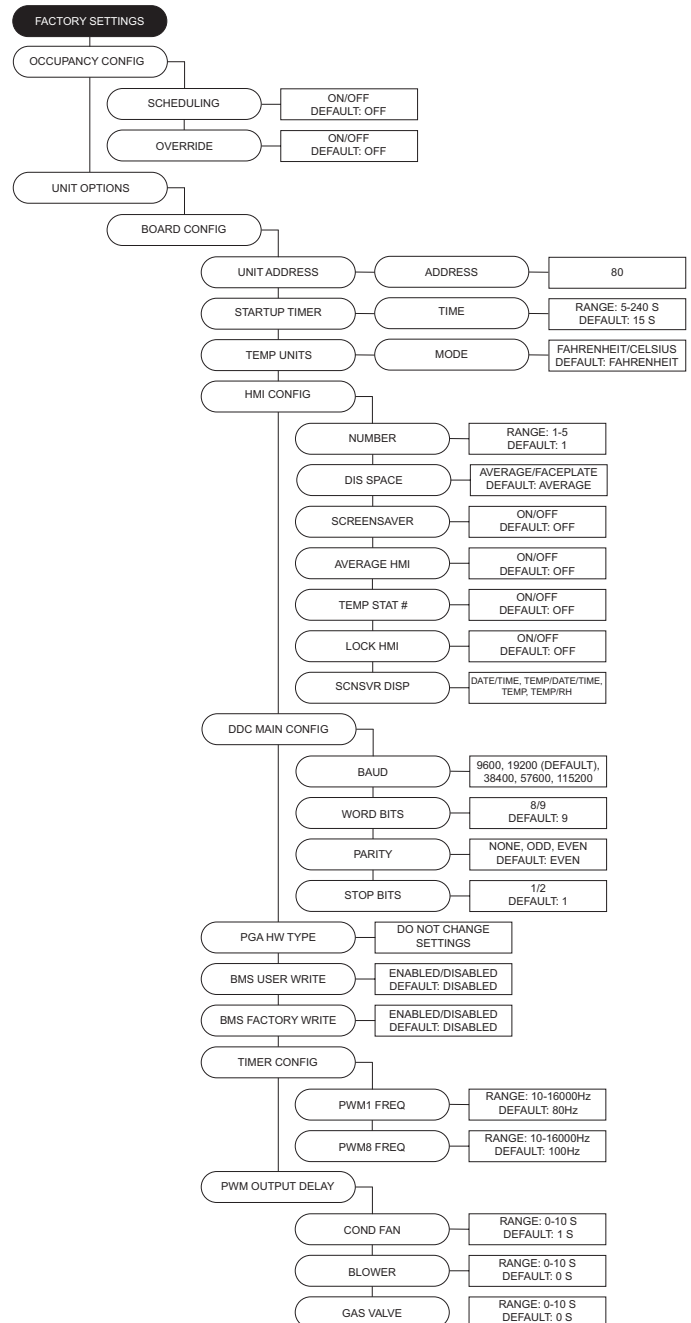

• **Blower Config**

• **Blower Control**

- **120V Contactor** - 120V output on the MUA board to energize the coil of a contactor.
- **ECP** - This option should be selected when the supply fan VFD is wired to a hood control package control board via CAT5 cable.
- **VFD Manual** - HMI selectable VFD frequency.
- **VFD Jog** - For use with VFD using photohelic control. Uses the aux pins to control the VFD. Powering “Aux 1” will speed the fan up, powering “Aux 2” will slow the fan down. When neither “Aux 1” nor “Aux 2” are powered, the VFD will hold current speed.
- **VFD 0-10V** - For use when an external 0-10V signal is being provided to control the speed of the VFD.
- **VFD Pressure** - For use when the VFD is controlling speed based on space or duct pressure.
- **ECM (Electronically Controlled Motor)** – HMI selectable supply fan rate.
- **ECM 0-10V** - For use when an external 0-10V signal is being provided to modulate the ECM supply output between min and max speed.
- **ECM Pressure** - For use when the ECM is controlling speed based on space or duct pressure.

• **Blower Mode:**

- If the “Occupied Scheduling” is set to On, the menu screen for the blower mode will allow you to choose ON/AUTO/OFF for Occupied or Unoccupied.
- If the “Occupied Scheduling” is set to Off, the menu screen for the blower mode will allow you to choose MANUAL/AUTO/OFF.
- In blower AUTO mode, the blower will only run when it gets a call for heating/cooling.
- In blower ON mode, the blower will run as long as the fan button is enabled regardless of whether the unit is heating/cooling.
- In blower OFF mode, powering the unit interlock pin will cause the blower to run.

• **Airflow Proving** - Unit may be set to prove by an external airflow switch, remote 0-10 V input signal, or from the onboard switch (connector J39).

- **Control** - Onboard, remote, or switch.
- **PS Set Point** - PS Set Point should be 0.05” w.c. below the lowest static pressure reading that is observed.

• **Blower Delay Enable** - User may set the blower start/stop delay to Off/Both/Cool/Heat.

• **Blower Delay Time** - A time setting delay for the start or stop of the supply blower before/after selected tempering starts/stops.

• **Door Interlock** - When enabled, a “Door Interlock” fault will display when the blower door is open during normal operation.

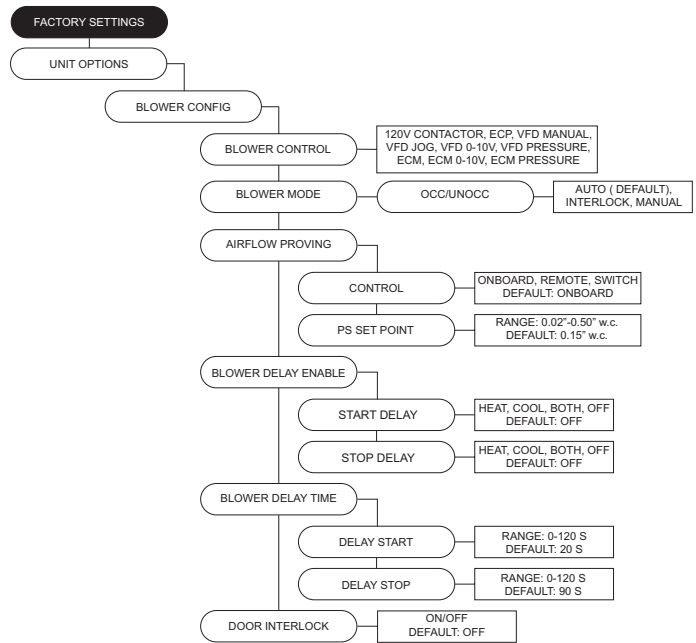

- **Fan Proving Config** - Proving for fan operation.
 - **Proving** - When enabled, a fault detected will display when not operating.
 - **Retry** - When enabled, the unit will try to automatically reset upon airflow proving failure. After a second failed attempt, a manual reset will be required.
 - **# Contactors** - Number of exhaust fan contactors.
 - **Exh Fan** - If exhaust contactor fails proving, while “Exh Fan” is set to On, all fans shut down. When “Exh Fan” is set to Alarm Only, only post proving faults but allow fans to keep running.
- **DD Wheel Size** - Selection for wheel size and settings.
 - **Size** - This selection is utilized for CFM monitoring. Dual blower models will have a ‘2’ assigned after the wheel size model number.
 - **K2 Factor** - Used for supply CFM calculations.
- **Blower Presets** - User may set blower preset option On/Off.
 - **Occ/Unocc Fan Presets** - After the blower has started, energizing the auxiliary pins will drive the blower to a preset occupied value.
 - Fan Preset Default: 1 = 0Hz, 2 = 40Hz, 3 = 50Hz, 4 = 60Hz, 5 = 0Hz, 6 = 0Hz, 7 = 0Hz.
 - **Occ/Unocc PWM Presets** - After the blower has started, energizing the auxiliary pins will drive the blower to a preset occupied value.
 - PWM Preset Default: 1 = 0%, 2 = 80%, 3 = 100%, 4 = 100%, 5 = 0%, 6 = 0%, 7 = 0%.
- **VFD Direction** - Sends a command to the VFD to run in forward or reverse.
- **VFD Freq Limits** - Min to Max settings for fan speed.
 - **VFD Current Limit** - This limits the max current to the VFD.
 - **PWM Rate Limits** - Min to Max settings for fan speed using ECM.
 - **Constant CFM** - When enabled On, blower will modulate to maintain constant CFM.
 - **Max Step** - Modulation adjustment; EC motors = %, VFD = Hertz (HZ).
 - **Pressure Config**
 - **Sensor Range** - Menu is available when any blower pressure or mixing box pressure option is selected. This sets the pressure range for the transducers that are wired to the board – possible transducer ranges are +/- 15”w.c. or +/- .25”w.c. PS1 is wired to the J31 connector and PS2 is wired to the J16 connector.
 - **Static PS KP** - Proportionally constant value for static pressure measured in V/sec.
 - **Cycle Time** - Cycle time is the time between two consecutive readings.
 - **Static PS Hysteresis** - This is the hysteresis band used for the static pressure set point (SP).
 - **PS Control Types** - Used to assign PS1 or PS2 to exhaust, blower, or damper control. PS1 is the transducer wired to J31 and PS2 is the transducer wired to J16.

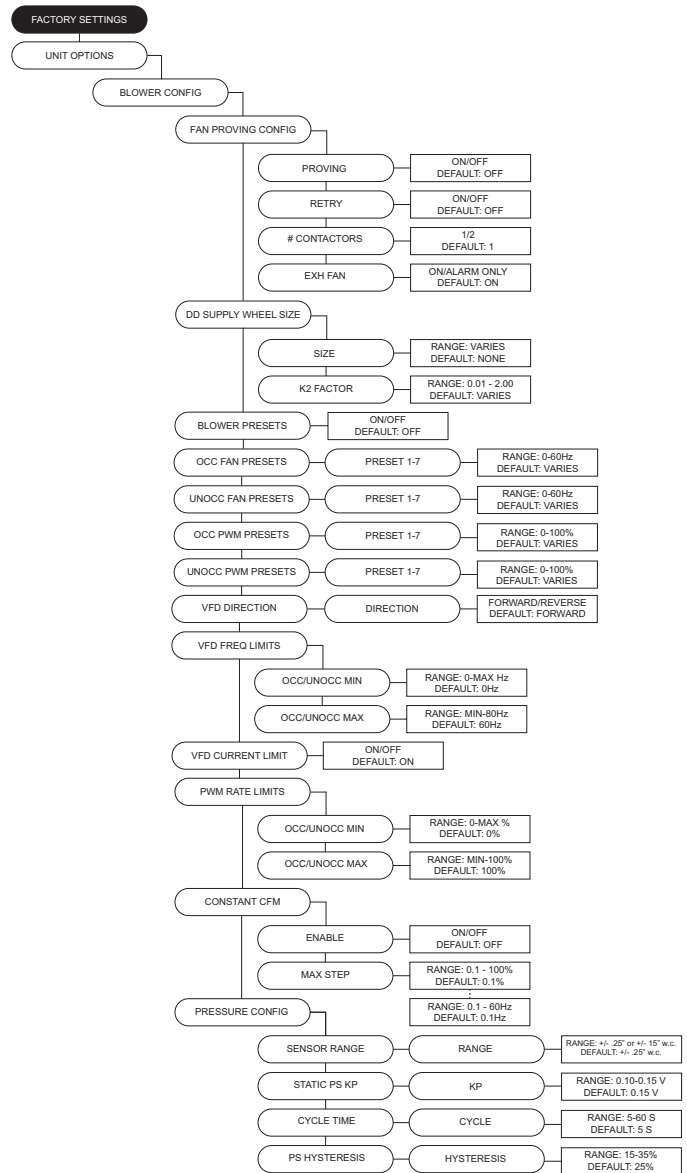

Table 13 outlines the aux pins on Connector J11 for preset settings associated with fan speed and damper position found in **Factory Settings > Unit Options**. **NOTE: When dehumidification is enabled (Aux 1), fan or damper preset speeds will not work.**

Table 13 - Aux Presets

Presets	Aux 1	Aux 2	Aux 3
Normal Operation (Selected Blower Mode)			
Fan Speed/Damper Position 1	X		
Fan Speed/Damper Position 2		X	
Fan Speed/Damper Position 3	X	X	
Fan Speed/Damper Position 4			X
Fan Speed/Damper Position 5	X		X
Fan Speed/Damper Position 6		X	X
Fan Speed/Damper Position 7	X	X	X

• **Purge Config**

- **Purge Button** - When enabled On, a purge button will be displayed on the HMI. When the purge button is pressed, the damper will open to max outdoor air and turn on the exhaust contactor.
- **Purge Time** - This is the amount of time that the unit will run the purge process if the user does not stop the purge manually.
- **Purge Speed** - Adjustable between VFD Min and Max frequency. This is the speed the blower will run during the purge cycle. ECM Purge Speed – Adjustable between PWM Min and Max frequency.

• **Dry Mode Config** - When this option is enabled, dry mode will activate when indoor conditions are above DP setpoint and outdoor conditions are more favorable than indoor conditions. Dry mode will force the damper to 100% OA and energize an exhaust contactor if one is configured.

- **Exhaust** - Enables/disables exhaust contactor during dry mode.
- **Space DP SP** - Dew point threshold for automatic dry mode activation.
- **Space DB SP** - Dry bulb threshold for automatic dry mode activation.
- **Space DP Hyst** - Applies hysteresis value to dew point setting.
- **Summer Vent** – When enabled, dry mode activated on a dry bulb temperature instead of DP.
- **CTR CTRL** - J29-7 will energize per the selected option.

• **Monitoring Sensors** - This menu enables optional components from the factory or when field installed.

- **Smoke Detector** - Enables for smoke detection.
- **Filter Mon** - The option may be set to Off, Contacts or Sensor (J31-14). When set to Contacts or Sensor, if the input is active a fault will be displayed on the HMI.
- **Intake Firestat** - When enabled, if the intake sensor is above the intake firestat set point, the unit will shut down immediately. A manual reset must be performed on the HMI.
- **Discharge Firestat** - When enabled, if the discharge sensor is above the discharge firestat set point, the unit will shut down immediately. A manual reset must be performed on the HMI.
- **Freezestat** - When enabled, if the freezestat sensor trips, the unit will shut down immediately. A manual reset must be performed on the HMI.
- **Freezestat RA** - When enabled and the freezestat trips, the unit will go to full return air.
- **Low Gas Switch** - When enabled, if incoming gas pressure drops below threshold, heating will shut down.
- **High Gas Switch** - When enabled, if incoming gas pressure rises above threshold, heating will shut down.
- **2nd S Line Temp** - When enabled, a second suction line sensor will be used for redundancy.
- **CO Shutdown** - When enabled, if J12-6 reaches 10V, shut down the unit (blower, heating, and cooling).
- **PT Max Config** - Select pressure range for suction line, discharge line, or liquid line sensors.

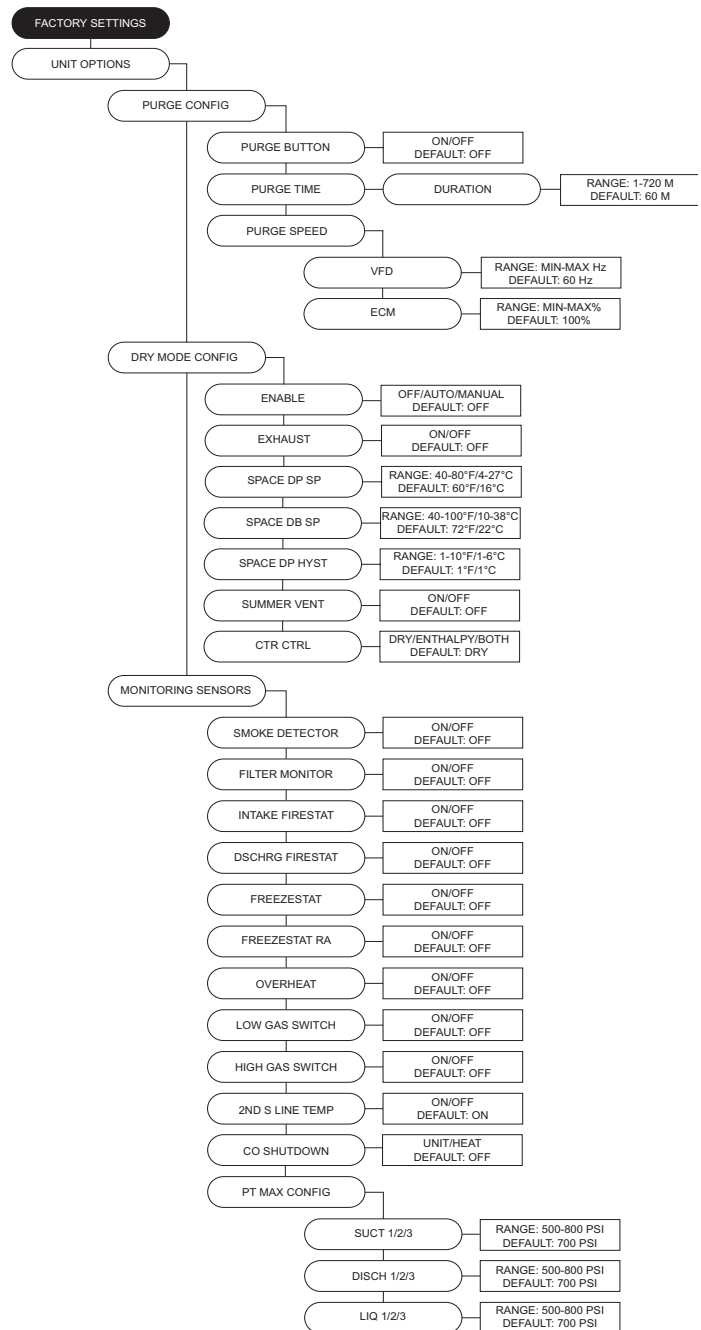

- **High Duct PS Config** - When enabled, if duct pressure is greater than the set point for longer than the set time, heating/cooling will shut down. A fault will be displayed on the HMI.

- **Time** - Setting for how long the unit can be outside of its pressure range.

- **PS Lim**- Duct pressure alarm set point.

- **Bldg PS Config** - When enabled, if the building pressure is lower/greater than the set point for longer than the set time, heating/cooling will shut down. A fault will be displayed on the HMI.

- **Time** - Setting for how long the unit can be outside of its pressure range.

- **Low PS Lim** - Low pressure alarm set point.

- **High PS Lim** - High pressure alarm set point.

- **Weighted Avg Temp** - Averages Temperature

- **Weighted Avg RH** - Averages Relative Humidity

- **Weighted Avg CO2** - Averages CO2

- **Weighted Avg PS** - Averages Pressure

When Weighted settings are enabled On, weight (WT) and lock (LK) adjustments are active. Use WT to assign Space priority monitoring. Use LK when you want specific WT assignments on certain HMIs.

- **Over DP Config** - When enabled, if discharge DP is greater than over dewpoint set point for the set time, shut down the unit.

- **Set Point** - Max discharge dew point allowed.

- **Timer** - Time allowed for DP set point overshoot before unit shutdown.

- **Outdoor Air Config**

- **Outdoor Air Control** - Off, Manual, 2 Position, Outdoor Air %, Analog Control, Pressure, 100% OA.

- **Outdoor Air Deadband** - If the temperature difference between the outdoor and return sensor is less than or equal to this set point, the MUA board will not attempt to adjust the output voltage until it matches the outdoor air percentage set point. This setting only takes effect when either outdoor air % or schedule is selected.

- **Return As Space** - When enabled On, unit will utilize the return air temperature and humidity sensor as the space reading.

- **Outdoor Air Limits** - Minimum and maximum settings for mixing box. Percentage or voltage based on mixing box selection.

- **Min/Max Outdoor Air %** - Minimum and maximum allowed outdoor air percentage.

- **Min/Max Outdoor Air** - Minimum and maximum allowed outdoor air voltage range.

- **Preset OA Values** - If set to On, the preset OA value calibration must be performed. Calibration will analyze return air temp, outside air temp, and intake air temp, in order to populate a table of OA% vs damper voltage. User may set an OA% and the table will be referenced to determine the corresponding damper voltage.

- **Edit OA% Table** - User may edit values in 1/2 volt increments (0-10V). Volt value corresponds to % value.

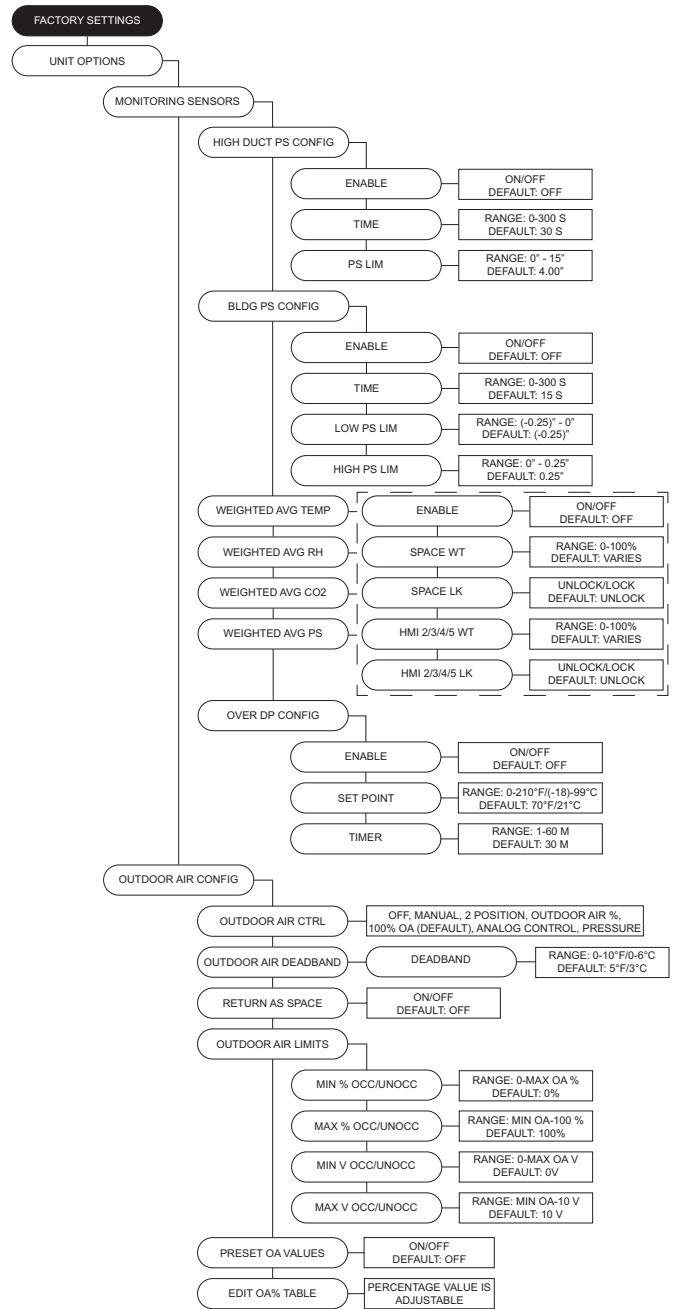

- **Economizer Config** - Refer to “**Economizer**” on page 101.

- **Economizer Mode** - Off, Fixed Dry Bulb, Diff (Differential) Dry Bulb, Fixed Enthalpy, Diff Enthalpy.

- **Economizer Act** - Option to set the economizer to activate on cooling only, or cooling and blower.

- **Disable Cooling** - When the economizer is using an outside air % greater than this setting, mechanical cooling will be disabled.

- **Modulating Econo** - Mixing box will modulate to meet Modulating Econo > Intake SP.

- **Intake SP** - Unit will modulate to meet Intake SP.

- **Damper Presets** - This allows the user to set damper preset voltage option On or Off. Refer to **Table 13** on page 83 for Aux Presets.

- **Damper Preset Volts** - User may set damper speeds.

- **Occ Damper Presets** - User may set occupied damper speeds.

- **Unocc Damper Presets** - User may set unoccupied damper speeds.

- **Room Override** - If set to On, the unit will use the Room Override SP rather than Discharge SP. This setting should only be used when heat tempering mode is set to “Discharge” and “Activate Based On” is set to “Either.” When the space is calling for heat, it will use the Room Override SP instead of Discharge SP to heat the space.

- **Exhaust Contactor** - This allows the user to assign a contactor for an interlocked exhaust fan. There is an occupied and unoccupied setting for this.

- **None**

- **Before Airflow:** Exhaust fan will start before the airflow proving switch has been activated.

- **After Airflow:** Exhaust fan will start after the airflow proving switch has proved there is airflow.

- **Exhaust On Smoke** - Input that when enabled, if it receives a 120V signal from a fire system, will shut down the supply fan, enable the exhaust contactor, and drive damper position to exhaust on smoke damper setting.

- **Damper** - When Outdoor Air Control is set to manual = Volts. When Outdoor Air Control is not set to manual = Percentage. If powered exhaust on fire is enabled, powered exhaust on fire will override the damper position setting.

- **Exhaust Speed Ref** - When enabled On, the exhaust speed will match supply blower VFD.

- **Unit Heaters** - On/Off selection for heater options.

- **Trouble Input** - If connector J28 pin 3 receives 24 volts, the unit will act based on one of the following settings:

- **Mode**

- **Unit Off** - Shuts down blower (heating/cooling will also shutdown). Bypass any timers.

- **Both Off** - Turn off/lockout heating and cooling. Bypass min timers.

- **Heat Off** - Turns off/lockout heating.

- **Cool Off** - Turns off/lockout cooling. Bypass min timers.

- **Set Back** - Forces unit to unoccupied state.

- **Time** - Turn off/lockout delayed based on time setting.

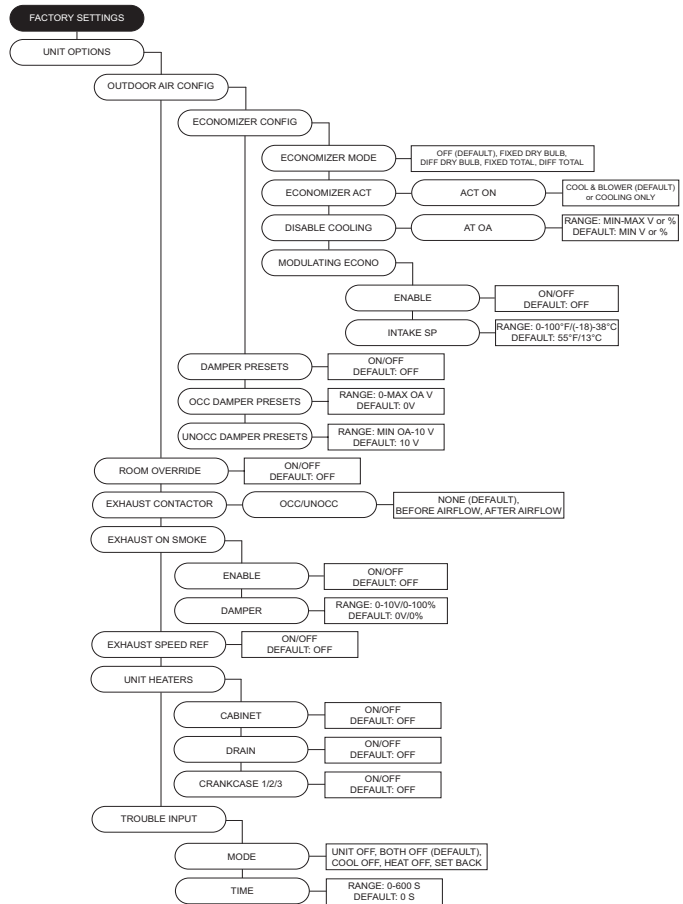

• **Powered Exhaust**

• **Control** - Operates on Building PS, 0-10V (external field wiring), or Manual (0-10V board output specified in "User Settings" to exhaust blower).

• **Min/Max Fan Speed** - The powered exhaust should never go below min speed or above max speed.

• **Outdoor Reset** - Access to setting option On/Off. Scenarios for Outdoor Reset functionality:

- Discharge Heat Tempering: If outside air is below OA Reset Low set point, heat will discharge to Reset Heat Discharge setting.

- Space Heat Tempering: If outside air is below OA Reset Low set point, space set point will adjust to Reset Heat Space setting.

• **Dynamic Set Point** - Dynamic functionality will adjust the heating and cooling setpoints based on outside air temperature. When heating: If the measured outside air temperature is below the Dynamic Heat OA set point minus the differential set point, the space or discharge set point will increase by offset. When cooling: If the measured outside air temperature is above the Dynamic Cool OA set point plus the differential set point, the space or discharge set point will decrease by offset.

• **Dehumid Input** - Option associated with units that contain reheat. Set to Off when the unit does not contain reheat, set to On when unit contains reheat.

• **CO2 Control Config** - Monitors CO2 and will adjust blower speed/damper position based on CO2 set point.

• **Override** - The unit will try to maintain space CO2 Parts Per Million (PPM) levels based on adjustable min/max threshold set points. The unit will modulate the blower/damper linearly between corresponding set points.

• **Threshold** - CO2 PPM maximum threshold set points for the space. When the space CO2 PPM reading exceeds the threshold setting, the blower/damper will go to their max setting.

• **Single Zone VAV** - When enabled the blower, damper, or both (depending on settings), will modulate linearly between min and max discharge.

• **Invert** - In normal operation the blower/damper will go to max speed or position when the heating/cooling/dehumidification capacity is at the max. In inverse operation, the blower/damper will go to max speed or position when the heating/cooling/dehumidification capacity is at the min.

• **Virtual Space Input**

• **Temp** - Utilizes a virtual space temp reading through the BMS instead of the hard-wired space temp sensor.

• **RH** - Utilizes a virtual space relative humidity reading through the BMS instead of the hard-wired space relative humidity sensor.

• **Input Timer** - Utilizes wired sensor if Virtual signal goes stale for timer duration.

• **Pool Room** - Enable this option for pool room applications.

• **Dew Point** - When above the dew point setpoint (SP), the blower will modulate to the pool room's blower speed setting.

• **DP Hyst** - Hysteresis value is applied to dew point SP.

• **Speed** - Blower speed adjustment for high dew point pool rooms.

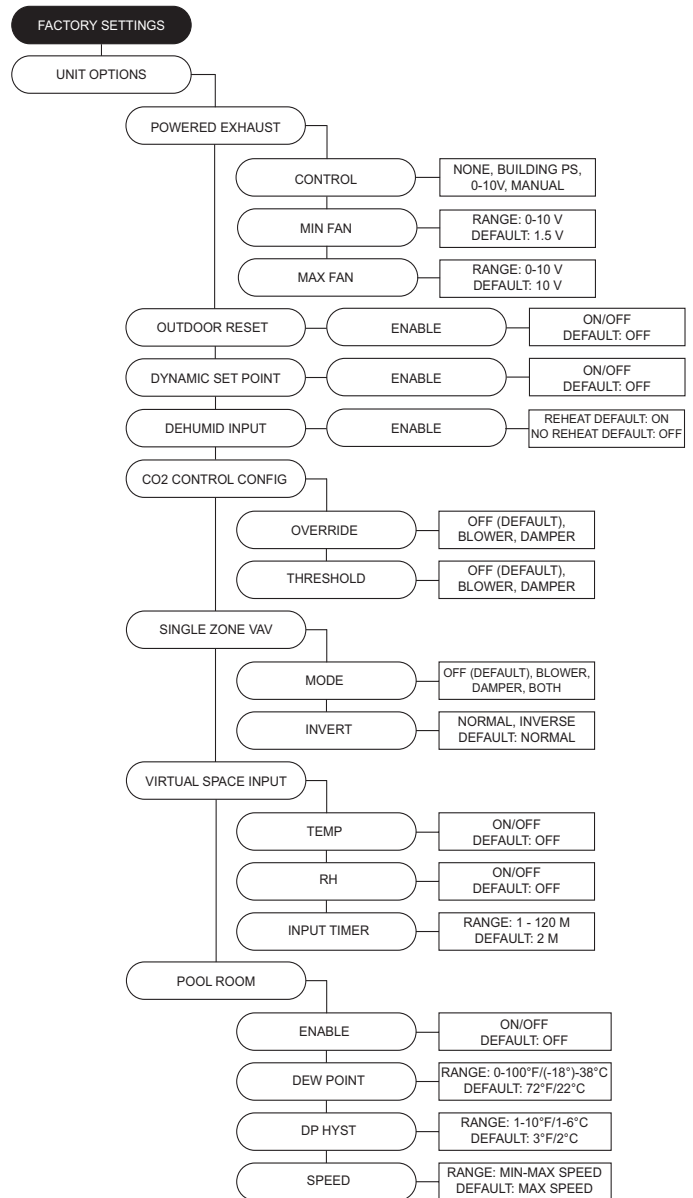

- **Unit Performance** - Adjustable points for monitoring. For service settings, go to Service > Unit Performance.
 - **CFM** - Design CFM.
 - **Min/Max Duct SP** - Design duct static pressure.
 - **Min/Max Building SP** - Design building static pressure.
 - **Mtr Eff** - Motor Efficiency.
 - **BHP** - Brake Horsepower.
 - **D Freq** - Design Frequency.
 - **D ECM** - Design Percentage.

Occpd Ovr (Occupancy Override) Duration - Length of override timer. If override is active, it can be manually stopped by pressing the end override button on the HMI. The default setting is 1 hour but can be adjusted up to 16 hours.

Limit SP Adjust - This allows the user to change the current temperature set point through the home screen. The adjustment range can be 0-100 degrees. Default range max is 5F. When the set point is set to 0F, the adjustment buttons (+/-) will not be visible.

Temp Ovr Duration - Length of temperature override timer.

PID Config - Protected Parameters (DO NOT CHANGE THESE PARAMETERS)

Sensor Offsets: Offsets for temperature, and humidity. These offsets only impact the display and do not impact the value that the logic uses for control.

- **Dschrg Disp Offset** - Displays offset for discharge temp. This can be used if actual discharge temperature is measured differently from what is being displayed.
- **Space Disp Offset** - Displays offset for space temperature. This can be used if actual space temperature is measured differently from what is being displayed.
- **Dschrg RH Offset** - Displays offset for discharge humidity. This can be used if actual discharge humidity is measured differently from what is being displayed.
- **Space RH Offset** - Displays offset for space humidity. This can be used if actual space humidity is measured differently from what is being displayed.
- **Onbrd PS** - Displays onboard pressure sensor. Non-configurable setting.

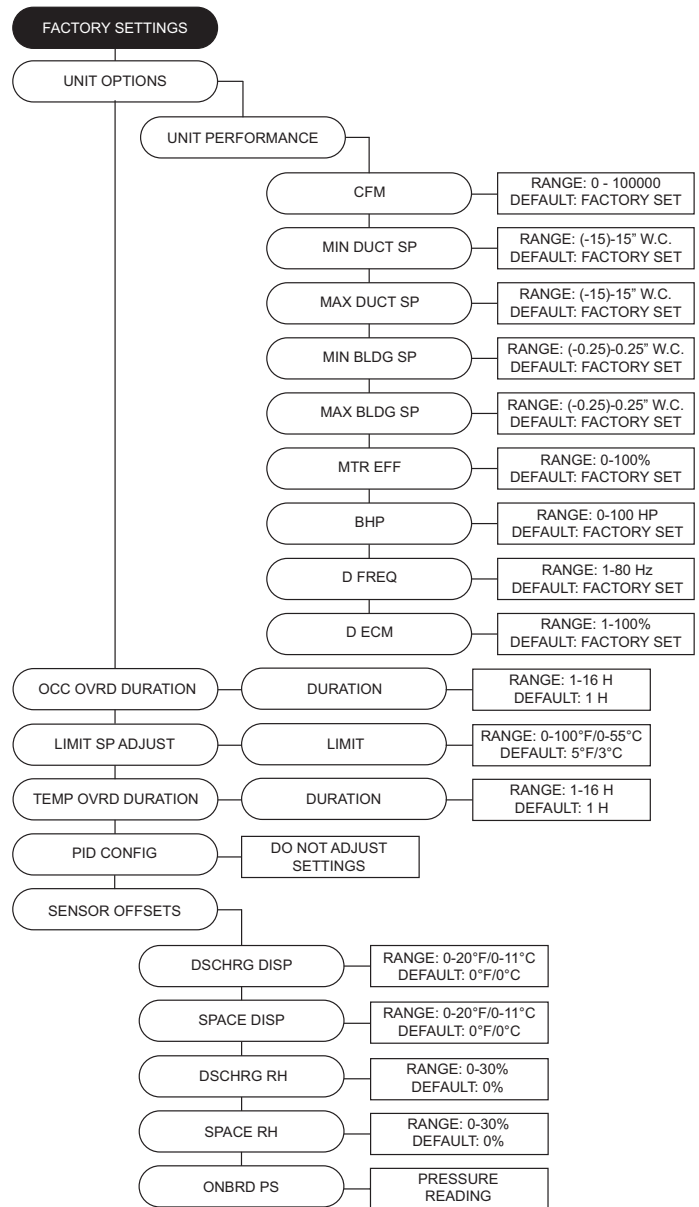

SERVICE SETTINGS - Factory Menu Password = 1234

Temperatures - Display monitoring for temperature values.

RH Values - Current RH value readings per HMI.

CO2 Values - Current CO2 value readings per HMI.

Pressure Values - Current Pressure readings per HMI.

Open/Closed Status - View open/closed status of all inputs.

Variable Values - Monitor all of the variable input and output values.

Blower VFD Status - Live parameter feedback from the supply VFD.

Comp VFD Status - Live parameter feedback from the compressor VFD.

Refridge Diag 1 - This allows the user to monitor refrigerant components, pressures, and temperatures for circuit 1.

Refridge Diag 2 - This allows the user to monitor refrigerant components, pressures, and temperatures for circuit 2.

Refridge Diag 3 - This allows the user to monitor refrigerant components, pressures, and temperatures for circuit 3.

Outdoor Air Values - Displays the high/low airflow limits, and calculated actual outdoor air percentage.

ERV Diagnostics - Displays ERV performance and diagnostic values.

- **Current Performance** - Displays ERV state, ERV wheel speed, exhaust fan speed, and wheel differential pressure.
- **Temp and RH** - Displays temperature and RH values for every quadrant. Also calculates enthalpy at every point.
- **ERV Pressure** - Real time values for monitoring ERV pressure parameters. Stores based values for pressure faults. These values can be adjusted manually or through the ERV calibration process.

Vapor Pressure - Displays vapor pressure readings.

ERV Exhaust CFM - Displays measured ERV CFM readings. This readout is only valid for units with direct-drive wheels.

Supply CFM - Displays measured CFM readings. This readout is only valid for units with direct-drive wheels.

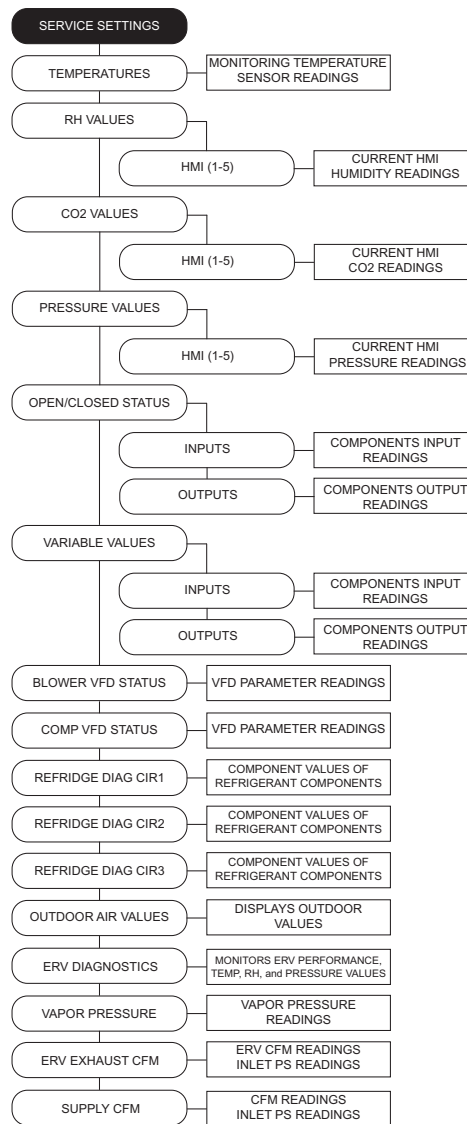

Unit Performance- Compares Unit Options > Unit Performance to current unit's operational values.

- **Dsn CFM** - Design CFM. Job specific unit CFM.
- **Act CFM** - Actual CFM. Current unit CFM reading.
- **Min/Max Dsn D SP** - Design duct static pressure. Job specific external static pressure.
- **Min/Max Dsn B SP** - Design building static pressure. Job specific external static pressure.
- **Act D SP** - Actual duct static pressure. Current external static pressure.
- **Act B SP** - Actual building static pressure. Current external static pressure.
- **Act BHP** - Actual Brake Horsepower.
- **Mtr Delta** - Motor Delta. Temperature rise caused by motor heat.
- **MHG** - Motor Heat Gain. BTU rise caused by motor heat.
- **HT Cap** - Heating capacity output in MBH.
- **HT KW** - Heating output in kilowatts.
- **Rht Delta** - Reheat Delta.
- **R Cap** - Reheat Capacity.
- **E Cap** - Evaporative Capacity.
- **Cool Tons** - Cooling Tonnage.
- **D Cap** - Discharge Capacity.
- **Delivered Tons** - Unit delivered tonnage.

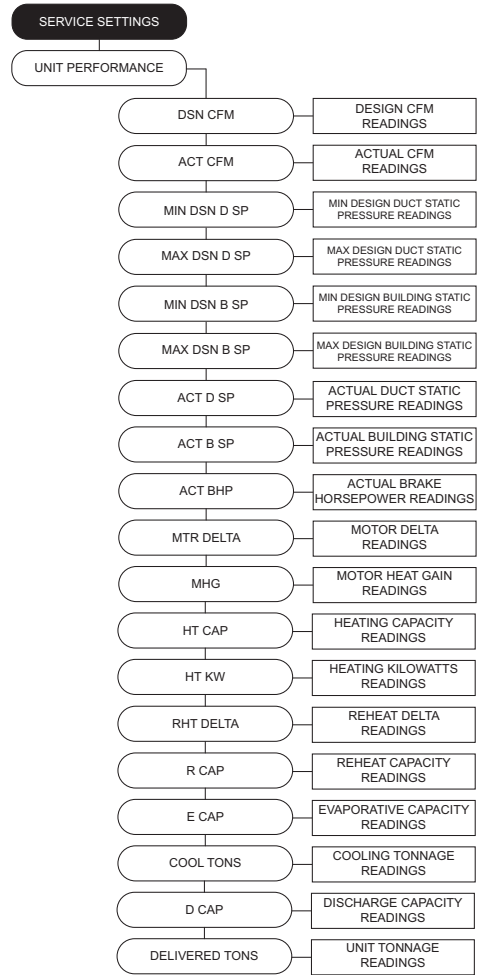

Test Menu

- **Test Fans** - Test operation of unit's fans.
- **Test Heating** - Contains high fire, low fire, and analog tests. The analog test simulates a voltage input from a BMS system. The test begins at 0 volts. Allows blower and damper modulation. Pressing up/down modulates input.
- **Test Cooling/HP** - Test cooling, heat pump, or analog system. Monitor adjustments and parameters during testing. The analog test will simulate a voltage input from a BMS system. The test begins at 0 volts. Allows blower and damper modulation. Pressing up/down modulates input.
- **Evacuation Mode** - Only to be used when working on the cooling system. All refrigeration valves in the circuit will be open during evacuation.
- **Service Safe Stop** - Unit shutdown with pumpdown off.
- **Test Stepper Motor** - Displays valve position when testing EEV or Reheat valves.
- **Test ERV** - Manually adjustable values when testing ERV Exhaust Fan, Wheel, or All.
- **Test Economizer** - Manually adjustable values when testing in Cool or Blower.
- **Test Options**
 - **Test Cabinet Heater** - Beginning this test will activate the cabinet heater on.
 - **Test Drain Heater** - Beginning this test will activate the drain heater on.
 - **Test Crankcase Heater** - Beginning this test will activate the crankcase heater on.
 - **Test OA Ctrl** - Beginning this test will create an output to the outdoor air control. The test will begin at 0 volts. Pressing up/down modulates the output.
 - **Test Freezestat** - Test menu will allow user access to adjust set points to verify freezestat operation in various types of ambient conditions.

Clear Fault History - This will clear the entire fault history. If there is an active fault when cleared, that fault will show up until it is fixed.

Set Clock - Set day and time.

Cal Static Duct PS - Calibrates duct pressure. Must disconnect all pressure tubes before calibration.

Cal Static Build PS - Calibrates static building pressure. Must disconnect all pressure tubes before calibration.

Calibrate Supply CFM - Calibrates pressure differential in the venturi to calculate approximate fan CFM. Must disconnect all pressure tubes before calibration.

Supply CFM - Calibrates pressure differential in the venturi to calculate approximate fan CFM. Must disconnect all pressure tubes prior to calibration.

Calibrate ERV - Calibrates pressure differentials across all filters and energy wheel.

ERV Service Mode - Allows user to control damper, supply, and exhaust fans.

Update Factory Defaults - This allows the original factory default settings to be overridden. When confirming the updated settings, these settings will now be used when "Factory Reset" is needed.

Factory Reset - Resets board to factory commissioned settings.

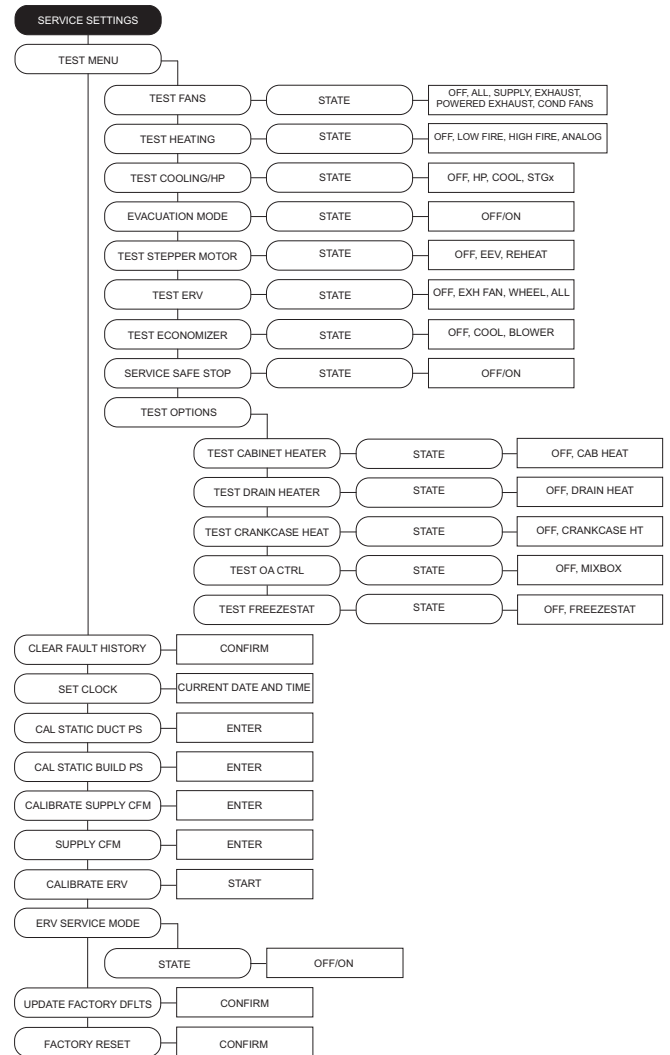

UNIT OPERATION

WARNING: Gloves and safety glasses must be worn when servicing refrigeration equipment.

Before starting or operating the unit, verify all fasteners are secure and tight. In particular, check the set screw in the wheel hub. Verify power and gas are **OFF** to the unit. Before connecting the unit to power, turn the fan wheel by hand to verify it is not striking the inlet, or there are any obstructions. Re-center, if necessary.

Special Tools Required for start-up: AC Voltage Meter, Standard Hand Tools, Differential Pressure Gauge, Thermometer, Tachometer, Amperage Meter, Refrigeration Gauge Set

Start-Up Procedure

1. Check all electrical connections are secure and tight.
2. Inspect the condition of the intake damper and damper linkage, if applicable.
3. Inspect the air-stream for obstructions. Install necessary filters.
4. Verify all drains are connected and routed in the proper positions. For high-efficiency furnaces, verify the condensate drain is connected. Refer to **“Furnace Condensation Drain” on page 18.**
5. Compare the supplied **motor voltage** with the fan’s nameplate voltage. If this does not match, correct the problem.
6. Check the rotation of the wheel motor. Verify the wheel is moving in the direction of the directional arrow (**Figure 42**). Incorrect rotation will result in poor air performance, motor overloading, and possible damage to the motor. If the motor rotation is incorrect, adjust using the HMI panel. Go to: **Factory Settings > Unit Options > Blower Config > Supply VFD Direction > Forward.**
7. When the fan is started, observe the operation and check for any unusual noises.
8. Connect a refrigerant gauge set to the system. Refer to **“Monitoring the A/C System” on page 110.** Verify the high side and low side pressure readings are equal at the initial connection.
9. Monitor the surface temperature with a thermometer.
10. Start and run the unit for approximately 20 minutes.
11. Monitor the manifold gauge, surface temperature, subcool, and superheat readings:
 - Refer to **Table 17 on page 134** to convert the pressure gauge readings to temperature.
 - The subcool reading should be approximately **10-20°F**.
 - The superheat reading should be approximately **20°F**.

Figure 42 - Direction of Rotation

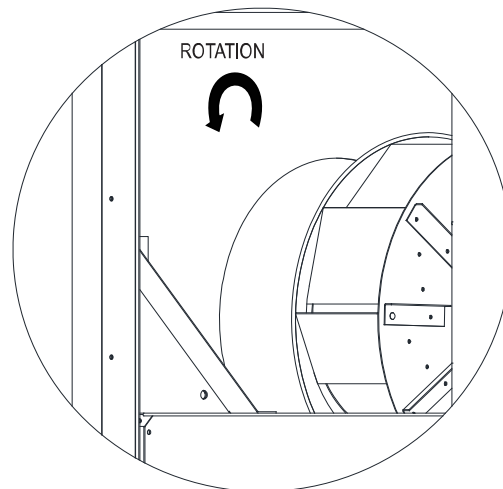

Start-Up Procedure Heating

Furnace Start-Up Summary

1. Open the field-installed manual gas shut-off valve and ensure the On/Off gas control valve knob is set to 'On.'
2. Check inlets to all firing tubes on the furnace and ensure that they are all clear of foreign debris. Verify that the tubes line up properly with each nozzle of the gas manifold.
3. Start the unit and check the gas supply pressure at the inlet gas gauge, this gauge is upstream of all electronic gas valves. The inlet pressure should be **7 in. - 14 in. wc on natural gas or 11 in. - 14 in. wc on propane gas**. If the inlet pressure is too high, install an additional pressure regulator external to the unit.
4. Verify DIP switches are set correctly on the modulating valve (**Figure 43**). Factory setting for DIP switches is Off. Refer to **Table 14** for DIP switch settings.
5. A final gas leak check shall be performed to verify the gas-tightness of the heater's components and piping under normal operating conditions.
6. At any point during high/low fire burner adjustment, check the characteristics of the flames in every firing tube of the furnace. Non-existence of flame or a lazy flame can be caused by no gas pressure, low gas pressure, a dirty nozzle orifice, or clogged section of exhaust flue.
7. When testing has completed, replace all caps and covers removed during the adjustment procedure.

Table 14 - Modulating Valve Dip Switch Settings

Control Signal	SW1 Signal	SW2 Offset	SW3 Characteristic
0-10 V	OFF	OFF	OFF
2-10 V	OFF	ON	OFF
0-2 mA	ON	OFF	OFF
4-20 mA	ON	ON	OFF

High Fire Burner Adjustment

1. Set the unit into high fire mode. This is achieved by configuring high fire by going into the HMI's configuration, refer to "**Accessing Menu Configurations**" on page 61. Go to: **Service > Test Heating > State > High Fire**.
2. Verify the furnace(s) are lighting off properly, the manifold gas pressure should be adjusted to jobsite conditions. The gas pressure regulator (integral to the On/Off gas control valve, refer to **Figure 20**) is adjusted at the factory for average gas conditions. The gas supplied to the furnace must be in accordance with the input rating on the rating plate. Once the gas pressure is verified, continue to step 3.
3. If the unit is set up for analog control, continue with high fire using the method above or send the unit a constant 10V DC or 20mA signal. Refer to **Table 14**.
 - Remove the cover on the modulating valve (**Figure 43**). Read the manifold gas pressure gauge (0-10 in. wc) located directly on the gas manifold. The pressure should read **3.5 in. wc** for natural gas / **10 in. wc** for propane. If the pressure is incorrect, adjust the pressure.
 - To adjust the pressure, press button #1 until the LED lights solid red. Release the button. The valve is now in high fire setting mode.
 - Buttons #1 and #2 are used to set high fire setting. Press once to step or hold to auto step.
4. If the proper (**in. wc**) gas pressure cannot be achieved by adjusting the modulating gas valve, and it has been verified that the inlet gas pressure is within the acceptable range of **7 - 14 in. wc on natural gas and 11 - 14 in. wc on propane gas**, adjust the regulator on the On/Off gas control valve. Use a screwdriver to **turn the inner adjustment screw clockwise to increase the gas pressure, refer to "Gas Conversion Instruction" on page 26**.

IMPORTANT: WHENEVER HIGH FIRE IS ADJUSTED ON THE REGULATOR OR MODULATING VALVE, LOWFIRE MUST BE ADJUSTED OR RE-VERIFIED.

Figure 43 - Modulating Valve and Controls

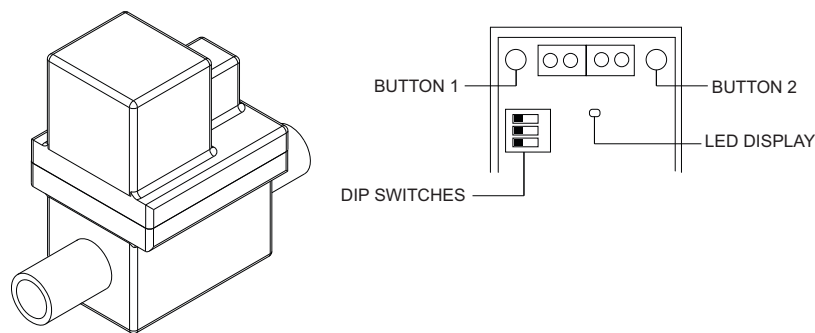

Low-Fire Burner Adjustment

1. Lock the unit into low fire mode. This is achieved by configuring low fire by going into the HMI's configuration, go to: **Service > Test Menu > Test Heating > State > Low Fire**.
2. Press and hold button #2 on the modulating valve until the LED light blinks red. Release the button. The valve is now in low fire setting mode.
3. Press button #1 to increase flow or press button #2 to decrease flow.
 - The desired pressure reading for natural gas is **0.15 in. wc** If this cannot be obtained, set the low fire pressure as low as possible.
 - The pressure reading for propane gas should be **0.75 in. wc**
4. Save the low fire setting by simultaneously holding down buttons #1 and #2 until the blinking LED turns off.

Final Start-Up Procedure

1. With the air and burner systems in full operation and all ductwork attached, measure the system airflow.
2. Once the proper airflow is achieved, measure and record the fan speed with a reliable tachometer. **Caution - Excessive speed will result in motor overloading or bearing failure. Do not set fan RPMs higher than specified in the maximum RPM chart.**
3. Measure and record the **voltage** and **amperage** to the motor and compare with the motor nameplate to determine if the motor is operating under safe load condition.
4. Check for any obstructions, tools, or hardware that may cause damage when unit is in full operation.
5. Make sure all access panels are in place and secure.

Sequence of Operation

Operation Summary - Gas Heating

When there is a call for heat, the main blower is turned “On” and the airflow switch is proven.

- The Flame Safety Controller (FSC-1) sends 120V AC power to the line input of the power vent blower.
- The Power vent blower is controlled by pin J17 on the control board. This varies a signal to the power vent blower motor to initiate a 1 min pre-purge at high speed.
- 24V AC signal runs through the safety circuit (Power Vent Airflow Switch/High Temperature Limit/Flame Roll-out Switch) and into FSC-1.
- FSC-1 initiates Trial for Ignition by sending a signal to the spark igniter to light the furnace and 24V AC power to the On/Off gas valve. This opens the On/Off gas valve and the modulating valve.
- Flame is sensed by FSC-1’s remote flame sensor at the firing tube of furnace.
- HMI’s 17-second high-fire off-delay time sequence runs out, and a variable voltage is sent to the power vent blower motor.
- The control board continues to modulate the heat output of the unit by adjusting the 0-10V DC signal to the modulating gas valve.

NOTE: If a high turndown furnace is present, this sequence occurs with FSC-2 if the call for heat dictates a need for a second furnace.

There are different options for controlling the temperature output of these units. These include Discharge Temperature Control, Space Temperature Control, Analog Control, and Direct Digital Control (DDC). In all cases, the MUA board controls the amount of gas to the burner based on the signal from the temperature control components. When the modulating gas valve is all the way open, achieving the maximum BTUs and temperature rise of the unit, the unit is in high fire.

Discharge Control: When used in discharge control, the MUA board receives a call to heat from the intake sensor, the MUA board will modulate the discharge temperature until it hits the desired set point. The user can choose whether discharge heating is activated based on intake temperature, space temperature, either, both, or stat.

Space Control: When the space control option has been selected, there may be an HMI (that contains an internal temperature sensor) or a space thermistor. The user can choose whether the space heating is activated based on intake temperature, space temperature, either, both or stat.

Scan for DDC Application Guide

Analog Control/Direct Digital Control (DDC): A 0-10V DC or 0-20mA signal is sent to the MUA board from the building control system to regulate the heating output of the unit. Refer to [DDC Application Guide](#) for more information.



Modulating Gas System

The Modulating Gas System consists of an Intake Temp Sensor, a Discharge Temp Sensor, a Space Temp Sensor (only on space temperature control options), and modulating gas valve(s). The intake air sensor, the space sensor, or a combination of the two can be used to give a call for heat signal to the MUA board.

The MUA board uses a PID loop and checks the difference between the temperature sensor readings in order to modulate the heat appropriately.

- For kitchen MUA heating applications, intake air set point should be set at 45°F, whereas the discharge set point should be set at 55°F. The defaults may be adjusted per field conditions.
- For all other applications, the set point should be set appropriately based on end-user preferences and on-site conditions.

High Temperature Limit

One of the backup safety devices is the high-temperature limit lockout. This temperature sensor measures the temperature inside the unit, downstream of the burner. If the factory-set temperature of °F is exceeded, it will signal the FSC to turn off the burner. This requires a manual reset of the high-temperature limit. Refer to **“Resetting Unit” on page 152.**

Flame Safety Control (FSC)

The Flame Safety Control (FSC) is present **only** to monitor the flame, **NOT** to control temperature.

The FSC uses a sensor mounted at the intake of the upper-most firing tube of the furnace to sense the existence of a flame. The FSC controls the opening of the solenoid gas valve, and the operation of the spark igniter to initiate a flame upon start-up. When there is a call for heat, the LED on the FSC is energized, indicating that the unit has power. Then, there is a one-minute pre-purge. The power vent blower on the furnace is sent to high speed to exhaust any gas in the Heat-exchanger/Control Cabinet that may be present before trial for ignition. As soon as the pre-purge has initiated, the FSC checks that airflow is sensed by the power vent airflow switch and that the High Limit and Roll-out switches are not tripped.

Upon successful sensing of induced power vent airflow, continuity of temperature limit, and roll-out switches, the FSC initiates a **15-second** ignition sequence. During this ignition sequence (**Figure 44**), the FSC opens the On/Off gas valve and allows gas to pass through to the gas manifold. At the same moment, the spark igniter begins to spark, causing the electrode on the burner to ignite the gas. This results in a flame at the lowest firing tube of the furnace. This immediately ignites the flow of gas in each succeeding firing tube moving vertically until the entire furnace is lit. When the sensor detects the flame at the intake of the uppermost firing tube, the FSC continues to power the On/Off gas valve until there is a loss of flame presence. This is the normal operating mode.

Figure 44 - Ignition Sequence

Interval Description	Initial Call for Heat	1 Min. Pre-Purge	15 Sec. Trial for Ignition	1 Min. Inter-Purge	15 Sec. Trial for Ignition	1 Min. Inter-Purge	15 Sec. Trial for Ignition	2 Min. Post-Purge	1 Hr Lockout	Repeat Cycle
Time (Min:Sec) (Non-Linear Scale)		0:00	1:00	1:15	2:15	2:30	3:30	3:45	5:45	End Cycle

Modulating Stage Sequence

The modulating stage operates differently than other On/Off staged furnaces. Instead of being “On” or “Off,” the gas flow to this furnace is modulated up and down to account for varying calls for heat during the unit’s operating period. In addition, the speed of its power vent blower is varied as the gas flow changes to maintain constant combustion efficiency over the entire firing range.

The modulating furnace power vent blower is controlled by an on-board speed controller, located on the MUA control board. Voltage to the motor is based on a **0-10V DC** signal. The output voltage (True RMS) to the motor varies non-linearly between **120V AC @ 10V DC** for high fire and **86.5V AC @ 0V DC** for low fire.

MUA Board and High Fire Start

The MUA board compares a difference between two sensor values and set points; or compares a **0-10V DC** or **0-20 mA** signal from an analog control to the modulating furnace. The signal is linearized such that input voltage is directly proportional to amount of gas being delivered to the modulating valve.

To ensure proper light-off in all conditions, the MUA board contains software that forces the modulating furnace to light at high-fire when that furnace’s main gas valve is first opened. There is a built-in timer that allows it to send a constant **10V DC** signal to the modulating gas valve, and power vent blower speed controller. This will force the furnace into high-fire for a period of **17-seconds** after the initial spark is sent by the FSC. After this forced high-fire light-off period has expired, the modulating furnace’s power vent blower and modulating gas valve will receive a modulating signal from the MUA board.

Re-Circulating Control Options

The ratio of outdoor to indoor air in the discharge supply air can be adjusted through the MUA board output. The board will output a **0-10V DC** signal to command the position of the damper. There are several options for controlling the position of this damper. Use the HMI panel to change options:

Factory Settings > Unit Options > Outdoor Air Config> Outdoor Air Ctrl

Powered Exhaust

The powered exhaust fan is located by the intake damper assembly and is designed to prevent the building from over pressurizing. When there is excessive static in the building's return ductwork, the powered exhaust fan will assist exhausting air directly outdoors to balance the building's internal pressure. The powered exhaust fan will actuate depending on the outdoor air configuration's settings and supply fan activation.

Outdoor Air Configuration

When Outdoor Air % or Schedule is selected, "Outdoor Air Deadband" will be active. This setting checks the delta T between outdoor and return air. If the difference between these two temperatures is less than or equal to the dead band setting (default setting is 5 degrees), the MUA board will not alter its output to the damper assembly.

Off - Outdoor air control from the control board will not output a signal. May be used when damper is controlled by a photohelic gauge or a Building Management System (BMS).

Manual - The fresh air dampers can be manually controlled from the HMI panel corresponding to a 0-10V DC output signal from the control board. This output voltage signal can be manually adjusted. This will allow the user to manually set the dampers to match the building ventilation requirements.

2 Position - The fresh air dampers can be controlled by a two-position switch (a field-supplied switching device) to select closed position or 100% open. The control board sends out a constant 10V DC signal to the actuator. The field supplied switch will break or make the signal from the control board to the outdoor air damper. When the switch is used to disconnect power (open the circuit), or if a power failure occurs, or if the control board is shut-off, the return air damper will open by spring return. If using a two-position switch, connect in series to the control board at connection A+ and D+.

Outdoor Air % - The dampers can be controlled from the HMI to position the dampers from 0% to 100% fresh air. The MUA board utilizes an internal algorithm to alter its 0-10V output to the damper assembly to maintain an exact outdoor air percentage.

100% OA - If this damper control is chosen, anytime the blower is running, the damper will be fully open. The board logic will send 10 volts to open the damper. When there is no call for the blower, the board logic will send 0 volts to close the damper.

Analog Control - When this is set to ON, the damper will modulate linearly between the min and max OA voltage for both occupied and unoccupied modes.

Pressure Control - Damper position will modulate to maintain building pressure. Building pressure below the set point will increase the amount of outdoor air supplied to increase pressure.

NOTE: When Scheduling is enabled, separate occupied and unoccupied set points will be available for outdoor air control settings.

Programmable Thermostat

The programmable thermostat can be set off the discharge sensor set point. This allows the unit to modulate for the programmed space set point. An example would be, if the discharge set point is set for 65°F, and the space calls for heat/cooling cycle, the unit will modulate to meet the discharge set point.

The thermostat can also work off blower mode. This setting will look at the intake air temperature. The unit will modulate to avoid bringing in too hot or too cold of air into the space.

Heating, Cooling, Defrost, and Reheat

Figure 45 - Heat Pump with Reheat Option

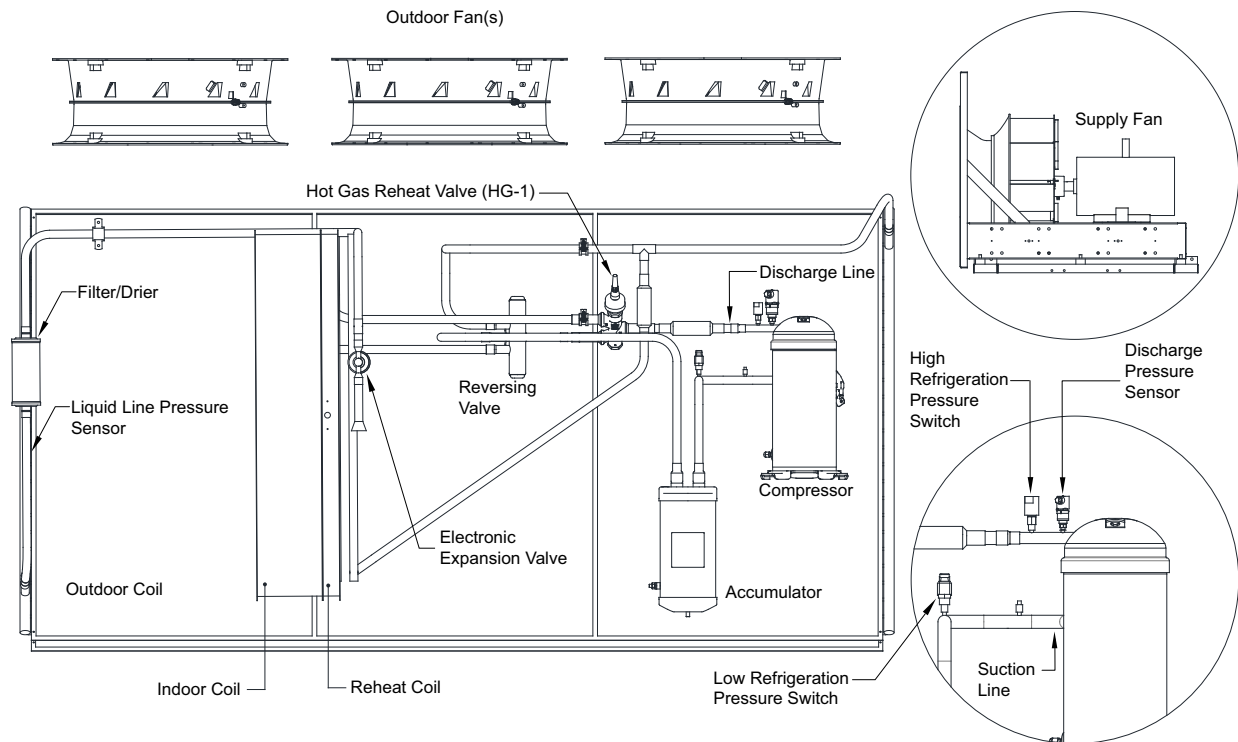

NOTE: Figure 45 is one example of many configurations offered.

Air velocity should be maintained between 200 and 550 fpm through the indoor coil.

Heating cycle (heat pump)

- In heating mode, the outdoor coil acts as the evaporator coil. When the thermostat calls for a heating sequence, the reversing valve is automatically powered. The compressor and outdoor fan start. The heating system is now in operation. Once the thermostat is satisfied, the system will shut down.
- The compressor pumps out high pressure refrigerant vapor. The vapor leaves the compressor, and then through the energized reversing valve.
- The refrigerant then flows through the indoor coil. Supply air removes heat from the refrigerant vapor, warming the indoor air and heating the building. When enough heat is removed, the vapor condenses into a high pressure liquid. The liquid temperature is slightly warmer than indoor air temperature. The liquid refrigerant then passes through an Electronic Expansion Valve (EEV), reducing its pressure and temperature, then passes through a filter/drier. The filter/drier adsorbs water and filters system contaminants.
- As the cool, low pressure liquid refrigerant enters the outdoor coil, it expands and absorbs heat from the outdoor air passing over the finned surface. Heat from the outdoor air causes the low pressure liquid to evaporate into a cool vapor.
- The cold refrigerant vapor passes through the outdoor vapor line to the reversing valve. The reversing valve directs refrigerant into the accumulator. The accumulator holds a liquid refrigerant and oil mixture, and controls flow back to the compressor. The liquid refrigerant and oil mixture are metered back to the compressor through a small orifice near the bottom of the accumulator.
- The refrigerant vapor passes through the suction line to the intake of the compressor. The cycle then repeats.

Cooling cycle

Figure 46 is a basic representation of the cooling cycle.

- When the cooling sequence is initiated, the compressor and outdoor fan start. The cooling system is now in operation. Once the thermostat is satisfied, the system will shut down.
- The compressor pumps out high pressure refrigerant vapor (discharge line). The vapor leaves the compressor. If the unit is a heat pump, the vapor will pass through the de-energized reversing valve.
- The vapor flows through the discharge line to the outdoor coil. Air from the outdoor fan removes heat from the refrigerant vapor. When enough heat is removed, the vapor condenses into a high pressure liquid. The liquid temperature is slightly warmer than ambient air temperature. This warm, high pressure liquid leaves the outdoor coil and flows through the copper refrigerant line. The liquid passes through a filter/drier. The filter/drier adsorbs water and filters system contaminants.
- At the end of the line, the refrigerant passes through an Electronic Expansion Valve (EEV), reducing its pressure and temperature.
- As the liquid, under reduced pressure, enters the indoor coil, it expands and absorbs heat from the indoor air passing over the finned surface. Heat from the indoor air, causes the low pressure liquid to evaporate, and cools the indoor air. The refrigerant is now a cool vapor.
- Refrigerant vapor passes through the insulated vapor line. If the unit is a heat pump, a reversing valve will direct refrigerant into the accumulator. The accumulator controls liquid refrigerant and refrigerant oil flow back to the compressor. Refrigerant vapor passes through the suction line to the compressor. The cycle then repeats.

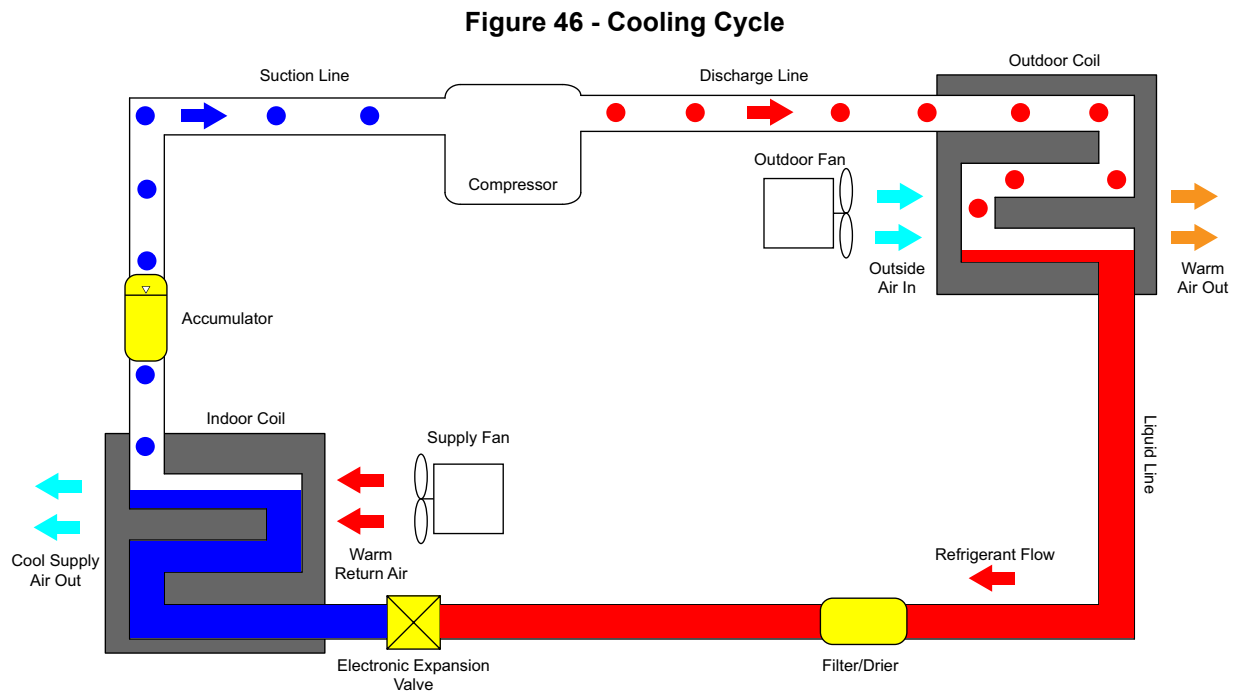

Defrost cycle (heat pump)

- In heating mode, the outdoor (condensing) coil acts as the evaporator coil. Moisture from the outside air condenses on the outside coil, and normally runs off. During the colder part of the heating season, this moisture freezes. This frozen moisture blocks air movement through the coil. A defrost cycle needs to be run to remove the frost.
- The defrost control detects the buildup of ice on the outdoor coil. The reversing valve will direct hot gas from the compressor to the outdoor coil. This starts the defrost process.
- The outdoor fan stops to prevent cold air from being passed onto the outdoor coil while hot refrigerant is in the outdoor coil.
- When the defrost control has detected the ice has melted, the defrost mode will end. The reversing valve shifts to the heating position. Hot refrigerant gas is then sent to the indoor coil. The outdoor fan operates, and the unit is now in normal heating mode.

Reheat cycle (cooling only)

- During the reheat cycle, a portion of the hot gas from the compressor enters the reheat coil and then is fed into the discharge line to the outdoor coil.
- The air is cooled and dehumidified as it flows across the indoor coil. It is then reheated by the reheat coil to lower the relative humidity.

Reversing valve for heating/cooling (heat pump)

When the unit is set up to run as a heat pump, the reversing valve is activated before the compressor starts. The reversing valve will de-energize if there is a call for cooling. Refer to **Figure 47** for details.

- When the internal valve is de-energized (down), the unit will be in cooling mode.
- When the internal valve is energized (up), the unit will be in heating mode.

Figure 47 - Reversing Valve

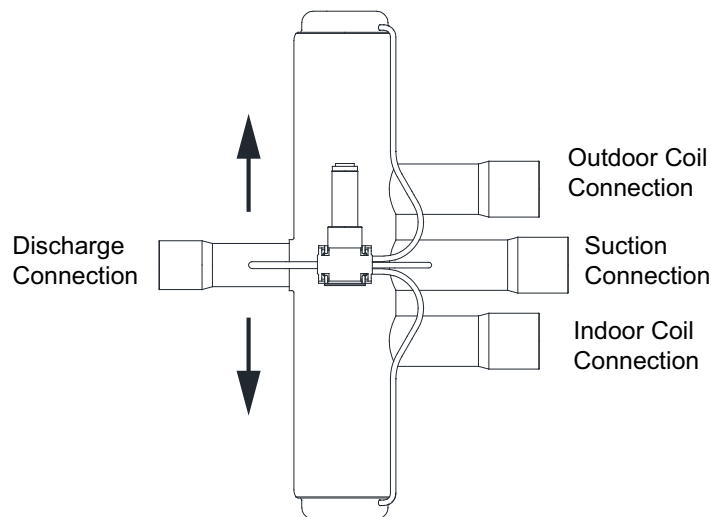

Economizer

Economizer type sets the type of economizer logic that will be used. This feature will control the economizer using a **0-10V DC** signal output on the MUA board. The table below shows option selections and definitions.

Use the HMI to select Economizer type. Go to **Factory Settings > Unit Options > Outdoor Air Config > Economizer**.

Table 15 - Economizer Options

Option	Definition
Fixed Dry Bulb	The economizer will modulate open if the outdoor air temperature is less than the economizer temperature set point. The modulation occurs from the current damper position to fully open over a specific temperature range (determined by the economizer temperature band value).
Differential Dry Bulb	The economizer will modulate open if the outdoor air temperature is less than the return air temperature. The modulation occurs from the current damper position to fully open over a specific temperature range (determined by the economizer temperature band value).
Fixed Total	The economizer will modulate open from the current position if the outdoor air dew point temperature is less than the economizer dew point set point, and the outdoor dry bulb temperature is less than the economizer temperature set point. The dew point set point is calculated using the economizer temperature and humidity set points. The modulation occurs from the current damper position to fully open over a specific dew point temperature band.
Differential Total	The economizer will modulate open from the current position if the outdoor air wet bulb temperature is less than the economizer dew point set point, and the outdoor dry bulb temperature is less than the economizer temperature set point. If the return dew point is less than the dew point set point, the unit will use the return dew point as the beginning of the modulation band. The modulation occurs from the current damper position to fully open over a specific dew point temperature band.

Disable Cooling

This allows the user to set the Outdoor Air (OA) percentage through the damper assembly (**Figure 48**) when mechanical cooling is disabled.

Refer to **“Psychrometric Chart” on page 102** for economizer operation and logic.

Figure 48 - Damper Assembly

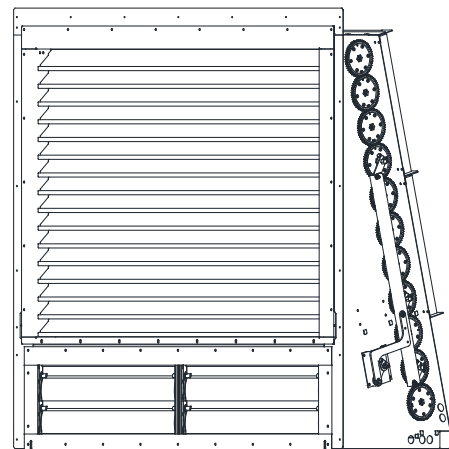

Psychrometric Chart

Fixed Dry Bulb Economizer

Psychrometric Chart

Normal Temperature

I-P Units

Sea Level

Barometric Pressure: 29.921 Inches of HG

- Set Point Temp
- Economizer Band
- Low Limit Temp

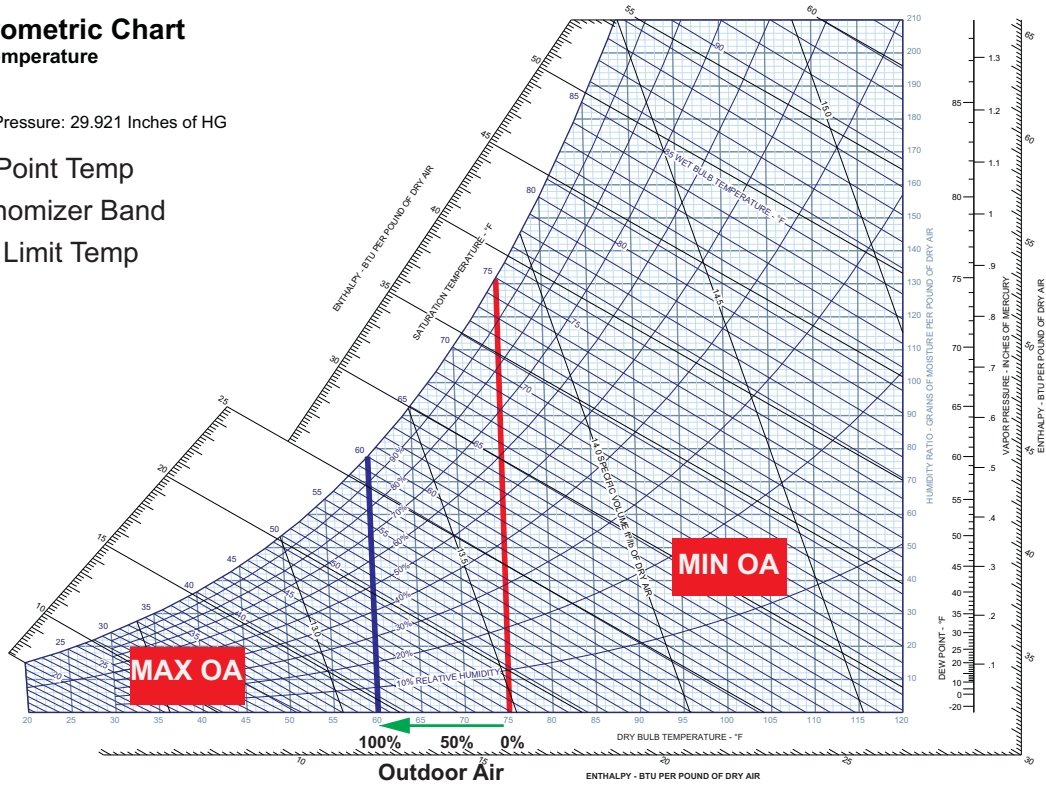

Differential Dry Bulb Economizer

Psychrometric Chart

Normal Temperature

I-P Units

Sea Level

Barometric Pressure: 29.921 Inches of HG

- Set Point Temp
- Economizer Band
- Low Limit Temp
- Return Temp

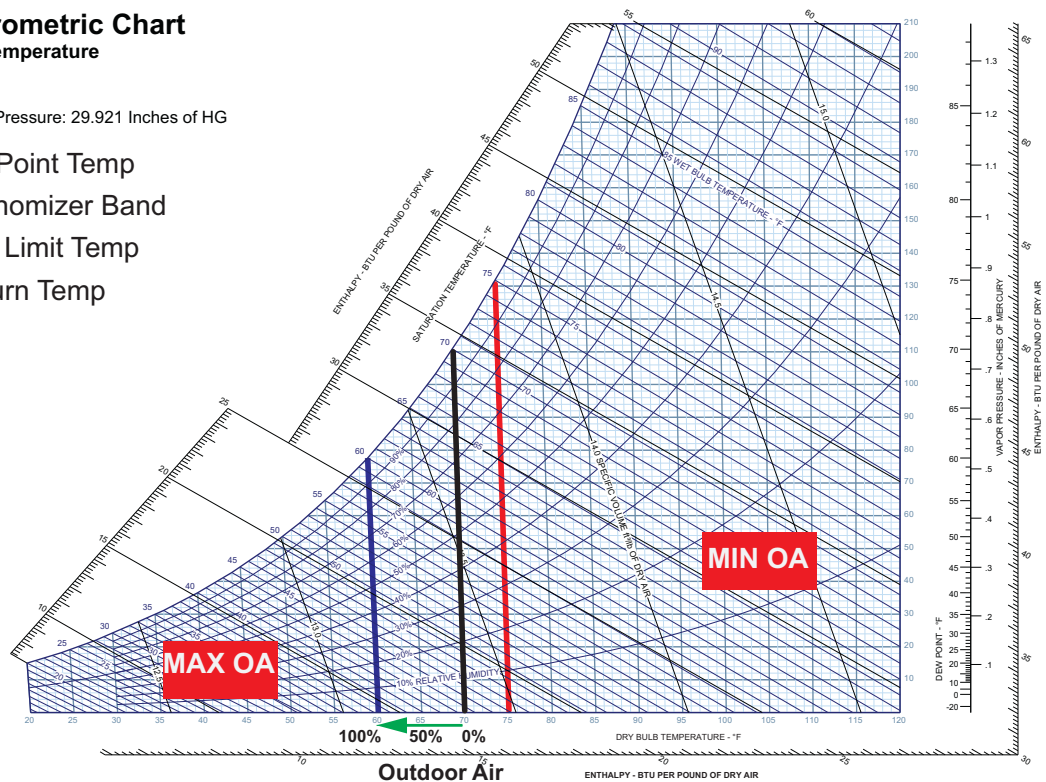

Fixed Total Economizer

Psychrometric Chart

Normal Temperature

I-P Units

Sea Level

Barometric Pressure: 29.921 Inches of HG

- Set Point Temp
- Economizer Band
- Low Limit DP
- Set Point %RH
- High Limit DP

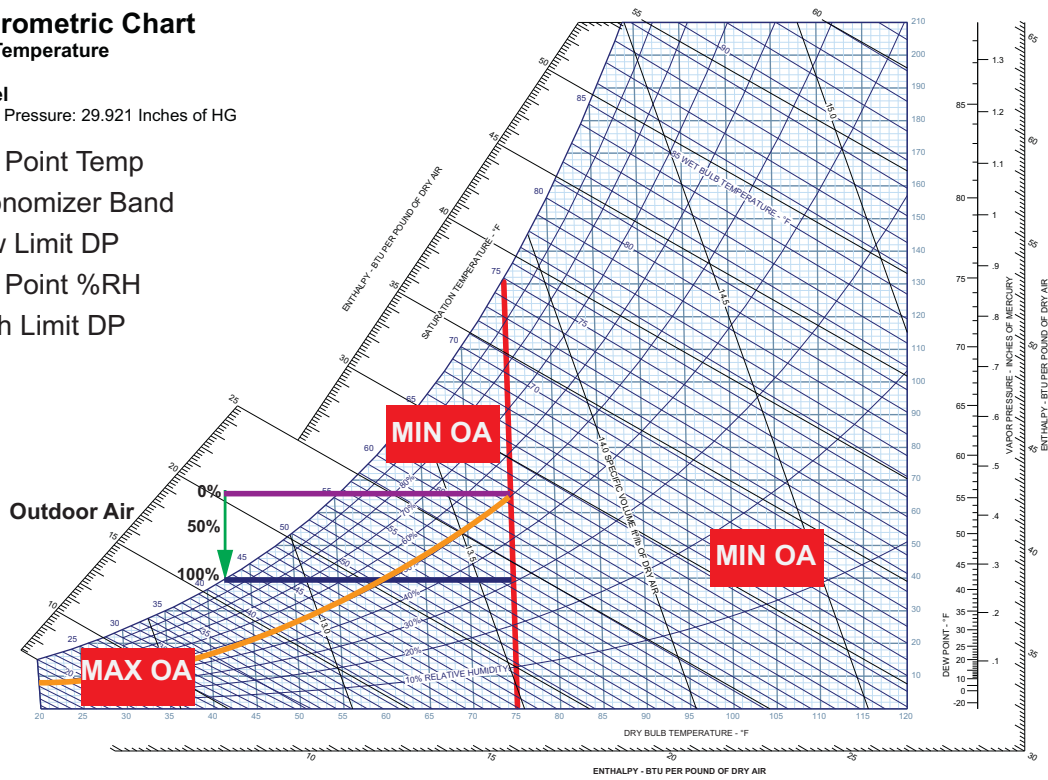

Differential Total Economizer

Psychrometric Chart

Normal Temperature

I-P Units

Sea Level

Barometric Pressure: 29.921 Inches of HG

- Set Point Temp
- Economizer Band
- Low Limit DP
- Set Point %RH
- High Limit DP
- Return DP

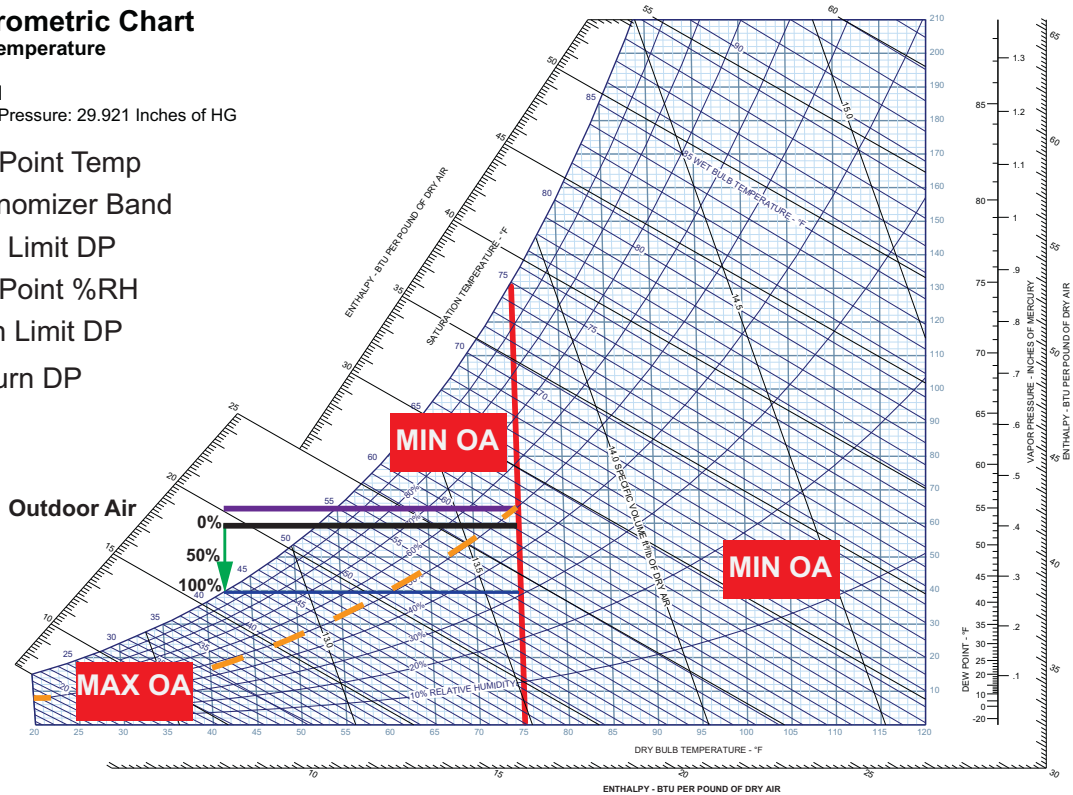

Hydronic Heating/Cooling (Optional)

The Hydronic Heating Coil is located below the blower with field-piped connections in the bottom of the electrical cabinet. The Inlet and Outlet are both labeled accordingly, and there are factory installed ball valves and drains for maintenance.

The Chilled Water Coil is located upstream of the blower with field-piped connections located in the chilled water compartment. The Inlet and Outlet are both labeled accordingly.

Refer to **Figure 49** for Hot Water and Chilled Water connection locations.

It is important to prevent the water from freezing to protect the coil and pipes from cracking. If the cooling circuit is not in use during winter, the water can be drained from the coil and the piping. There are drains located at the bottom of each coil and vents located at the top of each coil. Drains are also located near the ball valves. Glycol can also be used in the water to lower the freezing point. Refer to **Table 16** for glycol percentage to freezing point.

Figure 49 - Hydronic Connections

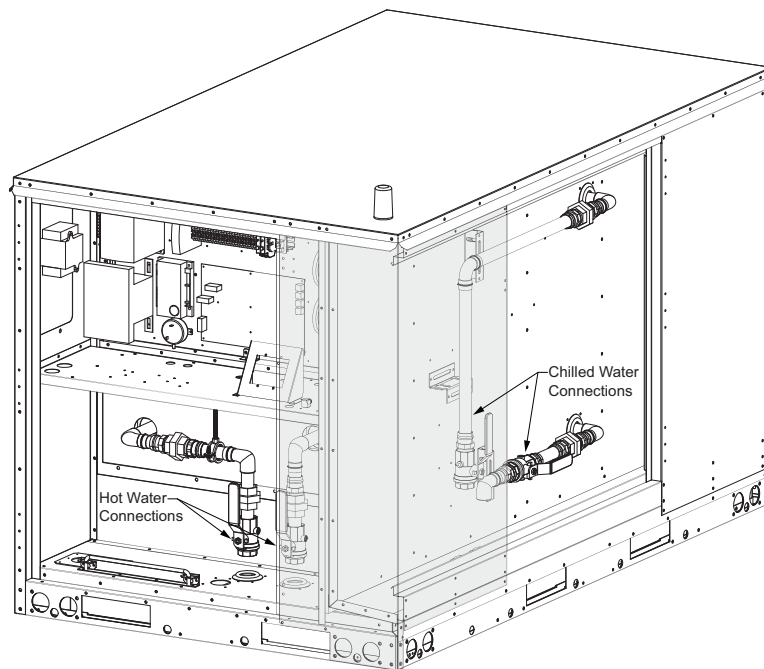

Table 16 - Glycol Percentage vs. Freezing Point

% Ethylene Glycol by Volume	Freezing Point Temperature (°F)
0	32
10	25
20	16
30	3
40	-13
50	-34
60	-55

% Propylene Glycol by Volume	Freezing Point Temperature (°F)
0	32
10	26
20	19
30	8
40	-7
50	-28
60	-60

Energy Recovery (Optional)

The Energy Recovery (Enthalpy) Wheel is assembled and installed from the factory. Minimal maintenance will provide years of trouble-free service.

If the unit is equipped with the optional enthalpy wheel, energy recovery is provided by pulling outside air across half of the wheel and moving exhaust air across the other half. Latent heat and sensible heat are moved from the hotter and moist exhaust air to the colder and dry outside air during winter conditions. Latent heat and sensible heat are transferred from the hotter and moist outside air to the cooler and dry exhaust air during summer conditions. Enthalpy control comprises of starting and stopping the exhaust fan, modulating the speed of the exhaust fan, starting and stopping the enthalpy wheel, and optionally controlling the speed of the enthalpy wheel. If required by outdoor air conditions, the outdoor damper is controlled in the normal manner. **Figure 50** provides details for components associated with the enthalpy wheel.

Figure 50 - Energy Recovery Wheel Overview

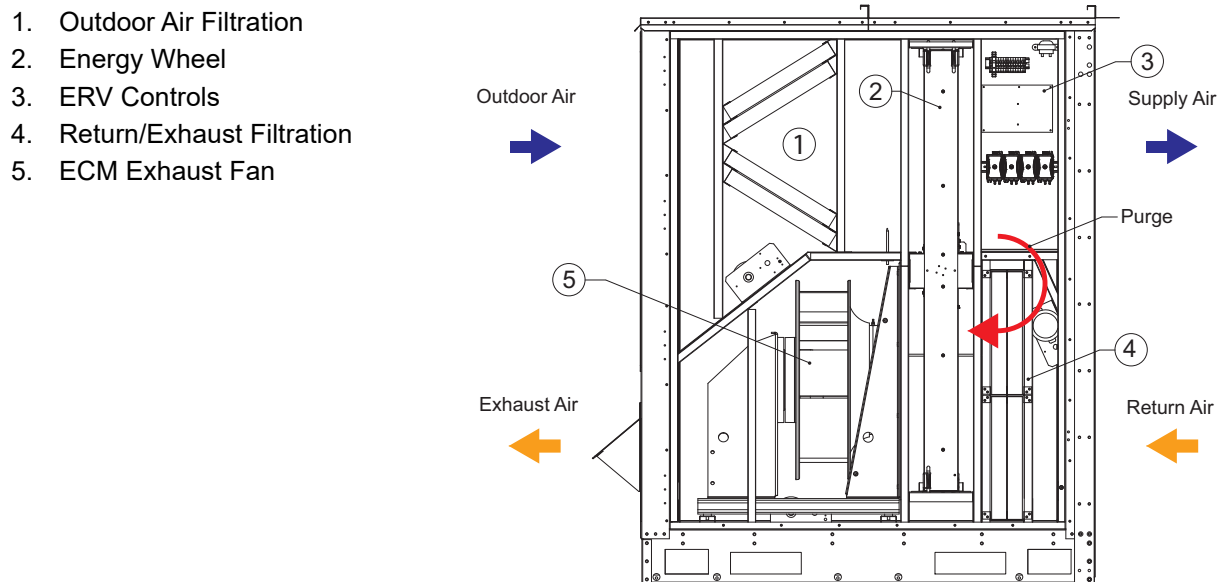

Purge and Pressurization

Pressurization is critical to minimize crossover from exhaust to supply and to allow the purge to operate properly. Move the adjustable purge plate (**Figure 51**) up to increase purge and minimize crossover.

Figure 51 - Purge Details

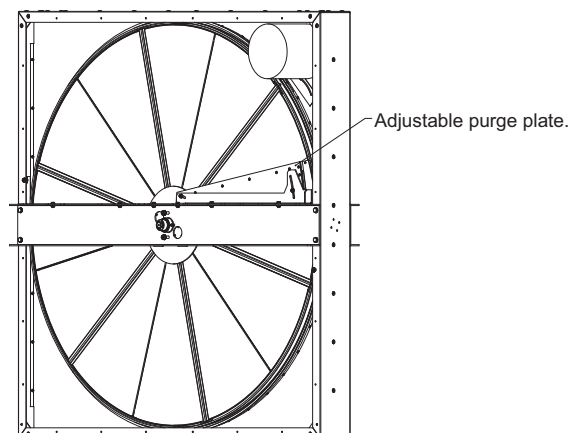

Drive Motor

The enthalpy wheel comes standard with a variable speed drive motor, which is pre-wired to turn in the proper direction. The motor can adjust speed to lower the enthalpy's wheel capacity during frosting conditions. This lowered capacity allows the wheel to recover energy still while preventing frosting. During non-frosting conditions, the modulation of the wheel allows enhanced capacity control of wheel for greater turn-down and more precise discharge control.

Frost Protection (Optional)

Figure 52 illustrates frost prevention conditions. During extremely cold winter conditions, the wheel can frost overdue to the moisture content of the return/exhaust air. A frozen wheel will increase static pressure and reduce efficiency of the wheel. If the wheel fully freezes, the host unit can be starved of supply air. To avoid this situation, the recovery wheel comes standard with a variable speed motor that modulates down during frosting conditions.

Figure 52 - Frost Prevention Psychrometric Chart

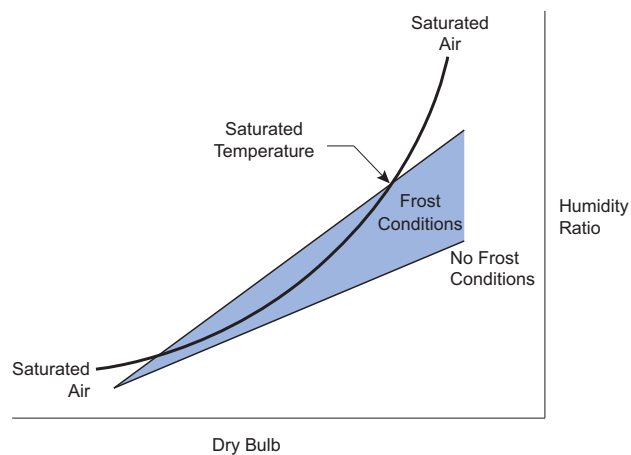

Variable Speed Frost Prevention

When there is a threat of frost on the enthalpy wheel, the wheel is slowed down so that less enthalpy transfer occurs, and frosting of the wheel is avoided. Frosting can occur on the enthalpy wheel when the exhaust air leaving the wheel is saturated. This condition occurs when the energy transfer and saturated air lines intersect on a psychrometric chart, and it does not occur when these two lines do not intersect.

Energy Recovery Exhaust Hoods

Units with the optional energy recovery module have an exhaust hood. Each hood is factory installed over the barometric relief, allowing the unit to function in adverse weather without the risk of water/debris infiltration.

Exhaust Fan

Unit utilizes an integral ECM exhaust fan that features various control modes to optimize energy transfer and ensure proper air movement. Exhaust cabinet features barometric relief that seals when the exhaust fan is not powered. This will allow for return air to be utilized when the ERV is off.

Slide-Out Wheel

The wheel can be pulled out to facilitate cleaning and servicing. Power wires for the wheel will need to be unfastened from the lid of the module to allow the full range of motion necessary to service the wheel.

Field Installation of Large ERVs

Due to their larger size, all size 4 ERVs are shipped loose and must be mounted and wired in the field. This section and **Figure 53** through **Figure 56** on page 108 cover the install and wiring process for large ERVs. These larger ERVs will have hardware bags and gasket rolls placed inside before shipping. Such units should have the gasket applied to the mating side as shown in **Figure 53**.

If the unit is not gasketed already, add gasketing to the marked lines on the mounting side of the ERV before installation (**Figure 53**). Ensure that any joints between gasket strips are silicone to guarantee water cannot travel between the strips.

Figure 53 - ERV Gasket Outline

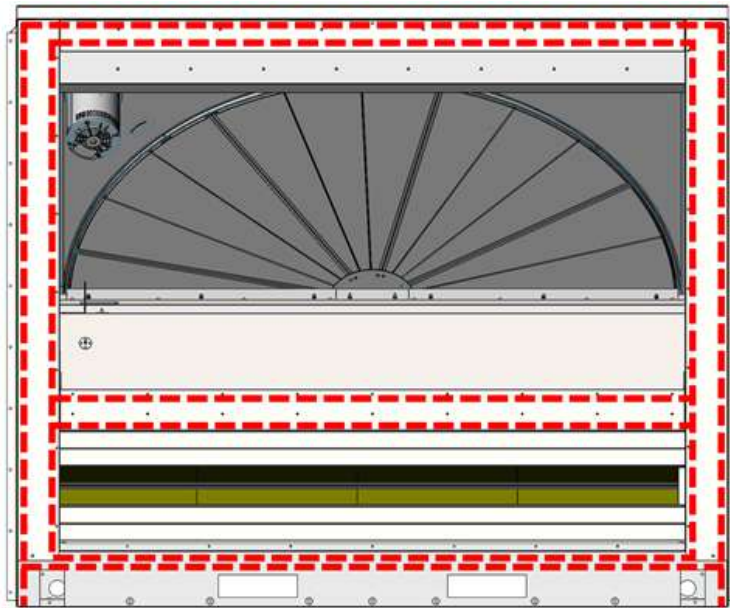

Next, align the ERV with the RTU unit. Ensure that the marked brackets (**Figure 54**) are aligned and pushed as close together as possible.

Figure 54 - ERV Mating Profile

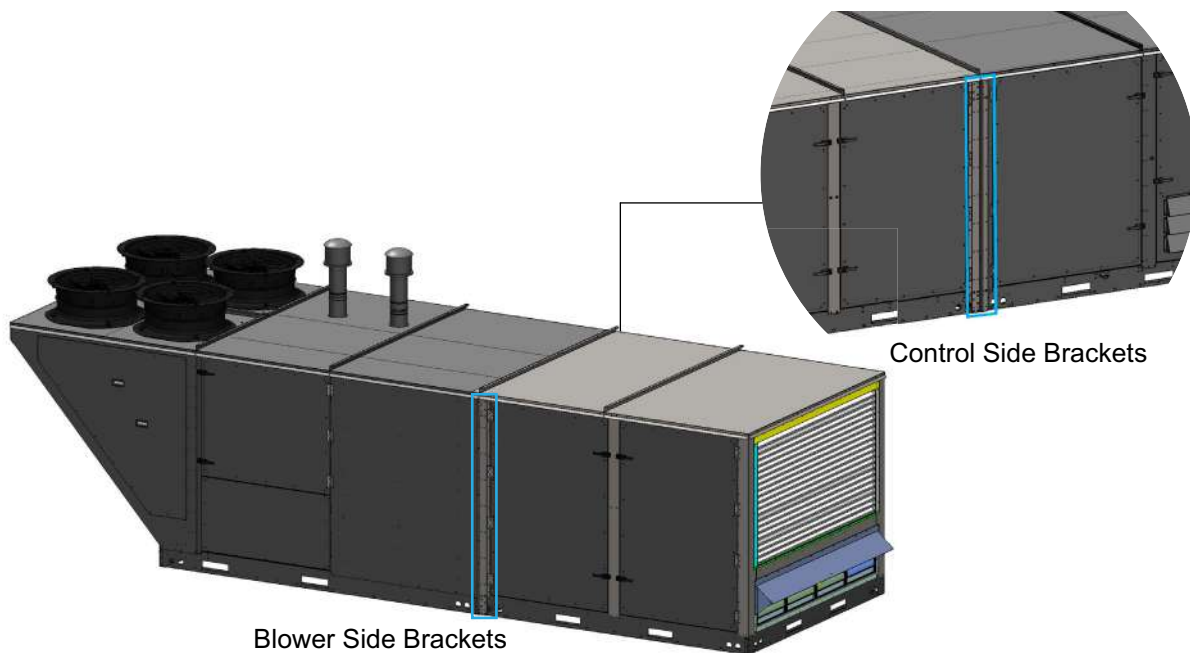

After the units are positioned correctly, push the bolts through the aligned holes on the side mounting brackets and hand tighten the nuts on the other side. **BOTH SIDES MUST HAVE THE BOLTS INSTALLED AND HAND TIGHTENED.**

Working around the unit (from side to side), uniformly tighten the bolts to bring the modules together. Ensure the gasket between the two mating surfaces are compressed. **FAILURE TO DO SO CAN RESULT IN POOR SEALING AND WARPED METAL ON THE UNIT.**

Once the ERV has been mounted tight against the RTU, place the top mating bracket over the exposed raised flange on the ERV lid (**Figure 55**). Liberally apply silicone to all points of contact between the mating bracket and lids. Rivet the mating bracket to the raised flange of the ERV lid. Use 1-1/2" (max) rubber-washer self-tapping screws to attach to the lid of the RTU.

Figure 55 - ERV Top Lid

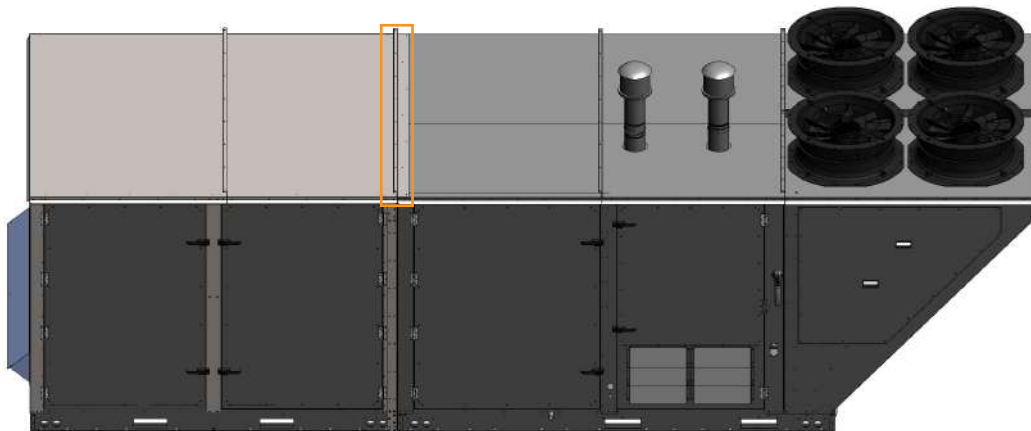

With the ERV fully attached, the power and communication wires must be connected (**Figure 56**). **MAKE SURE THE UNIT HAS NO POWER TO ITS MAIN DISCONNECT BEFORE CONTINUING.**

The ERV will have junction boxes in the lower right of the module relative to the control panel. The largest junction box will have a set of terminal blocks for incoming power. Two cable bundles that require field wiring will be spooled and stored in the return opening of the RTU. The larger junction box will have terminal blocks for incoming power for the ERV module. The smaller junction box will have a CAT5 cable with a coupler. Connect the supplied CAT5 cable from the RTU to the coupler. With this done, restore power to the RTU and verify the ERV powers up and can communicate with the main board in the RTU unit.

Figure 56 - ERV Electrical Connections

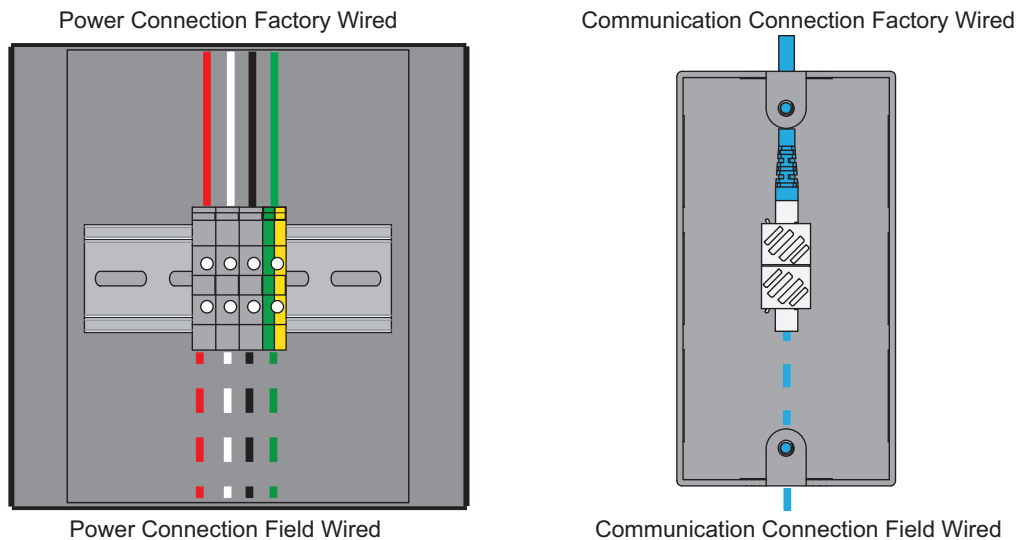

SERVICE INFORMATION

WARNING: Technicians must be certified by an EPA-approved training and certification program to service any HVAC equipment, regardless of the refrigerant.

Basic Service

NOTE: Always wear gloves and eye protection when working with refrigerant.

NOTE: Purge lines before connecting to service ports.

Figure 57 - Refrigeration Service Tools and Service Port Locations

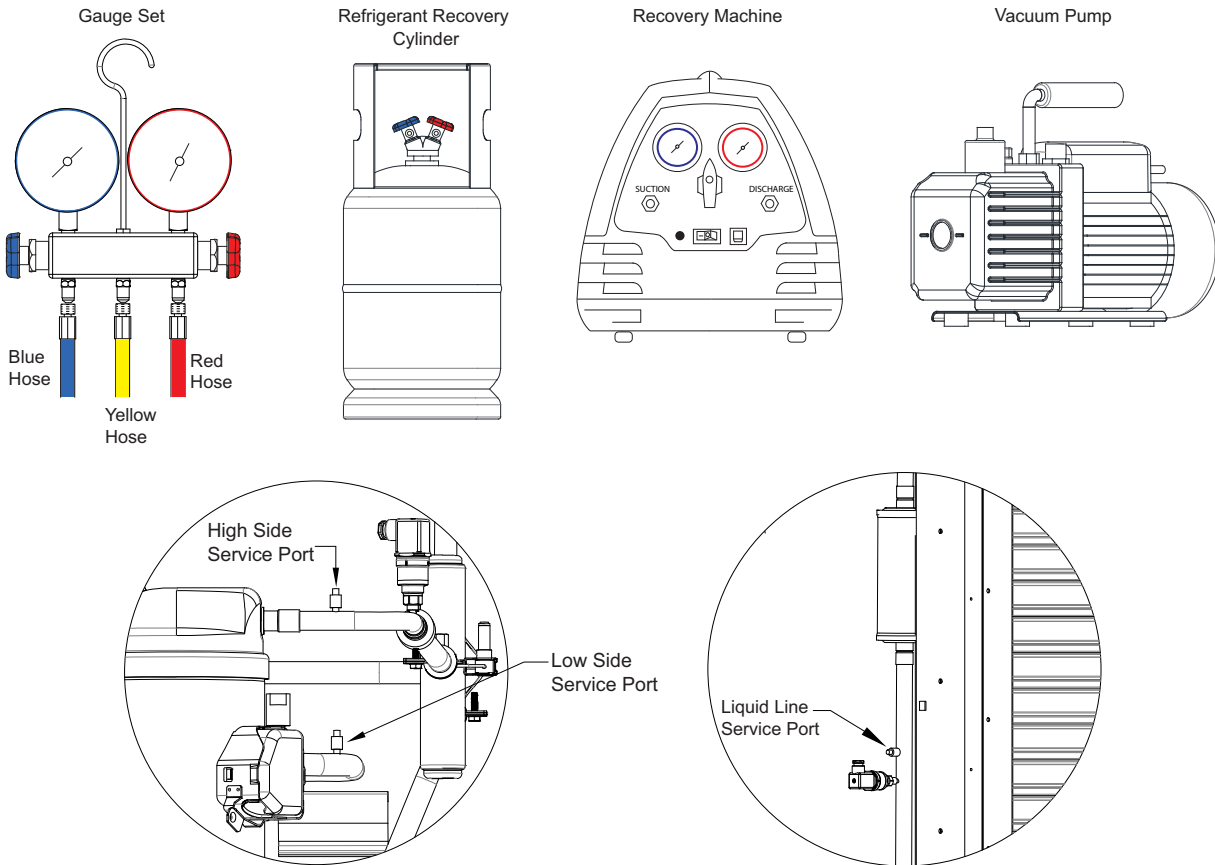

Monitoring the A/C System

NOTE: Do not add or remove refrigerant based on the impulse to achieve a subjective subcooling value. Refer to “Superheat and Subcooling” on page 134 for more information.

Monitoring with HMI

The HMI can monitor the A/C temperature and pressure readings through the service function menu. Enter HMI menu function by pressing the top two buttons simultaneously. Navigate to **Service (Password 1234) > Inputs > Refridge Diag.**

The Refridge Diag menu will display the following:

- Discharge Pressure (DSCHRG PS)
- Discharge Condensing Temperature (DCH CON TMP)
- Suction Pressure (SUCTION PS)
- Suction Saturation Temperature (SUC SAT TMP)
- Suction Line Temp (SUC LIN TMP)
- Superheat Temperature
- EEV Position Percentage
- Compressor Hertz
- PWM Rate Percentage
- Oil Voltage - Yes/No

Monitoring with Gauge Set

1. Close the high side hand valve (red) and low side hand valve (blue).
2. Connect vacuum rated manifold service hoses, refer to **Figure 57 on page 109.**
 - Red service hose to the high side service port.
 - Blue service hose to the low side service port.
 - Verify the yellow service hose is capped when not connected to a refrigerant tank, recovery tank, or vacuum pump.
3. Connect a standard pressure gauge set to the liquid line service port located on the outdoor coil, see **Figure 57.**
4. Start the system.
5. If the service hoses have a manual turn valve, open the valve. Monitor the following:
 - The low side and high side gauges.
 - The superheat reading should be 20°F.
6. Refer to **Table 17 on page 134** and **Figure 59 on page 135** to determine subcool. Compressor must be running at 100%, and condenser fan temperature must be 110°F.
NOTE: subcool readings will vary based on ambient and condensing fan temperatures.
7. Determining the readings:
 - If the readings are correct, close the gauge set and shut down the system. Disconnect the gauge set, refer to **“Removing Manifold Gauge Set” on page 114.**
 - If the readings are incorrect, follow the **“System Troubleshooting Chart” on page 115** to locate and repair the problem.

Recovering Refrigerant from the System

1. Connect vacuum rated manifold service hoses, refer to **Figure 57 on page 109**:
 - Red service hose to the high side service port.
 - Blue service hose to the low side service port.
 - Connect the yellow service hose to the inlet port of the recovery machine.
 - Connect a hose from the discharge port of the recovery machine to the recovery tank.
2. Purge all hoses of non-condensables before starting the system.
3. Place the system in 'Evacuation Mode'. Enter HMI menu function by pressing the top two buttons simultaneously. Navigate to **Service > Test Menu > Evacuation Mode > Enable**.
4. When the system is in 'Evacuation mode', the EEV and reheat valve (if applicable) will open and allow full access to the system via the high and low side service ports. Ensure the compressor does not run by pressing 'OFF/Reset' on the compressor VFD HMI.
5. Open the connected valve on the recovery tank.
6. Turn the recovery unit on. Open the low side and high side hand valves.
7. Monitor the gauge set until all refrigerant has been recovered and the system is under a proper vacuum.

IMPORTANT!: Units should NOT be dye tested for leaks on the refrigerant system as it will void compressor warranty.

Nitrogen Purging

Whenever brazing will be performed in the system, flowing nitrogen through the system is required. This should be done when unsweating connections or brazing new components in the system. Remove Schrader core from the inlet and outlet path for full flow and minimize back-pressure. This step is critical to prevent oxidation and protect the system from contaminants.

Pressure Testing

Anytime repairs are made, use dry nitrogen to verify there are no leaks in the system. Connect the dry nitrogen tank to the high and low service ports, ensuring the entire system will be pressurized. Pressurize the system to 350-400 PSI. Use soap bubbles or another liquid leak solvent to check for leaks. Check the system for approximately 15 minutes. For instructions on how to evacuate the system, refer to "**Evacuating the System**".

- If there are leaks, evacuate the nitrogen from the system. Repair as necessary.
- If there are no leaks, evacuate the nitrogen from the system.

Evacuating the System

1. Connect vacuum rated manifold service hoses, refer to **Figure 57 on page 109**:
 - Red service hose to the high side service port.
 - Blue service hose to the low side service port.
 - Connect the yellow service hose to the vacuum pump.
2. Connect a micron gauge to the liquid line service port located on the outdoor coil, refer to **Figure 57**.
3. Place the system in 'Evacuation Mode'. Enter HMI menu function by pressing the top two buttons simultaneously. Navigate to **Service > Test Menu > Evacuation Mode > Enable**.
4. When the system is in 'Evacuation mode', the EEV and reheat valve (if applicable) will open and allow full access to the system via the high and low side service ports. Ensure the compressor does not run by pressing 'OFF/Reset' on the compressor VFD HMI.
5. Open the high side hand valve (red) and low side hand valve (blue). Start the vacuum pump.
6. Pump the system down until the micron gauge reads 500 microns.
7. Close off the valve to the vacuum pump. Turn the pump off.
8. Monitor the micron gauge for twenty minutes. Make sure it does not rise above 1000 microns.
 - If the reading goes above 1000 microns in less than twenty minutes, there is a leak or moisture in the system. Determine the issue and repair.
 - If the reading stays below 1000 microns, close all valves on the manifold gauge set.
9. Charge the system, refer to "**Charging an Empty System**" on page 113.

NOTE: To prevent trapping liquid refrigerant in the manifold gauge set, make sure the gauge set is brought to suction pressure before disconnecting.

Charging an Empty System

1. Connect the manifold service hoses, refer to **Figure 57 on page 109**:
 - Blue service hose to the liquid side service port.
 - Connect the yellow service hose to refrigerant source.
2. Connect a temperature clamp near the liquid line service port located on the outdoor coil, refer to **Figure 57**.
3. Place the system in 'Evacuation Mode'. Enter HMI menu function by pressing the top two buttons simultaneously. Go to **Service > Test Menu > Evacuation Mode > Enable**.
4. When the system is in 'Evacuation mode', the EEV and reheat valve (if applicable) will open and allow full access to the system via the high side, low side, and liquid line service ports.
5. Ensure the compressor does not run by pressing 'OFF/Reset' on the compressor VFD HMI.
6. Open the valve on the refrigerant source.
7. Open the low side hand valve (blue) on the manifold set.

NOTE: Unit should be charged with liquid refrigerant.

8. Once the unit has at least 50% of the charge from the unit label, close the valve on the refrigerant source and the low side hand valve (blue) on the manifold set. Abort 'Evacuation Mode.'
9. Remove blue service hose from the liquid line service port.
10. Connect blue service hose to the low side service port. Verify the yellow service hose is connected to the manifold and refrigerant source.
11. Open the valve on the refrigerant source.
12. Check the compressor's oil level before starting unit. Refer to "**Compressor Information**" on **page 57** for compressor models and oil type information.
13. Verify the unit is in an idle state (it should not be in cooling, heating, reheat, or blower only modes).
 - Occupied scheduling must be disabled. **Go to Factory Settings > Occupancy Config > Scheduling > Off.**
 - Turn on the cooling system through the service test menu. Go to **Service > Test Menu > Test Cool/HP > Select unit's cooling type.**
 - Set the compressor to run at maximum speed and verify reheat voltage is set to 0V.
 - The blower will be off and the damper will be closed when in an idle state. Adjust the components as needed.
 - Adjust condensing fans so that the condensing coil maintains a 110°F liquid saturation temperature.
14. To prevent damage to the compressor, do not open the hand valve all the way. Crack open the low side hand valve (blue) on the manifold set.
15. Continue charging the system until the following conditions are met:
 - Refer to **Table 17 on page 134** and **Figure 59 on page 135** to determine subcool.
 - Compressor must be running at 100%, and condenser fan temperature must be 110°F.

NOTE: Subcool readings will vary based on ambient and condensing fan temperatures.

- The superheat reading should be 20°F.
 - To monitor subcool, go to **Service > Test Menu > Test Cooling/HP > State > Cool > Cond Mode > Auto.**
 - Monitor the readings in the test menu screen.
16. Close the low side hand valve (blue). Monitor the gauge set, and determine if the system is operating properly.

NOTE: Once the unit is back to full operation, verify any altered settings (i.e. Scheduling) are changed back to their last set configuration.

Charging System Low on Refrigerant

NOTE: Do not add or remove refrigerant based on the impulse to achieve a subjective subcooling value. Refer to “Superheat and Subcooling” on page 134 for more information.

1. To add refrigerant with system running, open the low side hand valve (blue).
2. Start the unit. Verify the unit is in an idle state (it should not be in cooling, heating, reheat, or blower only modes). Occupied scheduling must be disabled.
3. Navigate to **Service > Test Menu > State > Cool/HP** to activate system test. Once the test is active, you may monitor and adjust settings.
 - Set the compressor to run at maximum speed.
 - Adjust condensing fans, and monitor the condensing coil maintains a 110°F temperature.
 - Verify reheat voltage is set to 0V.
4. Monitor the system until the following conditions are met:
 - Refer to **Table 17 on page 134** and **Figure 59 on page 135** to determine subcool.
 - Compressor must be running at 100%, and condenser fan temperature must be 110°F.

NOTE: Subcool readings will vary based on ambient and condensing fan temperatures.

- The superheat reading should be 20°F.
 - To monitor subcool, set Cond Mode to Auto. Navigate to **Service > Test Menu > Test Cooling/HP > State > Cool > Cond Mode > Auto**.
 - Monitor the readings through the test menu screen.
5. Check compressor oil level after a repair. Refer to **“Compressor Information” on page 57** for compressor models and oil type information.

Removing Manifold Gauge Set

1. Make sure the hand valves are closed.
2. Make sure the refrigerant source is closed / the vacuum pump is not running.
3. Disconnect all hoses from the service valve ports.
4. Install the service port caps. Tighten by hand.

TROUBLESHOOTING

The following tables and information list possible causes and corrective actions for possible problems. Review this section prior to consulting technical support.

System Troubleshooting Chart

Problem	Potential Cause	Corrective Action
Unit will not start	Power failure	Check voltage to the unit.
		Check the disconnect switch.
		Check the circuit breaker.
		Check the hot, neutral, and ground wiring.
Unit On - HMI Off	Power Issue	Check connector J13 is properly connected.
		Check wiring from HMI to connector J13.
		Verify the circuit breaker (CB-01) is On.
System operates continuously - poor cooling/heating (heat pump mode)	Shortage of refrigerant	Test for leaks. Add refrigerant.
	Restricted discharge line	Repair or replace as required.
	Dirty or clogged filters	Inspect filters. Clean or replace.
	Dirty indoor coil	Inspect coil. Clean the coil, refer to “Coil Cleaning Procedure” on page 150.
	Low airflow across indoor coil	Check blower speed, duct static pressure, filters.
	Compressor	Verify compressor modulates between Min to Max frequency.
	Electronic Expansion Valve (EEV)	Verify EEV position is 0% when not in heating or cooling under Refridge Diag. See “Monitoring the A/C System” on page 110. Check the correct EEV is installed. Refer to “Electronic Expansion Valve (EEV-1)” on page 146.
System operates – blows cold air in heat pump mode	Compressor	Verify compressor modulates between Min to Max frequency.
	Incorrect refrigerant	Refer to “Superheat and Subcooling” on page 134 to check parameters.
	Non-condensable in system	Recover the charge, evacuate the system. Recharge the system. Refer to “Basic Service” on page 109.
	Faulty reversing valve	Test reversing valve.
	Defrost control	Test defrost control.
System operates - blows cold air in gas heat mode	Gas supply issue	Refer to “Furnace Troubleshooting Chart” on page 133.
	Faulty gas train components.	
System runs – blows cold air in electric heat mode	Improper wiring	Check electrical wiring.
	Electric disconnect switch	Check electric heater disconnect switch
	Fuse in electric heater panel	Check fuses, replace is required.
	Airflow Switch	Check airflow switch and tubing at the MUA board.

HMI Fault Codes

Problem	Potential Cause	Corrective Action
Fire	A 120V AC signal was detected on the Fire input (terminal F).	Possible fire present.
		Check for voltage on terminal F. There should be no voltage.
		Verify connector J9 is secure. Pin 3 and 8 must be fully inserted.
		Check wiring. Repair broken or loose wiring connections.
		Replace fire detector if not operational.
Fire/Smoke (optional)	A signal was detected on the Smoke Detector input.	Check for voltage on terminal SD3.
		Verify the smoke detector is set up properly. Reset if required.
		Check wiring. Repair broken or loose wiring connections.
		Replace smoke detector if not operational.
Supply Ovld (optional)	The motor overload has tripped.	Check motor for debris.
Exhaust Ovld (optional)		Check contactor/motor wiring connections.
Master ROM CRC Aux ROM CRC		Verify motor rotation is correct.
Flame Lockout	The Flame Safety Control (FSC) verifies that airflow is sensed by the airflow sensor	Verify P108 is set properly. Check schematics for correct settings.
		Contact technical support.
Intake Firestat (optional)	The intake firestat temperature has exceeded its set point.	Faulty flame rod.
		Faulty FSC, replace FSC.
Discharge Firestat (optional)	The discharge firestat temperature has exceeded its set point.	Possible fire present.
		Check accuracy of sensor readings.
Freezestat (Optional)	The air-side discharge thermistor reported a value below the freezestat set-point for the duration of the freezestat timer when in fan only or heat state.	Verify high/low fire setting, refer to page 94 .
		Use the HMI to reset.
		Check accuracy of intake/discharge temperature sensor readings.
Overheat Stat (Optional)	The air-side discharge thermistor reported a value above the overheat set-point for the duration of the overheat timer.	Verify operation of reversing valve and heat pump.
		Use the HMI to reset.
		Check accuracy of intake/discharge temperature sensor readings.
		Verify cooling performance and refrigerant charge.
		Use the HMI to reset.

Problem	Potential Cause	Corrective Action
High Gas PS (optional)	The normally closed switch is open. The 24V AC input signal is no longer present at connector J13-pin 11.	If option is off, turn on in HMI.
		Verify incoming gas pressure.
		Check wiring. Repair broken or loose wiring connections.
		Verify high/low fire setting, refer to page 94 .
Low Gas PS (optional)	The normally closed switch is open. The 24V AC input signal is no longer present at connector J13-pin 10.	Refer to “ High Gas Pressure Switch (PS-03) ” on page 141 .
		If option is off, turn on in HMI.
		Verify incoming gas pressure.
		Check wiring. Repair broken or loose wiring connections.
CO Alarm	The detected CO level is above the sensor limit.	Verify high/low fire setting, refer to page 94 .
		Refer to “ Low Gas Pressure Switch (PS-04) ” on page 141 .
		Check for proper exhaust ventilation.
		Check wiring. Repair broken or loose wiring connections.
DX Float	The control board is receiving a signal from the evap drain pan float switch; indicating that the switch tripped because the drain pan filled with water.	Faulty CO detector, replace CO detector.
		Verify float switch is not stuck in tripped position.
		Make sure the pan drain is clear and water is draining.
		Check wiring. Repair broken or loose wiring connections.
Furnace Float	The control board is receiving a signal from the furnace condensation float switch; indicating that the high efficiency furnace was not draining.	Replace float switch if not operational.
		Refer to “ Furnace Condensation Drain ” on page 18 to check float.
		Verify pipe connections are not clogged.
		Verify the pipes are draining.
Supply VFD Comm	A communication error between the blower VFD and MUA board was detected.	Check wiring. Repair broken or loose wiring connections.
		Replace float switch if not operational.
		Verify supply VFD settings; P102 (min freq), P103 (max freq) on supply VFD match min/max blower freq in factory settings.
		Verify P410 on supply VFD is set to 21.
		Check CAT5 with a tester.

Problem	Potential Cause	Corrective Action
Door Interlock	No signal to control board from the door switch(es).	Verify door switches are wired properly, if required.
ERV Door Interlock		Check door interlock settings in HMI.
		Check doors for obstructions/alignment issues.
		Check ERV door interlock settings. Go to Factory Settings > ERV Config > Monitoring Sensors > Door Interlock .
DX VFD Comm	A communication error between the compressor VFD and MUA board was detected.	Check twisted shielded pair wiring. Verify compressor VFD parameters match schematics.
Aux Board MB Comm	A communication error between an auxiliary Modbus device and the MUA board was detected.	Check CAT5 wiring between MUA board and auxiliary board. Verify DIP switches are in the correct position for all control boards.
Supply Air Low	The onboard pressure reading was below the air proving setpoint; indicating low airflow.	Verify supply fan operation, refer to “Start-Up Procedure” on page 92 .
		Check damper operation.
		Check airflow switch and tubing at the MUA board.
Clogged Filters (optional)	The clogged filter input is active, indicating the pressure differential across the air filters was above the switch's field-adjustable setpoint.	Clean or replace filters.
		Refer to “Clogged Filter Switch (PS-10)” on page 137 .
Intake Stat Missing Dschrq Stat Missing Space Stat Missing OA Stat Missing Return Stat Missing Suction Line Missing Indoor Coil Missing 2nd Dschrq Stat Missing DX Dschrq Missing	The thermistor input is reading an excessively low temperature (high resistance/open circuit).	Check for faulty wiring, refer to “Temperature Sensor” on page 140 . Install and wire sensor.

Problem	Potential Cause	Corrective Action
Intake Stat Broken Dschrq Stat Broken Space Stat Broken OA Stat Broken Return Stat Broken Suction Line Broken Indoor Coil Broken 2nd Dschrq Stat Broken DX Dschrq Broken	The thermistor input is reading an excessively high temperature (low resistance/ short circuit).	Check for faulty wiring, refer to “ Temperature Sensor ” on page 140. Install and wire sensor.
Space HMI Missing	One of the HMIs in the system is not connected properly, or one of the settings is not properly set.	Verify that the “# of HMIs” is set correctly. Verify there is no damage to the HMI(s). Check for loose or damaged wiring to HMI(s). If space temperature is being utilized, make sure “HMI Averaging” is set to ‘On’ for all space HMIs.
RTC Temp Invalid Aux RTC Temp Invalid	Real-Time Clock (RTC) temperature sensor located on MUA board.	Verify there is no damage to the MUA board or the wiring to the MUA board. Contact technical support.
HMI 1 Temp Invalid HMI 2 Temp Invalid HMI 3 Temp Invalid HMI 4 Temp Invalid HMI 5 Temp Invalid	The unit HMI is unable to read temperature.	Verify control board dip switches match schematics. Verify HMI CAT5 cable. Verify the amount of HMIs is properly set. Go to Factory Settings >Unit Options > Board Config > HMI Config > Number Verify Modbus Address for the HMI. Refer to page 62 .
Stat Pressure Low	The space or duct pressure is below the limit configured in User Settings, which disables the unit.	Verify the space or duct pressure transducer wiring Verify the space or duct pressure reading to a manometer Verify the low pressure limit in User Settings .
Stat Pressure High	The space or duct pressure is above the limit configured in User Settings, which disables the unit.	Verify the space or duct pressure transducer wiring Verify the space or duct pressure reading to a manometer Verify the low pressure limit in User Settings .

Problem	Potential Cause	Corrective Action
FSC1 High Temp FSC2 High Temp	The high limit switch is tripped (open circuit).	Verify max discharge set point.
		Verify airflow.
		Verify accuracy of discharge temperature sensor.
		Verify furnace modulation. Refer to high/low fire settings, refer to page 94 .
FSC1 Rollout FSC2 Rollout	One or more flame rollout switch is tripped (open circuit). Rollout switches require manual reset.	Check wiring to the switches.
		Verify furnace modulation. Refer to high/low fire settings, refer to page 94 .
		Check for a blocked tube, low airflow, or low gas pressure.
FSC1 Vent Proving FSC2 Vent Proving	The vent proving switch is not proving airflow (open circuit).	Reset the switch.
		Inspect vent tubing. Check for damage or obstructions.
		Check bleed hole in proving switch.
		Check inducer motor wiring.
		Verify the inducer starts. Go to Service > Test Menu > Test Heating .
Low Refridge PS (Circuit 1/2/3)	The low pressure (suction pressure) switch tripped. Suction pressure dropped below 25psi. The switch auto resets when pressure rises above 39psi. Fault must be reset using reset lockouts after the switch is reset.	Verify there is at least 0.35" of pressure measured from the tube to atmosphere when the inducer is running
		Refer to " Vent Proving Switch (PS-01) " on page 142 .
		Check low pressure switch wiring.
		Verify coils are not restricting airflow.
		Verify air filters are not restricting airflow.
		Verify supply airflow.
High Refridge PS (Circuit 1/2/3)	The high pressure (discharge pressure) switch tripped, above 610psi. The switch requires manual reset when pressure drops below 480 PSI. Fault must be reset using reset lockouts after switch resets.	Review cooling and dehumidification set-points. Verify they are not causing the coil to freeze.
		Perform cooling test and verify refrigerant charge. Refer to " Monitoring the A/C System " on page 110 .
		Check high pressure switch wiring.
		Verify coils are not restricting airflow.
		Perform condenser fan test to make sure all fans are operational and modulate.
		Perform cooling test and verify refrigerant charge. Refer to " Monitoring the A/C System " on page 110 .

Problem	Potential Cause	Corrective Action	
Refrdg Dschrg Temp (Circuit 1/2/3) - Heat Pump Only	The refrigerant discharge line temperature switch has detected high temperature (heat pump sensor only).	Verify refrigerant high pressure switch operation. Reset if the switch is tripped.	
		Verify coils are not restricting airflow.	
		Verify air filters are not restricting airflow.	
		Perform condenser fan test to make sure all fans are operational and modulate.	
		Perform cooling test and verify refrigerant charge. Refer to “Monitoring the A/C System” on page 110.	
Oil Low (Circuit 1/2/3)	The Oil Level Sensor (OLS) reported no oil. For information on oil management, refer to “Compressor Information” on page 57.	Check OLS installation/wiring.	
		Check OLS operation, refer to “Oil Level Sensor (Sen-x)” on page 142.	
		Perform cooling test and verify refrigerant charge. Refer to “Monitoring the A/C System” on page 110.	
		For units equipped with an oil solenoid, check installation/wiring.	
		Verify oil level at sight glass after compressor has run for 5 min and also after comp has been off for 5 min.	
		Monitor OLS reading for extended period while comp is at max speed to confirm oil level.	
Env Cond Temp High (Circuit 1/2/3)	The discharge line pressure sensor is reporting higher than expected discharge pressure for current operating conditions.	Verify discharge sensor operation.	
Env Cond Temp Low (Circuit 1/2/3)		The discharge line pressure sensor is reporting lower than expected discharge pressure for current operating conditions.	Verify coils are not restricting airflow.
Env Evap Temp High (Circuit 1/2/3)			Verify air filters are not restricting airflow.
Env Evap Temp Low (Circuit 1/2/3)	The suction line pressure sensor is reporting higher than expected suction pressure for current operating conditions.	Verify supply airflow.	
Env Evap Temp High (Circuit 1/2/3)		The suction line pressure sensor is reporting lower than expected suction pressure for current operating conditions.	Perform condenser fan test to make sure all fans are operational and modulate.
Env Evap Temp Low (Circuit 1/2/3)	The suction line pressure sensor is reporting lower than expected suction pressure for current operating conditions.		Perform cooling tests and verify refrigerant charge. Refer to “Monitoring the A/C System” on page 110.

Problem	Potential Cause	Corrective Action
Env Angle	The indoor and outdoor coil operating temperatures (suction and discharge saturation temperatures) are out of range.	Verify suction and discharge pressure transducer readings are accurate.
		Verify coils are not restricting airflow.
		Verify air filters are not restricting airflow.
		Verify supply airflow.
		Perform condenser fan test to make sure all fans are operational and modulate.
		Perform cooling tests and verify refrigerant charge. Refer to “Monitoring the A/C System” on page 110.
Max Head Pressure (Circuit 1/2/3)	The max head pressure for the compressor is too high.	Verify discharge pressure transducer readings to gauge.
		Verify coils are not restricting airflow.
		Verify air filters are not restricting airflow.
		Verify supply airflow.
		Perform condenser fan test to make sure all fans are operational and modulate.
		Perform cooling tests and verify refrigerant charge. Refer to “Monitoring the A/C System” on page 110.
EEV Temp	The suction line thermistor is reading high temperatures while in a cooling call.	Verify suction line thermistor wiring.
		Verify suction line thermistor reading. Refer to “Temperature Sensor” on page 140.
Suction PS (Circuit 1/2/3)	The suction transducer is reading low pressure	Verify suction and discharge pressure transducer readings are accurate.
		Verify coils are not restricting airflow.
		Verify air filters are not restricting airflow.
		Verify supply airflow.
		Perform condenser fan test to make sure all fans are operational and modulate.
		Perform cooling tests and verify refrigerant charge. Refer to “Monitoring the A/C System” on page 110.
SLT Fault	Suction Line Temperature has surpassed 110°F for greater than 10 minutes and the EEV is at 100%.	Verify suction line thermistor wiring.
		Check sensor mounting location. Refer to page 52.
SLT Diff (Circuit 1/2/3)	Second suction line thermistor reading is 15 degrees apart from each other. One or more sensor’s are drifting.	Verify suction line thermistor wiring.
		Check sensor mounting location. Refer to page 52.

Problem	Potential Cause	Corrective Action
Electric Heater Fault	Voltage input is lost while the electric heater is active.	Verify electric heat wiring. check for 24V AC is present on terminal I. Check electric heater wiring to board connector J7 pin 10. Check incoming power at the heater disconnect. Check that the fuses are not blown and there is voltage to the line and load side of the main transformer in electric heater. Check the manual and auto reset limit switches to make sure they are not tripped.
Space RH Intake RH Discharge RH Return RH Exhaust RH Outside RH	The relative humidity sensor(s) is not reading correctly.	Verify sensor wiring to the schematic. For sensors with DIP switches, verify DIP switch settings are correct. Compare sensor readings to a psychrometer. Refer to “ Humidity/Temperature Sensors ” on page 139.
Comp VFD Not Auto	The compressor VFD is not in Auto mode.	Place the compressor VFD to Auto mode.
HMI MB Comm 1 HMI MB Comm 2 HMI MB Comm 3 HMI MB Comm 4 HMI MB Comm 5	Modbus Communication Error.	Verify control board dip switches match schematics. Verify HMI CAT5 cable. Verify the amount of HMIs is properly set. Go to Factory Settings >Unit Options >Board Config > HMI Config > Number Verify Modbus Address for the HMI. Refer to page 62 .
Power Card Temp Ctrl Card Temp	The VFD power or control card is overheating (above 175F).	Check compressor twisted shielded pair wiring. Compare VFD parameters to schematics. Check line/load wiring. Factory reset and program the drive. For CDS 803, refer to page 59 . Factory reset and program the drive. For CDS 302/303, refer to page 60 . Enable Compressor VFD Overheat protection if fault occurs when system is idle.

Problem	Potential Cause	Corrective Action
Earth Fault	The VFD senses there is current from the output phases to earth.	Check for shorts to ground between compressor and VFD.
		Disconnect wiring at compressor and meg compressor leg to ground.
		Disconnect wiring at compressor and measure resistance leg to leg.
		Reconnect wiring at compressor and disconnect wiring at load of compressor VFD. Meg test compressor through the wiring.
Ctrl Word Timeout	There is no communication to the VFD.	Check compressor twisted shielded pair wiring.
		Compare VFD parameters to schematics.
CO2 Shutdown CO2 Override CO2 Threshold	The CO2 PPM is above the limit setpoint.	Verify CO2 sensor wiring.
		Verify CO2 sensor PPM reading.
		Verify CO2 sensor setpoints.
ERV Supply Clogged Filter	Dirty or clogged filters/Advanced Cool Board (ACB) tubing.	Inspect filters. Clean or replace filters.
		Inspect airflow tubing at the ACB. Clean or replace tubing.
ERV Exhaust Clogged Filter		Recalibrate filters. Go to Service > Calibrate ERV.
ERV Deadband Fail	No temperature differential across the wheel.	Inspect ERV motor belt. Replace belt if broken/worn.
		Clean ERV wheel if needed.
		Make sure wheel turns freely. Correct any obstructions.
		Inspect ERV motor for failure.
ERV Exhaust Air Proving	No pressure differential detected across the exhaust air stream wheel section.	Inspect airflow tubing at the ACB. Clean or replace tubing.
		Verify ERV Wheel Side Panels are in place if applicable (Size 3 & 4 ERV)
		Verify the exhaust blower is operating.
ERV Exhaust RH	Exhaust RH Sensor reading 0% RH	Verify RH sensor dip switches are correctly set.
		Inspect exhaust RH sensor for signs of failure.
ERV Supply Missing Filter	Low or zero differential across the supply filter rack.	Verify filters are installed properly.
ERV Exhaust Missing Filter	Low or zero differential across the exhaust filter rack.	
ACB ERV Comm	ACB and MUA board miscommunication.	Check Cat 5 communication between the ACB and MUA board. Confirm ACB board is powered and MUA board is correctly programmed.
Contactor1 Proving Contactor2 Proving	Exhaust fan proving is enabled and the current transducer dry contact is open for fan #1 or fan #2.	Verify wiring to current switch.
		Check exhaust fan wiring.

Problem	Potential Cause	Corrective Action
Space Temp Disabled	The disable space temperature feature is active. The unit sensed a space temperature out of range and automatically reverted to discharge temperature control.	Check the space temp disable option in User Settings .
Damper Fault	Damper not responding.	Check dampers for proper operation and movement.
Damper Closed	Damper stuck closed.	
Excess OA	Damper stuck open.	Check wiring and connections.
No Economizer	The unit is not economizing.	Check for motor failures.
Economizer Fault	Improper economizing.	Check HMI settings. Check for damage temperature sensors.

Condensing Fan Blink Codes

The condensing fan is equipped with an LED indicator light for troubleshooting. Count the LED's blinks, refer to **Figure 58**, then compare to LED Code.

Figure 58 - Status LED

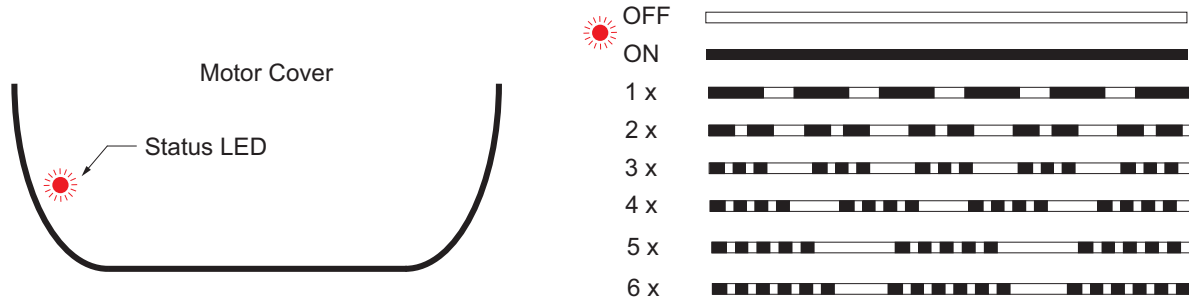

LED Code	Potential Cause	Corrective Action
OFF	No voltage supply	Unit switches OFF and automatically ON when the voltage has been restored. Check voltage supply.
ON	Normal operation without fault.	No action required.
1 x	No enable = OFF Terminals "D1" - "24 V" (Digital In 1) not bridged.	Switch OFF by external contact (see digital input).
2 x	Temperature management active The device has integrated active temperature management to protect the device from damage caused by excessively high interior temperatures.	In case of a temperature increase above the predetermined limits the modulation is linearly reduced. With a drop in temperature the modulation rises again linear. Check installation of the device and cooling of the motor.
3 x	Error rotor position Determination of the rotor position has failed.	After 8 starting tests, an error message is displayed. Check whether the motor can rotate freely (without line voltage).
4 x	Line failure (only for 3 ~ types) The device is provided with a built-in phase-monitoring function for the mains supply. In the event of a mains interruption (failure of a fuse or mains phase) the unit switches off after a delay (approx. 200 ms). Only functioning with an adequate load for the controller.	Following a shutoff, a startup attempt is made after approximately 15 seconds, if the voltage supply is high enough. This keeps occurring until all 3 supply phases are available again. Check power supply.
5 x	Motor blocked If no speed > 0 is measured for a specific time window with commutation, the error "Motor blocked" is triggered.	Device switches off, renewed attempt to start after about 2.5 sec. Final shutoff, when fourth starting test fails. It is then necessary to have a reset by disconnecting the line voltage. Check if motor is freely rotatable.
6 x	Failure power module Short circuit to earth or short circuit of the motor winding.	EC-Controller switches off, renewed attempt to start after about 70 sec. see code 9. Final shutoff, if - following a second starting test - a second fault detection is detected within a period of 75 seconds. It is then necessary to have a reset by disconnecting the line voltage.

LED Code	Potential Cause	Corrective Action
7 x	<p>DC-link undervoltage</p> <p>If the DC-link voltage drops below a specified limit the device will switch off.</p>	<p>If the DC-link voltage rises above the limit within 75 seconds, then the controller will attempt to start. Should the DC-link voltage stay for more than 75 seconds below the limit, the device will switch off with a fault message.</p>
8 x	<p>DC-link overvoltage</p> <p>If the DC-link voltage increases above a specified limit, the motor will switch off. Reason for excessively high input voltage or alternator motor operation.</p>	<p>If the DC-link voltage drops below the limit within 75 seconds, then the controller will attempt to start. Should the DC-link voltage stay above the limit for more than 75 seconds, the device will switch off with a fault message.</p>
9 x	<p>Cooling down period power module</p> <p>Cooling down period power module for approx. 70 sec. Final shutoff after 2 cooling-off intervals see code 6.</p>	<p>Power module cooling down period for approx. 70 sec. Final shutoff after 2 cooling-off intervals see code 6.</p>
10 x	<p>Communication fault</p> <p>If the communication watchdog is active, it signals that MODBUS communication is interrupted.</p>	<p>Response dependent on set watchdog mode (see MODBUS communication description). Check MODBUS communication.</p>
11 x	<p>Error motor start</p> <p>If a starting command is given (enable available and Setpoint > 0) and the motor does not start to turn in the correct direction within 5 minutes, then an error message will appear.</p>	<p>If it is possible to start the motor in the target direction of rotation after the error message, the error message will disappear. Should a voltage interruption occur in the meantime, the time taken up to the switch off will begin again. Check whether the motor can rotate freely (without line voltage). Check if the fan is driven in reverse direction by an air stream (see behavior in rotation by air current in reverse direction).</p>
12 x	<p>Line voltage too low</p> <p>If the line voltage drops below a specified limit the device will switch off.</p>	<p>If the line voltage rises above a specified limit within 75 seconds, then the controller will attempt to start. Should the line voltage stay below the specified limit for more than 75 seconds, the device will switch off with an error message.</p>
13 x	<p>Line voltage too high</p> <p>Cause to high input voltage If the line voltage increases above a specified limit, the motor will switch off.</p>	<p>If the line voltage drops below the specified limit within 75 seconds, then the controller will attempt to start. Should the line voltage stay above the specified limit for more than 75 seconds, the device will switch off with an error message.</p>
14 x	<p>Error peak current</p> <p>If the motor current increases above the specified limit (even in a short time-frame) the device will switch-off.</p>	<p>After a switch off the controller waits for 5 seconds then the controller attempt a start. Arises within 60 sec. in series 5 further disconnections a final switch off with fault indication follows. Should no further switch off be exceeded in 60 sec. the counter will be reset.</p>
17 x	<p>Temperature alarm</p> <p>Excess of the max. permissible inside temperature.</p>	<p>Controller switches off motor. Automatic restarting after cooling down. Check installation of the device and cooling of the controller.</p>
18 x	<p>System error</p> <p>Device has detected a system error. Only limited operation, or no operation at all, is possible.</p>	<p>The error is displayed immediately. The motor is switched off depending on the system error. Reset by disconnecting the voltage supply. If the error message persists, repair by the manufacturer is necessary.</p>

LED Code	Potential Cause	Corrective Action
20 x	<p>a) Vibration values If the vibration velocity rises above the specified limits, an error message is issued.</p>	<p>The error is displayed after the set time. The device continues to operate unchanged. Check the impeller for damage, contamination, or ice formation.</p>
	<p>b) Lifetime If the remaining service determined life falls below the defined limit, an error message is issued.</p>	<p>The error is displayed immediately. The device continues to operate unchanged. After consultation with the manufacturer, perform maintenance.</p>
21 x	<p>Error PFC-Control (only for version with 3 ~ PFC) Fault in PFC unit</p>	<p>With the factory settings, the motor continues to operate unchanged. If a motor shutdown is desired in response to a PFC failure, the parameter settings can be changed.</p>
∞ x	<p>Internal communication error Internal communication failure</p>	<p>Fault indication If error message persists, repair by the manufacturer is necessary.</p>
1 x — 2 x	<p>MODBUS Recovery function A failure in the MODBUS communication has been detected, e.g. incorrect communication parameters (baud rate, parity), wiring error.</p>	<p>The motor can be accessed in recovery mode using the following parameters: Address 254, 19200Baud / 8E1 Check the bus wiring and communication parameters.</p>

Compressor Drive VFD Troubleshooting Chart

Problem	Potential Cause	Corrective Action
Earth Fault	There is current from the output phases to ground (earth) in the cables, or the motor.	Check the cables from the converter to the compressor.
		Check for continuity from the compressor terminals to ground. There should be no continuity.
Control Word Timeout	There is no communication to the frequency converter. Only active if setting 8-04 is NOT set to [0] OFF.	Verify wiring, and connections are correct.
		Check cable connections to the converter.
		Increase the Control Word Timeout time setting 8-03.
		Check the communication components.
Over Current	This fault can be caused by shock loading, or quick acceleration with high inertia load.	Make sure the unit is OFF. Verify the motor shaft can be turned.
		Check the motor size matches the frequency converter.
		Check parameters 1-20 to 1-25 for correct setup.
Torque Limit	The torque has exceeded the value in setting 4-16 or 4-17.	Check for excessive current draw on the motor.
		If the motor torque limit is exceeded during ramp-up, extend ramp up time.
		If the generator torque limit is exceeded during ramp down, extend ramp downtime.
		If torque limit occurs while running, increase the torque limit. Verify the system operation can operate safely at a higher torque.
Inverter Overload	The converter is about to cut out because of an overload. The thermal protection issues a warning at 98% and an alarm at 100%. This converter cannot be reset until the counter is at 90%.	Compare current output from LCP to the converter's rated current.
		Compare the output shown from the LCP with measured motor current.
		Verify the drive load on the LCP. Monitor the value. The counter will increase when running above the continuous current rating. The counter will decrease when running below the continuous current rating.
DC Under Volt	If the intermediate circuit voltage drops below the under-voltage limit, the frequency converter checks if a 24V DC backup supply is connected. If no 24V DC backup supply is connected, the converter trips after a fixed time delay. The time delay varies with unit size.	Check that the supply voltage matches the frequency converter voltage.
		Perform input voltage test.
DC Over Volt	If the intermediate circuit voltage exceeds the limit, the converter trips after a time.	Connect a brake resistor.
		Extend the ramp time.
		Change the ramp type.
		Activate the functions in 2-10 Brake Function.
		Increase 14-26 Trip Delay at Inverter Fault.
If the alarm/warning occurs during a power sag, the solution is to use kinetic back-up (14-10 Mains Failure).		
Short Circuit	There is short-circuiting in the motor or motor wiring.	Remove power to the frequency converter and repair the short circuit.

Problem	Potential Cause	Corrective Action
Mains Phase Loss	A phase is missing on the supply side, or the mains voltage imbalance is too high. This message also appears for a fault in the input rectifier on the frequency converter. Options are programmed at parameter 14-12.	Check the supply voltage and supply currents to the frequency converter. Refer to “ Compressor Drive Input/Output (VFD-02) ” on page 139.
	U Phase Loss	Refer to “ Compressor Drive Input/Output (VFD-02) ” on page 139.
V Phase Loss		
W Phase Loss		
24V Supply Low	The 24V DC is measured on the control card. The external 24V DC backup power supply maybe overloaded.	Check wiring.
		Check backup supply.
Mains Fail	This warning/alarm is only active if the supply voltage to the frequency converter is lost and parameter 14-10 is NOT set to [0] No Function.	Check the fuses to the frequency converter and mains power supply to the unit.
Safe Stop	Loss of the 24V DC signal on terminal 37 has caused the filter to trip.	Apply 24V DC to terminal 37 and reset the filter.
Start Fail	The speed has not been able to exceed parameter 1-77 during start within the allowed time.	Motor may be locked.
Speed Limit	When the speed is not within the specified range in parameters 4-11 and 4-13, the converter shows a warning. When the speed is below the specified limit in parameter 1-86 (except when starting or stopping), the frequency converter will trip.	This alarm is reset automatically, and the compressor restarts automatically.
Current Limit	The current is higher than the value in 4-18 Current Limit. Ensure that the motor data in parameters 1-20 to 1-25 are set correctly. Possibly increase the current limit. Be sure that the system can operate safely at a higher limit.	Make sure that motor data in parameters 1-20 to 1-25 are set correctly.
		Possibly increase the current limit. Be sure that the system can operate safely at a higher limit.

Compressor Troubleshooting Chart

Problem	Potential Cause	Corrective Action
Compressor will not start	Shorted or broken wires	Use a multi-meter to check the compressor wiring harness for an open or short circuit.
	Locked rotor	Check continuity of the compressor. Replace if failed.
	Low voltage	Test voltage.
	Internal failure	If no other failure is present, there is an internal failure. Replace the compressor.
Compressor runs intermittently	Shorted or broken wires	Check the compressor wiring harness for an open or short circuit.
	Loose connections	Secure connections.
	Shorted or grounded compressor	Check for continuity from the compressor terminals to ground. There should be no continuity.
	Overcharge of refrigerant	Recover part of the refrigerant.
	Dirty outdoor coil	Clean the outdoor coil.
	Incorrect thermostat location	Relocate thermostat.
	Electronic Expansion Valve (EEV)	Verify the correct expansion valve is installed.
	Hot Gas Reheat Valve	Refer to “Hot Gas Reheat Valve (HG-1/HG-2)” on page 146.
	Faulty reversing valve	Test reversing valve.
Defrost control	Test defrost control.	
Compressor cycles on overload	Shortage of refrigerant	Test for leak. Recharge.
	Restricted discharge line	Repair or replace as needed.
	Non-condensables in system	Recover the charge, evacuate the system. Recharge the system.
	Recirculation of condensing air	Remove airflow obstruction.
	Electronic Expansion Valve (EEV)	Make sure the expansion valve is operating properly.
Compressor making abnormal noise	Overcharge of refrigerant	Recover part of the refrigerant.
	Loose hardware	Tighten the mounting bolts.
	Internal failure	If no other failure is present, replace the compressor.
	Liquid in compressor head	Check “Superheat and Subcooling” on page 134 and EEV position.
Low suction pressure	Low charge	Check “Superheat and Subcooling” on page 134.
	Restricted discharge line, drier, or reversing valve	Repair as needed.
Compressor oil issues	Low oil	If sight glass is available, check oil level. Add oil.
		If there is an oil level sensor. Refer to “Oil Level Sensor (Sen-x)” on page 142.
	Imbalance of refrigerant	Check “Superheat and Subcooling” on page 134.
	Compressor running too slow for a long period of time	Adjust compressor speed.

Airflow Troubleshooting Chart

Problem	Potential Cause	Corrective Action
Fan Inoperative	Blown fuse/Open circuit breaker	Replace fuse or reset circuit breaker and check amps.
	Disconnect switch in "Off" position	Turn to "On" position.
	Door switch	Verify door is closed properly.
		Check door switch wiring and switch.
	Motor wired incorrectly	Check motor wiring to wiring diagram located on fan motor.
	Motor starter overloaded	Reset starter and check amps.
HMI set to "Blower Off"	Set HMI to "Blower On."	
Motor Overload	Fan rotating in the wrong direction	Verify fan is rotating in the direction shown on rotation label.
	Fan speed is too high	Reduce fan RPM.
	Motor wired incorrectly	Check motor wiring to wiring diagram located on fan motor.
		Check the fan wiring.
		Check fan rotation using the HMI.
	Overload in starter set too low	Set overload to motor FLA value.
	Motor HP too low	Determine if HP is sufficient for job.
Duct static pressure lower than design	Reduce fan RPM.	
Insufficient Airflow	Fan rotating in the wrong direction	Verify fan is rotating in the direction shown on rotation label.
		Check the fan wiring.
		Check fan rotation using the HMI.
	Poor outlet conditions	There should be a straight clear duct at the outlet.
	Intake damper not fully open	Inspect damper linkage and replace damper motor if needed.
	Duct static pressure higher than design	Improve ductwork to eliminate or reduce duct losses.
	Fan speed too low	Increase fan RPM. Do not overload motor.
	Indoor coil dirty or frozen	Clean Indoor Coil and filters.
	Supply grills or registers closed	Open and adjust.
Dirty or clogged filters	Clean and/or replace.	
Excessive Airflow	Fan speed too high	Reduce fan RPM.
	Filters not installed	Install filters.
	Duct static pressure lower than design	Reduce fan RPM.
Excessive Vibration and Noise	Fan speed is too high	Reduce fan RPM.
	Damaged or unbalanced wheel	Replace wheel.
	Fan is operating in the unstable region of the fan curve	Refer to performance curve for fan.
	Bearings need lubrication or replacement	Lubricate or replace.

Furnace Troubleshooting Chart

Problem	Potential Cause	Corrective Action
Furnace Does Not Light/Stay Lit	Main gas is off	Open main gas valve.
	Shut off valve closed	Open shut off valve.
	ON/OFF gas valve is off	Turn ON/OFF gas valve on.
	Gas pressure out of range	Adjust to proper gas pressure.
	Air in gas line	Purge gas line.
	Dirt in burner orifices	Clean orifices with compressed air.
	Spark igniter rod out of position	Relocate spark igniter rod to proper area.
	No spark at igniter	Refer to “Flame Safety Control (FSC-01)” on page 144.
	Defective flame safety controller	
	Excessive drafts	Re-direct draft away from unit.
	Safety device has cut power	Check limits.
		Check airflow switch and tubing at the MUA board.
	Dirty flame sensor	Clean flame sensor.
	Defective flame sensor	Change heating set-points to call for heat.
	Defective valve	Refer to “Gas Valves” on page 143.
	Loose gas valve wiring	
Thermostat not calling for heat	Change heating set-points to call for heat.	
Unit cycling on high limit	Check gas pressure. Increase airflow through furnace, if required.	
Not Enough Heat	Main gas pressure too low	Increase main gas pressure – do not exceed 14 in. wc inlet pressure.
	Unit locked into low fire	Check wiring or modulating valve settings. Refer to “Furnace Start-Up Summary” on page 93.
	Too much airflow	Decrease airflow if possible.
	Furnace undersized	Check design conditions.
	Gas controls not wired properly	Refer to “Gas Valves” on page 143.
	Thermostat setting too low	Increase thermostat setting.
	Thermostat malfunction	Check thermostat.
Too Much Heat	Defective modulating gas valve	Check/replace modulating valve.
	Thermostat setting too high	Decrease thermostat setting.
	Unit locked into high fire	Check modulation valve settings. Refer to “Furnace Start-Up Summary” on page 93.
	Thermostat wired incorrectly	Check thermostat wiring.
	Too much primary air	Reduce primary air.
	Manifold pressure set too high	Reduce manifold pressure.
Lifting Flames or Flashback	Dirty orifice	Check and clean orifice.
	Orifice too large	Check orifice size.
	Insufficient primary air	Increase primary air.
Yellow Tipping Flames	Misaligned orifice	Check manifold alignment.
	Insufficient primary air	Increase primary air.
	Orifice too large	Check orifice size.
Floating Flames or Flame Rollout	Manifold pressure too high	Decrease manifold pressure.
	Blocked vent	Check venting system.
	Misaligned orifice	Check manifold alignment.

Superheat and Subcooling

When determining superheat, use **Table 17** to convert the low side pressure gauge (suction line) to the appropriate temperature. Subtract the converted temperature from the suction line surface temperature. There should be approximately a **20°F** difference. Superheat monitors what state the refrigerant is when it leaves the evaporator coil. High superheat indicates the refrigerant has picked up more heat than designed. Low superheat indicates the refrigerant has not picked up enough heat and can cause flooding in the compressor. If superheat is incorrect, verify subcool first before making changes to the system.

Table 17 - R410A Pressure Temperature

Temperature (°F)	Refrigerant Pressure	Temperature (°F)	Refrigerant Pressure
-45	7.7	55	156.6
-40	10.8	60	170.7
-35	14.1	65	185.8
-30	17.8	70	201.8
-25	21.9	75	218.7
-20	26.3	80	236.5
-15	31.2	85	255.4
-10	36.5	90	275.4
-5	42.2	95	296.4
0	48.2	100	318.6
5	55	105	341.9
10	62.3	110	366.4
15	70.2	115	392.3
20	78.7	120	419.4
25	87.8	125	447.9
30	97.5	130	447.9
35	107.9	135	509.4
40	118.9	140	542.5
45	130.7	145	577.3
50	143.3	150	613.9

Subcooling monitors what state the refrigerant is in when it leaves the condensing coil. High subcooling means the condenser is flooded with liquid refrigerant, stacked on the EEV. Low subcooling means the condenser is starving and operating less efficiently. The subcool measurement represents how much the refrigerant in the condenser is cooled past the saturation point. When determining subcool, convert the high side pressure gauge (condensing coil liquid line) to the appropriate temperature in **Table 17 on page 134**. Subtract the liquid line surface temperature from the converted temperature. The proper amount of subcool is dependent on the outdoor air temperature. Refer to **Figure 59** for proper subcool.

- Measure subcool with condensing fans set to target **110°F** discharge condensing temp in test cooling. If the discharge condensing temp is greater than 110°F, but condensing fans are at 100% speed, subcool measurements are still accurate. Subcool readings with sub 110°F discharge condensing temperatures are not valid. Subcool readings should not be taken when ambient temps are below 60°F.
- Subcool tests should be ran with the reheat valve closed. The blower and OA damper set to the same speed and position that the unit will be operating at.
- If the superheat is high and the subcool is low under normal operating conditions, the system may be low on charge. Determine the cause of low refrigerant and repair as necessary. Refer to **“Charging System Low on Refrigerant” on page 114**.
- If the superheat is low and the subcool is high under normal operating conditions, the system may be over-charged. Refer to **“Recovering Refrigerant from the System” on page 111**.
- If the superheat is high and the subcool is high under normal operating conditions, there could be a blockage in the coil, or line set.
- High Ambient (HA), Low Ambient (LA), Extreme Low Ambient (ELA), and Heat Pump (HP) options modify the amount of factory provided charge, and will affect subcool measurements.
- Standard, low ambient, and extreme low ambient cooling units should target the “Target Subcool Standard, ELA, LA Cooling Units” solid black line. Min and max allowable subcool is shown by the dashed black lines.
- High ambient cooling units, as well as standard and high ambient heat pump units ship with less charge, so the solid blue “Target Subcool All HA Units or Standard HP Units” line should be targeted. Subcool must be in the blue shaded area.
- Extreme low ambient heat pump units ship with additional charge, so the solid red “Target Subcool ELA HP Units” line should be targeted. Subcool must be in the red shaded area.
- Subcool tolerance is always +/- 5°F from the target subcool line for that unit.
- To increase subcooling, add refrigerant charge. To decrease subcooling, remove refrigerant charge.

NOTE: Do not add or remove refrigerant based on the impulse to achieve a subjective subcooling value. Ambient temperatures may affect subcooling.

Figure 59 - Outdoor Air Temperature vs. Subcool

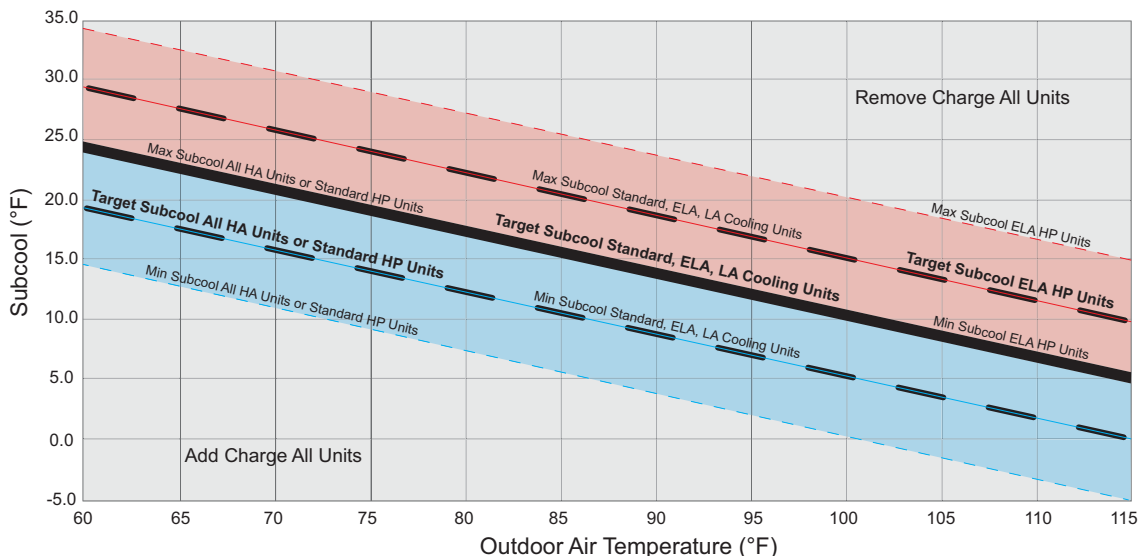

Component Check/Testing

On-board Airflow Sensor

1. Verify the tubing to the on-board sensor is connected. Confirm there are no kinks, cracks, or damage to the tubing. Replace tubing if needed.
2. With the unit ON, set the blower to “Manual” through the HMI. Go to **Factory Settings > Unit Options > Blower Config > Blower Control > Manual**.
3. Use the HMI to modulate the blower speed to achieve system’s minimum design CFM. Go to **User Settings > Fan Speed** to adjust blower frequency or percentage.
4. Monitor the static pressure on the HMI through the service menu for at least one minute. Go to **Service > Variable Values > Inputs > Onbd PS**.
5. Record the lowest pressure reading.
6. Set the “PS Set Point” to 0.05” w.c. below the lowest static pressure reading that is observed. Go to **Factory Settings > Unit Options > Blower Config > Airflow Proving > PS Set Point**.

Example: If the lowest pressure reading observed is 0.20” w.c., set the “PS Set Point” to 0.15” w.c.

Figure 60 - Board Airflow Sensor

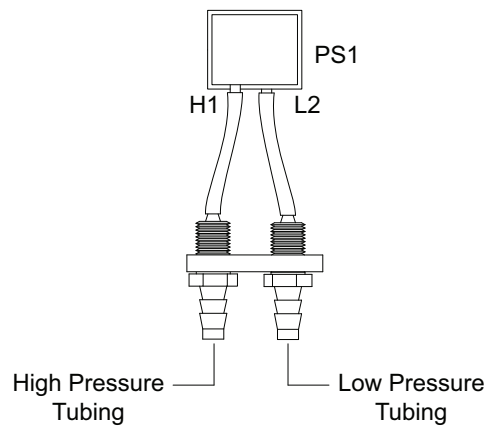

Clogged Filter Switch (PS-10)

1. The vent tube should be connected to the low side port (**Figure 61**). A fault will occur when the switch senses a negative pressure.
2. If the “Clogged Filters” fault is active:
 - Check the filters. If the filters are clogged or damaged, replace as needed. Check for any other obstructions in the unit.
 - Verify the electrical connections are secure and tight. Verify vent tube is not pinched or damaged.
 - When the unit is powered ON:
 - There should be **24-28V AC** at connector J13 pin 5 to ground. If the voltage reading is incorrect, check the wiring harness and voltage at the circuit board.
 - There should be **0V AC** at connector J13 pin 12 to ground. If there is voltage at pin 12, check the adjustment of the switch.

Clogged Filter Switch Field Adjustment

Follow these steps if performing a part replacement, or to calibrate the switch.

- Install the switch. Install the vent tube on the low side port.
- Install the electrical connections. Power the unit ON. Set dampers to 100% open for outdoor air. Monitor the HMI screen.
- Use a screwdriver to turn the adjustment screw clockwise until it is completely seated in the switch. Use material suitable to block 50-75% of the intake from the outside of the unit.

Turn the adjustment screw counter-clockwise in one turn increments (waiting 3 seconds per adjustment) until the “Clogged Filters” fault is active. Turn the adjustment screw a 1/4 to 1/2 turn clockwise until the fault is no longer active.

Figure 61 - Clogged Filter Switch

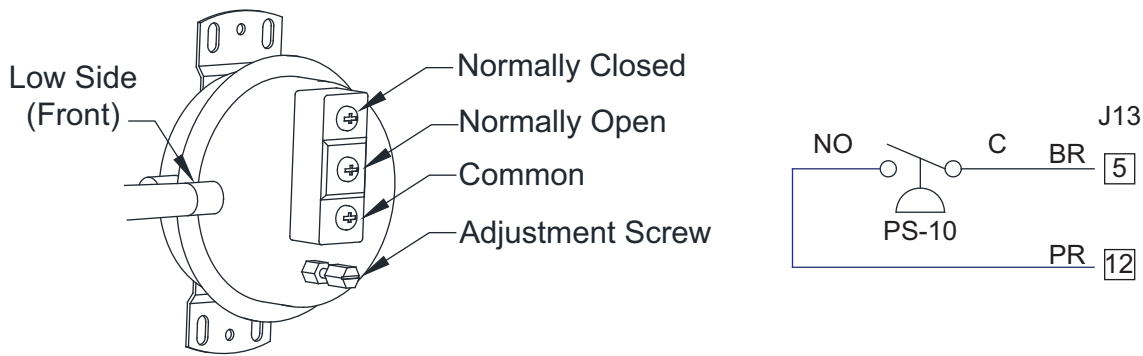

Low Refrigeration Pressure Switch (SW-15)

1. For the low pressure switch (**Figure 62**), insert a back probe tool at connector J36 pin 1 and pin 2. Power the unit ON. Check for voltage at the following pins:
 - J36 pin 1 to ground. There should be **24-28V AC**.
 - J36 pin 2 to ground. There should be **24-28V AC**.
 - If the voltage is incorrect, continue to step 2.
 - If the voltage is correct, the system may need to be charged. Refer to **“Monitoring the A/C System” on page 110**.
2. Check the electrical circuit. Power the unit OFF. Check for continuity in the wiring harness.
 - J36 pin 1 to pin 2. There should be continuity.
 - J36 pin 1 to ground. There should be no continuity.
 - J36 pin 2 to ground. There should be no continuity.
 - If any of the continuity readings are incorrect, verify the wiring is not damaged. If no damage is found, replace the low pressure switch.
 - If all of the continuity readings are correct, there may be an issue with transformer.

Figure 62 - Low Refrigeration Pressure Switch

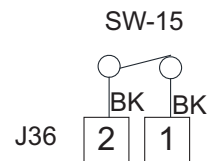
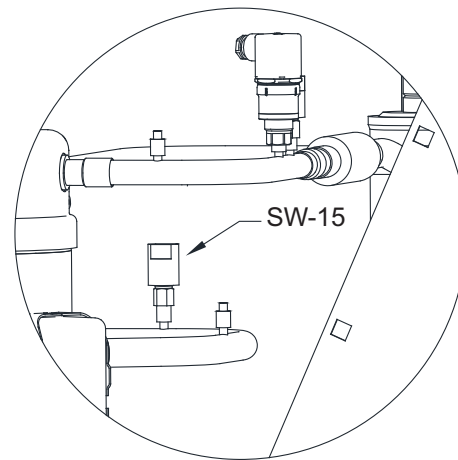

High Refrigeration Pressure Switch (SW-16)

1. If a high pressure switch (**Figure 63**) failure occurred, manually reset the switch.
2. For the high pressure switch, insert a back probe tool at connector J36 pin 3 and pin 4. Power the unit ON. Check for voltage at the following pins:
 - J36 pin 3 to ground. There should be **24-28V AC**.
 - J36 pin 4 to ground. There should be **24-28V AC**.
 - If the voltage is incorrect, continue to step 3.
 - If the voltage is correct, the system maybe overcharged. Refer to **“Monitoring the A/C System” on page 110**.
3. Check the electrical circuit. Power the unit OFF. Check for continuity in the wiring harness.
 - J36 pin 3 to pin 4. There should be continuity.
 - J36 pin 3 to ground. There should be no continuity.
 - J36 pin 4 to ground. There should be no continuity.
 - If any of the continuity readings are incorrect, verify the wiring is not damaged. If no damage is found, replace the high pressure switch.
 - If all of the continuity readings are correct, there may be an issue with transformer.

Figure 63 - High Refrigeration Pressure Switch

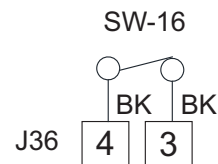
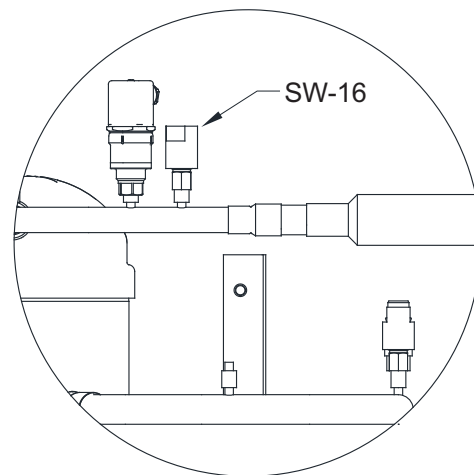

Compressor Drive Input/Output (VFD-02)

1. Power the unit OFF. Verify there is no damage to the wiring. Make sure all connections are secure and connected. Verify wiring connections to the schematic. Refer to **Figure 64** for details.
2. Verify the unit is OFF. Check for open or short circuits in the wiring harness.
3. Power the unit ON. Check for voltage at the following terminals:
 - Terminal L1 to ground. Verify reading to nameplate voltage.
 - Terminal L2 to ground. Verify reading to nameplate voltage.
 - Terminal L3 to ground. Verify reading to nameplate voltage.
 - Terminal T1/U to ground. Voltage will vary with compressor speed.
 - Terminal T2/V to ground. Voltage will vary with compressor speed.
 - Terminal T3/W to ground. Voltage will vary with compressor speed.

Figure 64 - Compressor Drive

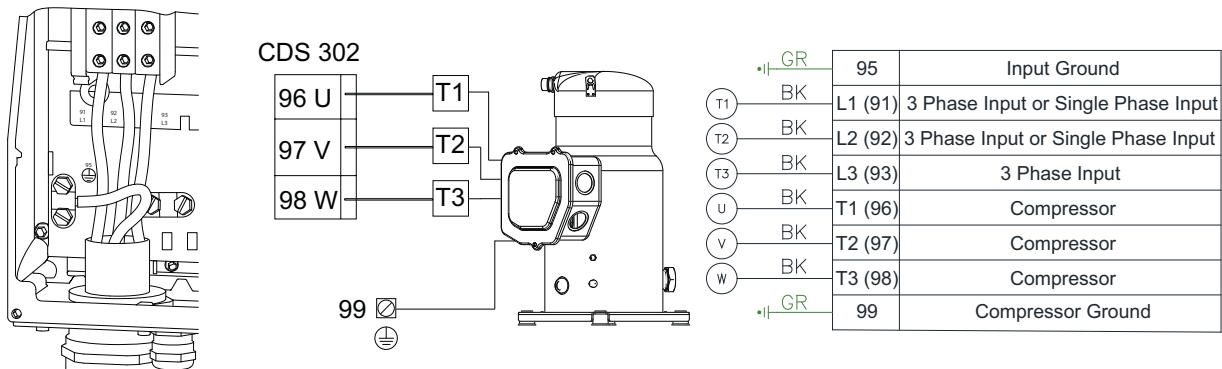

Humidity Temperature Sensor

Intake (HUM-1)/Space (HUM-2)/Discharge (HUM-3)

Refer to Figure 65 for component locations. Check the following:

1. Verify the wiring is connected properly to the terminal block.
2. Verify the DIP switches are set properly. Make sure switch 7 and 8 are ON.
3. Check the wiring is connected properly at the switch.
4. Make sure all the connections are clean, and that there is no condensation on the RH sensor circuit board.

Figure 65 - Humidity/Temperature Sensors

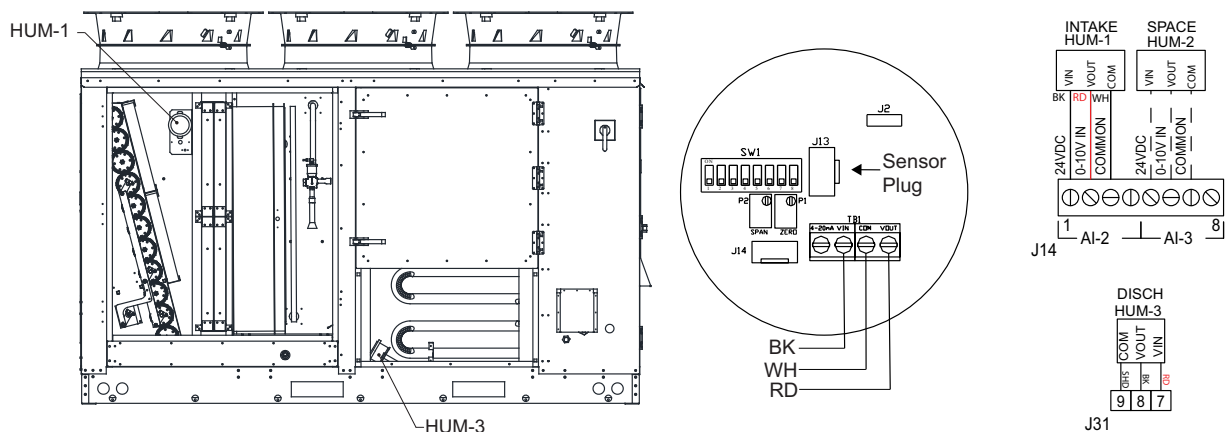

Temperature Sensor

Intake (SN-01)/Return (SN-02)/Outdoor (SN-03)/Discharge (SN-04)/Space (HUM-2)

Refer to **Figure 66** component locations. Check the following:

1. Make sure the unit is OFF.
2. Make sure the wires are connected properly.
3. Measure the resistance of the temperature sensor. Use the temperature/ohm chart to determine your readings.

Connector J15 Sensor Connections:

- SN-01 – J15 pin 1 to pin 2
- SN-02 – J15 pin 3 to pin 4
- SN-03 – J15 pin 5 to pin 6
- SN-04 – J15 pin 7 to pin 8
- SN-05 – J15 pin 9 to pin 10
- HUM-2 – J15 pin 9 to pin 10

Connector J35 Sensor Connections:

- SN-06 – J35 pin 1 to pin 2
- SN-07 – J35 pin 3 to pin 4
- SN-08 – J35 pin 5 to pin 6
- SN-09 – J35 pin 7 to pin 8
- SN-10 – J35 pin 9 to pin 10

- If there is **0 ohms**, the sensor or wires are shorted.

- If there is **infinite (OL) ohms**, the sensor or wires are open.

If the sensor or wiring has failed, replace the sensor.

NOTE: SN-03 is located behind the damper assembly.

Figure 66 - Temperature Sensors

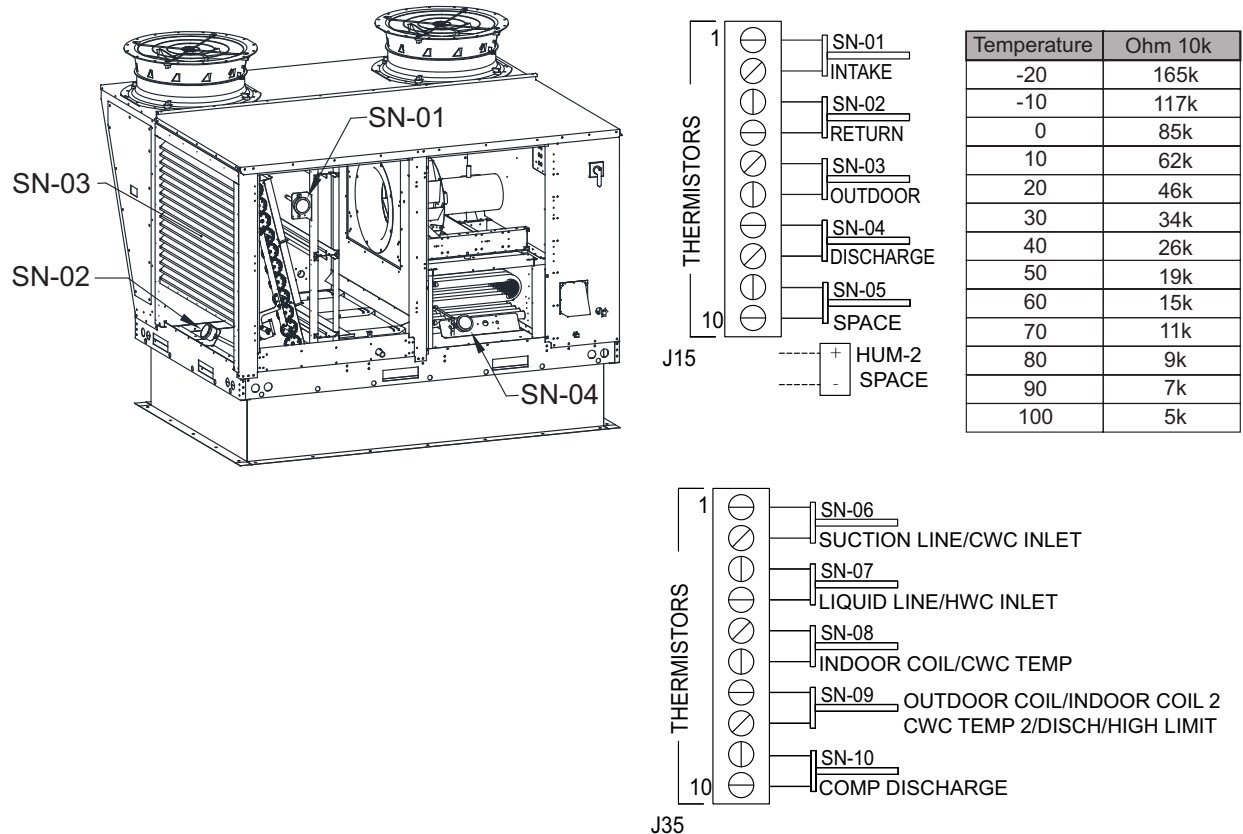

High Gas Pressure Switch (PS-03)

1. Turn the unit ON. Reset the lever on the switch. Gas pressure must be lower in the chamber for the reset latch to be set properly. Verify the high gas pressure switch is set to **12 in. w.c.**
2. Remove the cover. Make sure the wiring is set up for Normally Closed (N.C.) contact (**Figure 67**).
3. Verify the ON/OFF gas valve, and modulating valve is set properly. Refer to “**Start-Up Procedure Heating**” on page 93.
4. Check for voltage:
 - Back probe connector J13 pin 4 to ground. There should be **24-28V AC**.
 - Back probe connector J13 pin 11 to ground. There should be **24-28V AC**.
 - If the voltage reading is incorrect, check the wiring for an open or short circuit. If the wiring is correct, the switch has failed. Replace the switch.
 - If the voltage reading is correct, and the switch reset corrected the fault, there may have been an intermittent fault.

Figure 67 - High Gas Pressure Switch

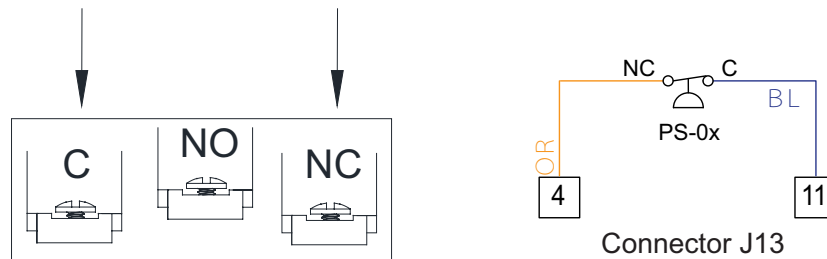

Low Gas Pressure Switch (PS-04)

1. Turn the unit ON. Verify the inlet pressure gauge is reading the correct pressure.
 - Natural gas - **7 in. w.c. – 14 in. w.c.**
 - Propane - **11 in. w.c. – 14 in. w.c.**
- NOTE: If the reading is incorrect, contact the gas supply company.**
2. Reset the lever on the switch. Gas pressure must be higher in the chamber for the reset latch to be set properly. If the reset did not work, continue with the next step.
 3. Remove the cover. Make sure the wiring is set up for Normally Closed (N.C.) contact (**Figure 68**).
 4. Check for voltage:
 - Back probe connector J13 pin 3 to ground. There should be **24-28V AC**.
 - Back probe connector J13 pin 10 to ground. There should be **24-28V AC**.
 - If the voltage reading is incorrect, check the wiring for an open or short circuit. If the wiring is correct, the switch has failed. Replace the switch.
 - If the voltage reading is correct, and the switch reset corrected the fault, there may have been an intermittent fault.

Figure 68 - Low Gas Pressure Switch

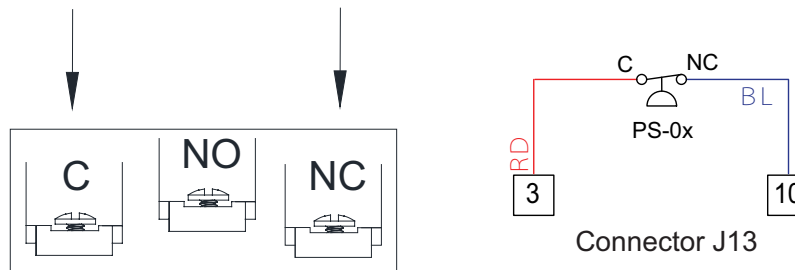

Vent Proving Switch (PS-01)

1. Verify wiring is connected properly.
2. Check that the vent tubing is routed correctly. Make sure the tube is not pinched or clogged.
3. Verify the bleed hole is not clogged (**Figure 69**). The bleed hole reduces condensation build-up in the switch and tubing.
4. Make sure the unit is OFF. Check the switch. Remove electrical connections. Check for continuity between pin "C" to pin "NO". There should be no continuity.
 - If there is continuity, the switch has failed. Replace the switch.
 - If there is no continuity, re-connect the electrical connections. Continue to the next step.
5. Connect a manometer between the pressure switch and hose. Turn the unit ON. Monitor the manometer. Verify the value (**w.c.**) on the switch is correct.
 - If the reading is below the value, there is an issue with the vacuum. Refer to "**HMI Fault Codes**" on **page 116** for more information.
 - If the reading is above the value, continue to the next step.
6. With the unit ON. Check for voltage:
 - Back probe connector J7 pin 14 to ground. There should be **24-28V AC**.
 - Back probe connector J7 pin 10 to ground. There should be **24-28V AC**.
 - If the voltage reading is incorrect, check the wiring for an open or short circuit. If the wiring check is correct, the switch has failed. Replace the switch.
 - If the voltage reading is correct, there may have been an intermittent fault.

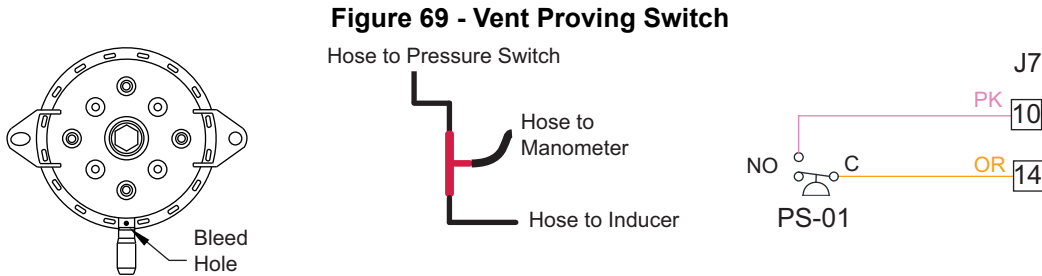

Oil Level Sensor (Sen-x)

Refer to "**Compressor Information**" on **page 57** for more information on oil level sensor (**Figure 70**).

1. Verify the compressor is not running. Remove the oil level sensor from the compressor.
2. Turn the unit ON. Verify the compressor is OFF by pressing OFF on the LCP panel.
3. Go to Service > Open/Closed Status > Inputs > Oil Sensor: The status should be NC.
 - If the OLS diagnostic tool (120Z0560) is available, insert tool over the optical sensor. The status should change to NO.
 - If the OLS diagnostic tool (120Z0560) is not available, place a light source tightly over the optical sensor. The status should change to NO.
4. Verify checks:
 - If the reading does not change, replace the sensor.
 - If the reading changes (sensor is good), and an oil boost does not clear fault, check for low oil or leaks in the system.

Figure 70 - Oil Level Sensor

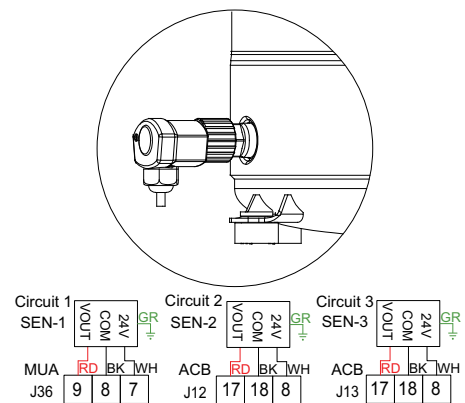

Main (On/Off) Gas Valve (VA-01)

The main gas valve (**Figure 71**) is located in the burner cabinet. Units that use 500MBH and larger furnaces are equipped with two shut-off valves internal to a single body.

1. Make sure the wiring is connected properly.
2. Make sure the gas valve is ON.
3. Turn the unit ON. Check for voltage. Check for voltage across the pins on the gas valve. There should be **24-28V AC**.
 - If the voltage reading is incorrect, check the wiring for an open or short circuit.
 - If the voltage reading is correct, the gas valve may be faulty.

Figure 71 - Main Gas Valve

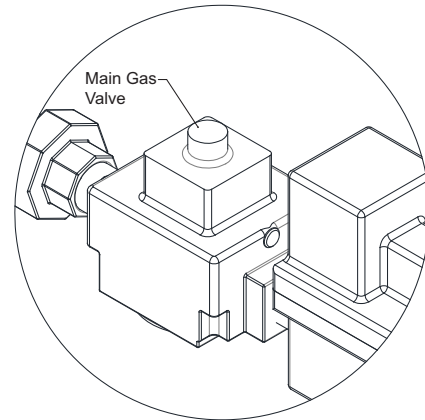

Modulating Gas Valve (VA-05)

The modulating gas valve (**Figure 72**) is located in the main burner cabinet.

1. Make sure the wiring is connected properly. Check the wiring using a multi-meter for open or short circuits.
 - Terminal 1 – Signal (+) to J7 pin 6
 - Terminal 2 – Signal (-) to J7 pin 7
 - Terminal 3 – Power **24V DC (+)** to H4
 - Terminal 4 – Power (-) to N4
 - If any damaged wiring is found, repair or replace.
 - If any open or short circuits are found, repair or replace.
 - If any wiring is connected incorrectly, correct the wiring.

Figure 72 - Modulating Gas Valve

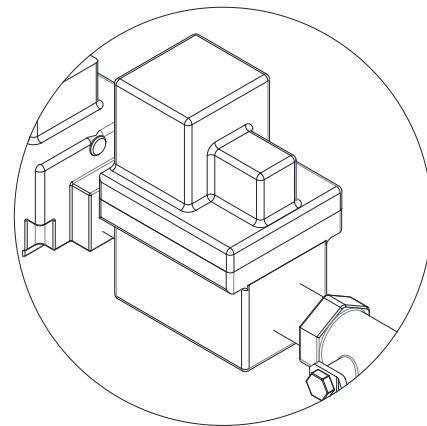

NOTE: The wiring connection is polarity sensitive.

2. Make sure the DIP switches are all in the OFF position (factory setting). This will set the valve to receive a **0-10V DC** signal. If the unit is set up for an analog control system, refer to **Table 14**.
3. Make sure the valve has been adjusted properly. Refer to **“Start-Up Procedure Heating” on page 93**.
4. If the unit has been running, restart the unit. Check for voltage:
 - Connector J7 pin 6 to ground. There should be **10V DC**. The voltage reading will drop after the unit has been running.
 - Check for voltage between H4 to N4 on the terminal block. There should be **24-28V AC**. This voltage reading will be constant.
 - If the voltage reading is incorrect, check voltage to the IBT control board.
 - If the voltage reading is correct, there may be an issue with the modulating valve.

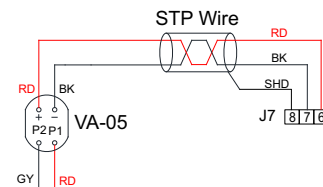

Flame Safety Control (FSC-01)

The FSC is located in the main control cabinet.

1. Verify wiring and connections are properly connected (**Figure 73**).
2. Turn the unit ON. Use the HMI to set the unit in test mode.
 - Service > Test Menu > Test Heating > Run Low Fire Test > Stages All
 - Refer to “**Flame Safety Control (FSC)**” on **page 96** for operation of sequence.

Determine the symptom below:

Symptom	Action
Control does not start	<ul style="list-style-type: none"> • Check wiring. • Check for a 24V AC transformer failure. • Check circuit breaker. • Check LED light.
Thermostat ON – no spark	<ul style="list-style-type: none"> • Check wiring to thermostat input (TH). • Faulty thermostat. • Check LED light.
Blower ON – no Trial For Ignition (TFI) after purge delay	<ul style="list-style-type: none"> • Check wiring. • Check for flame fault. • Air flow fault, check tubes and connections to MUA Board airflow switch. • Check connection at PSW terminal. • Faulty control (Check voltage between L1 and IND. There should be 24V AC).
Valve ON – no spark during TFI	<ul style="list-style-type: none"> • Check wiring. • Shorted ignitor electrode. • Check cable to ignitor.
Spark ON – valve OFF	<ul style="list-style-type: none"> • Check wiring. • Valve coil open. • Check voltage at V1.
Flame during TFI – no flame sensed after TFI	<ul style="list-style-type: none"> • Check flame rod position. • Check cable to flame rod. • Poor ground connection at burner. • Poor flame.

3. Turn the unit ON. If the LED is blinking, verify the fault:
 - Steady ON = Internal controller failure
 - 1 flash = Airflow fault. 2 flashes = Flame without call for heat. 3 flashes = Ignition lock out

Figure 73 - FSC Wiring

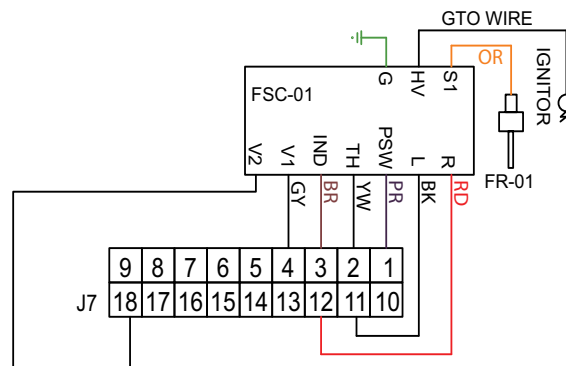

Intake Damper Motor Assembly (MT-06)

1. Verify the wiring is correct.
2. Check the wiring for open or short circuits.
3. Verify the positive signal from J18 pin 2 is connected to the assembly at pin 3.
4. Verify the negative signal from J18 pin 9 is connected to the assembly at pin 1.
5. Test the damper rotation. Turn the unit ON. Use the HMI to monitor the movement of the damper.
 - User Settings > Outdoor Air Voltage > 10V (default).
 - Adjust the voltage setting and monitor the damper movement.
 - If the damper movement and voltage reading are correct, test is complete.
 - If the damper movement and voltage reading are incorrect, continue to the next step.
6. Check transformer voltages.
 - If there is an issue with the transformer or wiring, repair or replace.
 - If the transformer check is good, check for mechanical failures.

Field installation/adjustment

1. Rotate the damper shaft to its fail-safe position (closed). Mount the actuator with the counterclockwise "CCW" out. Refer to **Figure 74**.
2. If the universal clamp is not on the correct side of the actuator, move it to the correct side.
3. Slide the actuator onto the shaft. Position the clamp so that the pointer of the tab is at the top of the rotation.
4. Lock the clamp to the actuator using the retaining clip.
5. Tighten the nuts on the V-bolt. Torque to **6-8 ft-lb**.
6. Secure to strap.
7. Make sure the rotation is set correctly. Y = 0 set to CCW.
8. Test the spring return damper rotation.
 - You can use the crank handle to test manually.
 - Turn the unit ON. Use the HMI to monitor the movement of the damper.
 - Service > Test Menu > Test Misc > Outdoor Air
 - Adjust the voltage setting and monitor the damper movement. **0V – Outdoor air dampers closed; 10V – Outdoor air dampers open.**
 - If the damper operates properly, the installation is correct.
 - If the damper operates incorrectly, adjust as required. If adjustment cannot be made, check the wiring is correct. Verify to the unit's wiring schematics.

Figure 74 - Intake Damper Motor Assembly

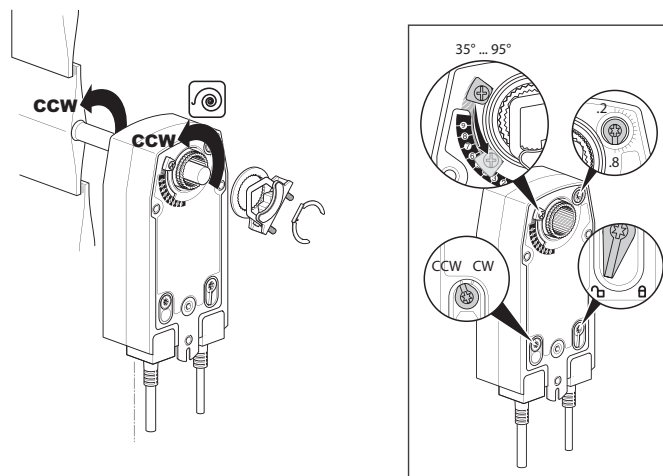

Hot Gas Reheat Valve (HG-1/HG-2)

Units with a single reheat valve, HG-1 will be a three-way valve. Units that use dual reheat valves will have HG-1 in-line to the reheat coil inlet and HG-2 in-line to the outdoor (condensing) coil inlet. Refer to **Figure 75** for valve differences.

Power the unit OFF. Verify there is no damage to the wiring. Check the wiring connections to the MUA board connector, verify wiring connections to the schematic. Make sure all connections are secure and connected.

Electronic Expansion Valve (EEV-1)

The Electronic Expansion Valve (EEV-1) wiring (**Figure 76**) is connected to the MUA Board.

1. Power the unit OFF. Verify there is no damage to the wiring. Make sure all connections are secure and connected.
2. Use a multi-meter to measure the resistance in the electronic expansion valve harness from:
 - The black wire to white wire. There should be **90-100 ohms**.
 - The red wire to green wire. There should be **90-100 ohms**.
 - The white wire to ground. There should be infinite resistance (open circuit).
 - The black wire to ground. There should be infinite resistance (open circuit).
 - The red wire to ground. There should be infinite resistance (open circuit).
 - The green wire to ground. There should be infinite resistance (open circuit).
 - If the readings are incorrect, there may be an issue with the electronic expansion valve. Replace EEV if necessary.
 - If the readings are correct and there are no issues with the electronic expansion valve, there may be an issue with the superheat controller.

Figure 75 - Hot Gas Reheat

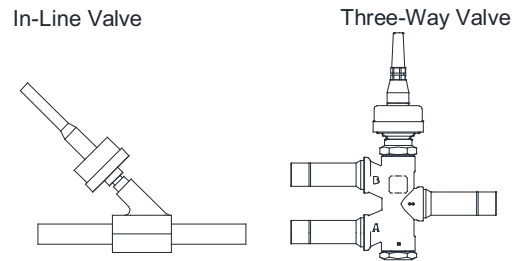
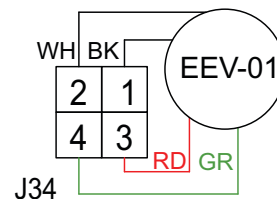

Figure 76 - EEV Wiring Reference



Power Vent (MT-02)

1. If the power vent motor is not operating properly, power the unit OFF.
2. Verify there is no damage to the vent proving switch or vent tube.
3. Verify there is no damage to the wiring, motor or capacitor. Make sure all connections are secure and connected. Verify wiring connections to the schematic. If damage is found, replace the damaged component(s).
4. Check the motor's electrical circuit.

For standard furnaces (Figure 77):

Disconnect the wiring connections from pin J17 and pin J21. Power the unit ON. Check for voltage from pin J17 to pin J21 on the board. There should be **115-120V AC**.

- If the voltage reading is incorrect, verify there is **120V AC** to the circuit board.
- If the voltage reading is correct, check the motor's capacitor. If the capacitor is OK, there may be an issue with the power vent motor.

For 400HE (High Efficiency) Furnaces (Figure 77):

1. Power the unit OFF. Check the ground circuit on the five pin connector. Check the ground circuit on the three pin connector. If there is an issue with the ground circuit, repair the circuit. If there is not an issue with the ground circuit, power the unit ON.
2. With the unit powered ON, check for **24V DC** between the (+) and (-) terminals. If the voltage reading is incorrect, check the **24V DC** power supply.
3. Check the PWM signal from the **EC+** to ground. The voltage reading should vary. If the voltage reading is incorrect, verify connections to the circuit board.
4. Check for **120V AC** between the **H** and **N** terminals. If the voltage reading is incorrect, check the circuit breaker and the main transformer (TR-01).
5. Check the **24V AC** HE Furnace Relay (RE-B). When the relay is actuated, check the following:
 - Black wire terminal to ground. There should be **120V AC**.
 - Red wire terminal to ground. The voltage will vary.
 - If the voltage reading is incorrect, the relay may have failed.
 - If the voltage reading and all other checks are within specifications, there may be an issue with the power vent motor.

Figure 77 - Power Vent Motor

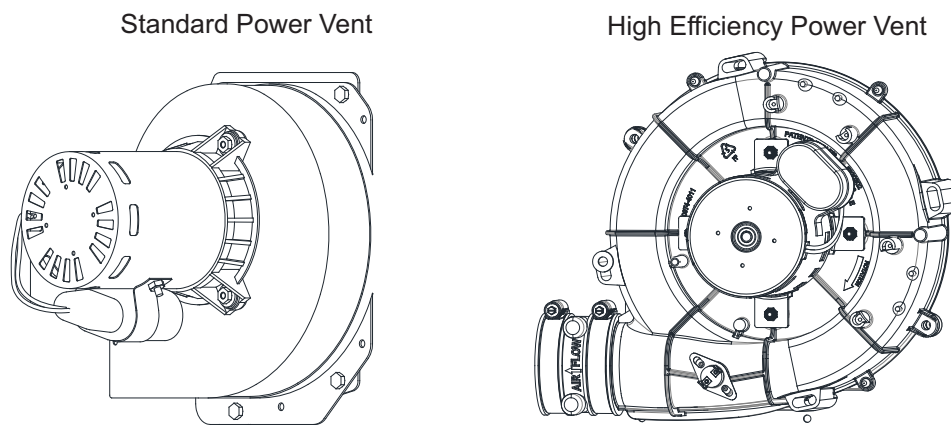

MAINTENANCE

WARNING: DO NOT ATTEMPT MAINTENANCE ON THIS EQUIPMENT UNTIL THE ELECTRICAL SUPPLY HAS BEEN COMPLETELY DISCONNECTED AND THE MAIN GAS SUPPLY VALVE HAS BEEN TURNED OFF.

To guarantee trouble-free operation of this unit, the manufacturer suggests following these guidelines. Most problems associated with failures are directly related to poor service and maintenance.

Record any maintenance or service performed on this unit in the documentation section located at the end of this manual.

General Maintenance

- Fan inlet and approaches to ventilator and coils should be kept clean and free from any obstruction. Clean both the indoor and outdoor coils regularly to maintain unit efficiency.
- Motors are normally permanently lubricated. Check bearings periodically. If they have grease fittings, lubricate each season. Use caution when lubricating bearings, wipe the fittings clean, the unit should be rotated by hand while lubricating. **Caution: Use care when touching the exterior of an operating motor. Motors normally run hot and may be hot enough to be painful or cause injury.**
- All fasteners should be checked for tightness each time maintenance checks are performed prior to restarting unit.
- Fans require very little attention when moving clean air. Occasionally oil and dust may accumulate causing imbalance. If the fan is installed in a corrosive or dirty atmosphere, periodically inspect and clean the wheel, inlet, and other moving parts to ensure smooth and safe operation.
- The Energy Wheel will require very little attention when moving clean air. Occasionally oil and dust may accumulate, degrading performance. If the ERV is installed in a dirty atmosphere, periodically inspect and clean the wheel, belt, and other moving parts to ensure smooth and safe operation.
- Before each heating season, verify that the drain on the bottom of each common flue box of every furnace in the unit is clear.

Every 3 Months

Filters must be cleaned and/or replaced quarterly, and more often in severe conditions. Washable filters, located in the intake louver or ERV module, can be washed in warm soapy water. When re-installing filters, be sure to install with the same size and rated filter and with **airflow in the correct direction** as indicated on the filter. Refer to “**Filters**” on **page 151** for sizing and quantity.

E-coated coils should be inspected and cleaned quarterly. Standard coils should be inspected and cleaned every six months during the “**Cooling Season Maintenance**” on **page 149**. Refer to “**Coil Cleaning Procedure**” on **page 150** for coil maintenance information.

Heating Season Maintenance

- Verify that the drain on the bottom of the flue box in the unit is clear.
- Inspect bolts and set screws for tightness. Tighten as necessary.
- Inspect the wiring on the unit and replace components where necessary.
- Inspect motor for cleanliness. Clean exterior surfaces only. Remove dust and grease from the motor housing to ensure proper motor cooling. Remove dirt and grease from the wheel and housing to prevent imbalance and damage.
- The heat exchanger should be checked for cracks. The heat exchanger should be replaced immediately if cracks are detected. With a soft cloth, remove any built-up dirt or oil on the exterior surface of the heat exchanger.
- Inspect the combustion blower motor for cleanliness. Clean exterior surfaces of the combustion blower motor only. Removing excess dust and grease guarantees proper motor cooling.
- Before each heating season, examine the burner and gas orifices. Inspect burner ports for foreign debris. Check the heat exchanger, and spark igniter for cleanliness. Use a wire brush to remove any soot, dirt, or grease from the burner or orifices.
- If equipped with an ERV, inspect the energy wheel, belt, and drive motor. Inspect for foreign debris or residue build-up, segments of the energy wheel can be removed and washed clean with warm water.

Cooling Season Maintenance

- Before each cooling season, verify that the drain on the bottom indoor coil drain pan is clear. Inspect bolts and set screws for tightness. Tighten as necessary.
- Inspect the wiring on the unit and replace components where necessary.
- Inspect motor for cleanliness. Clean exterior surfaces only. Remove dust and grease from the motor housing to ensure proper motor cooling. Remove dirt and grease from the wheel and housing to prevent imbalance and damage.
- Inspect the indoor and outdoor coil for dirt and bent fins. Clean or replace as necessary. Refer to “**Coil Cleaning Procedure**” on page 150.
- Check the outdoor fans for proper rotation and operation. Clean all debris from fan guards.
- Inspect all return air dampers, fresh air dampers, and linkage to ensure free operation. Lubricate as necessary.
- With the unit running, check and record the ambient temperature, superheat, compressor suction, and discharge pressures. Record this data on the back of this manual.
- If equipped with an ERV, inspect the energy wheel, belt, and drive motor. Inspect for foreign debris or residue build-up, segments of the energy wheel can be removed and washed clean with warm water.

NOTE: Do NOT release refrigerant to the atmosphere! If adding or removing refrigerant is required, the service technician must comply with all federal, state, and local laws.

Coil Cleaning Procedure

Do not use a pressure washer or high-water pressure when cleaning the coil.

Proper maintenance and cleaning will help preserve the performance of coils and avoid corrosion over the length of the equipment's life. Equipment exposed to dusty, dirty, or corrosive environments, requires an inspection and cleaning more frequently. Always use water to rinse the coil down. Hot and cold water with mild dish soap are acceptable.

CAUTION: NO COIL CLEANERS ARE PERMITTED. IF COIL CLEANERS ARE UTILIZED, THE UNIT'S WARRANTY IS VOID.

NOTE: Always wear eye protection, gloves, and other protective clothing when cleaning.

1. Shut the system OFF. Spray the coil surface with only water to rinse off loose residue. Allow the water to soak for 10-20 minutes to loosen surface residue.
2. Thoroughly rinse the coil with only warm water (~100°F) until all signs of residue are eliminated (it should not be brackish or contain excessive dissolved minerals).
3. Verify the coil is clean, and that no deposits are present. Repeat steps 1 and 2 if the coil is not fully clean.
4. Allow the unit to dry completely before turning the electrical power on or returning the unit to service.
5. Always clean tools, sprayer, roof, nearby areas, and equipment thoroughly with water.
6. Place the system back into service.

Coil cleaners cannot be utilized. These are aggressive products that are corrosive and damage the equipment.

Extensively rinse coils from the bottom of the equipment and all other surrounding metal surfaces.

Maintenance Quick Reference Chart

Component	Maintenance	Interval
Filters	Clean or replaced.	Every 3 months
Damper assembly	Inspect and clean louvers and gutters.	Every 3 months
Drain Pans	Clean and clear of obstruction.	Every heating/cooling season
Bolts and Screws	Inspect bolts and screws. Verify all hardware is secure and tight.	Every heating/cooling season
Wiring and Electrical	Inspect all wiring, and electrical components.	Every heating/cooling season
Blower Motor	Inspect motor for cleanliness, and proper rotation.	Every heating/cooling season
Heat Exchanger	Inspect for cracks or damage.	Every heating/cooling season
Power Vent Motor	Inspect motor for cleanliness.	Every heating/cooling season
Burner and Gas Orifices	Inspect for cleanliness.	Every heating/cooling season
Indoor/Outdoor Coil	Check for damaged fins and cleanliness of the coil.	Every heating/cooling season
Outdoor Fans	Check for proper rotation, operation, and cleanliness.	Every heating/cooling season
Damper Assembly	Inspect the linkage and movement.	Every heating/cooling season
Unit Operation	Verify the unit pressures. Refer to "Basic Service" on page 109.	Every heating/cooling season

Filters

Table 18 - Louvered Intake Filter Quantity Chart (Washable)

Unit Housing Size	16" x 20" x 2"	16" x 25" x 2"	20" x 20" x 2"	20" x 25" x 2"
Size 1	2	x	x	x
Size 2	x	x	x	2
Size 3	x	4	x	x
Size 4	x	x	8	x

Unit Housing Size	16" x 20" x 2"	16" x 25" x 2"
Size 1 ERV	4	x
Size 2 ERV	4	x
Size 3 ERV	x	4
Size 4 ERV	8	x

Table 19 - Internal Filter Quantity Chart (Throw Away)

Unit Housing Size	16" x 16" x 2"	16" x 20" x 2"	20" x 20" x 2"	20" x 25" x 2"
Size 1	4	x	x	x
Size 2	x	4	x	x
Size 3	x	x	x	4
Size 4	x	x	12	x

Unit Housing Size	16" x 16" x 2"	16" x 20" x 2"	20" x 20" x 2"	16" x 25" x 2"	25" x 25" x 2"
Size 1 ERV	4	x	4	x	x
Size 2 ERV	x	4	2	x	x
Size 3 ERV	x	x	x	8	x
Size 4 ERV	x	16	x	x	x

NOTE: Quantity subject to change based on filter options. Optional 4" thick filters available upon request.

Resetting Unit

If the flame safety control is locked out (alarm light on), reset the unit by:

1. Press the FSC Reset push-button, refer to **Figure 78**. If pressing the reset fails, continue to step 2.
2. Turn OFF power to the unit.
3. Turn power to the unit back ON.

Figure 78 - Reset Buttons (MUA Board)

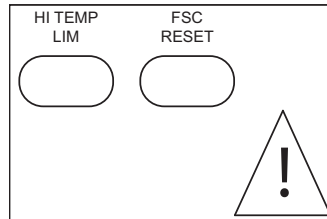

Emergency Shutdown of Unit

To shutdown the unit in the event of an emergency, do the following:

1. Turn power OFF to the unit from main building disconnect.
2. Turn the external disconnect switch to the OFF position.
3. CLOSE the inlet gas valve located on the heater.

Prolonged Shutdown of Unit

For prolonged shutdown, the following steps should be done:

1. Turn the external disconnect switch to the OFF position.
2. CLOSE the inlet gas valve located on the heater.

To re-start the unit, the following steps should be done:

1. Turn the external disconnect switch to the ON position.
2. OPEN the inlet gas valve located on the heater.

Start-Up and Maintenance Documentation

START-UP AND MEASUREMENTS SHOULD BE PERFORMED AFTER THE SYSTEM HAS BEEN AIR BALANCED AND WITH THE COOLING ON (warranty will be void without completion of this form).

Job Information

Job Name		Service Company	
Address		Address	
City		City	
State		State	
Zip		Zip	
Phone Number		Phone Number	
Fax Number		Fax Number	
Contact		Contact	
Purchase Date		Start-up Date	

Unit Information

Name Plate and Unit Information		Field Measure Information		
Model Number		Motor Voltage		
Serial Number		Motor Amperage*		
Unit Voltage		MUA Blower RPM		
Unit Hertz		Ambient Wet Bulb Temp °F/C		
Unit Phase		Ambient Dry Bulb Temp °F/C		
Unit FLA		Cond Suction Pressure psi	C1	C2
Unit Supply HP		Cond Suction Temp °F/C	C1	C2
Gas Type		Cond Liquid Pressure psi	C1	C2
Min. Btu/Hr		Cond Liquid Temp °F/C	C1	C2
Max. Btu/Hr		Cond Subcooling °F/C	C1	C2
Measured Temp Rise °F/C		Cond Superheat °F/C	C1	C2
		Air Flow Direction - Correct?		

Maintenance Record

Date of Visit

Field Measured Information – Initial Readings				Field Measured Information – Final Readings			
Motor Voltage				Motor Voltage			
Motor Amperage*				Motor Amperage*			
MUA Blower RPM				MUA Blower RPM			
Ambient Wet Bulb Temp °F/C				Ambient Wet Bulb Temp °F/C			
Ambient Dry Bulb Temp °F/C				Ambient Dry Bulb Temp °F/C			
Cond Suction Pressure psi	C1		C2	Cond Suction Pressure psi	C1		C2
Cond Suction Temp °F/C	C1		C2	Cond Suction Temp °F/C	C1		C2
Cond Liquid Pressure psi	C1		C2	Cond Liquid Pressure psi	C1		C2
Cond Liquid Temp °F/C	C1		C2	Cond Liquid Temp °F/C	C1		C2
Cond Subcooling °F/C	C1		C2	Cond Subcooling °F/C	C1		C2
Cond Superheat °F/C	C1		C2	Cond Superheat °F/C	C1		C2

***If measured amps exceed the FLA rating on the nameplate, fan RPM must be reduced to decrease the measured amps below the nameplate FLA rating.**

Maintenance Record

Date of Visit

Field Measured Information – Initial Readings		
Motor Voltage		
Motor Amperage*		
MUA Blower RPM		
Ambient Wet Bulb Temp °F/C		
Ambient Dry Bulb Temp °F/C		
Cond Suction Pressure psi	C1	C2
Cond Suction Temp °F/C	C1	C2
Cond Liquid Pressure psi	C1	C2
Cond Liquid Temp °F/C	C1	C2
Cond Subcooling °F/C	C1	C2
Cond Superheat °F/C	C1	C2

Field Measured Information – Final Readings		
Motor Voltage		
Motor Amperage*		
MUA Blower RPM		
Ambient Wet Bulb Temp °F/C		
Ambient Dry Bulb Temp °F/C		
Cond Suction Pressure psi	C1	C2
Cond Suction Temp °F/C	C1	C2
Cond Liquid Pressure psi	C1	C2
Cond Liquid Temp °F/C	C1	C2
Cond Subcooling °F/C	C1	C2
Cond Superheat °F/C	C1	C2

Maintenance Record

Date of Visit

Field Measured Information – Initial Readings		
Motor Voltage		
Motor Amperage*		
MUA Blower RPM		
Ambient Wet Bulb Temp °F/C		
Ambient Dry Bulb Temp °F/C		
Cond Suction Pressure psi	C1	C2
Cond Suction Temp °F/C	C1	C2
Cond Liquid Pressure psi	C1	C2
Cond Liquid Temp °F/C	C1	C2
Cond Subcooling °F/C	C1	C2
Cond Superheat °F/C	C1	C2

Field Measured Information – Final Readings		
Motor Voltage		
Motor Amperage*		
MUA Blower RPM		
Ambient Wet Bulb Temp °F/C		
Ambient Dry Bulb Temp °F/C		
Cond Suction Pressure psi	C1	C2
Cond Suction Temp °F/C	C1	C2
Cond Liquid Pressure psi	C1	C2
Cond Liquid Temp °F/C	C1	C2
Cond Subcooling °F/C	C1	C2
Cond Superheat °F/C	C1	C2

Maintenance Record

Date of Visit

Field Measured Information – Initial Readings		
Motor Voltage		
Motor Amperage*		
MUA Blower RPM		
Ambient Wet Bulb Temp °F/C		
Ambient Dry Bulb Temp °F/C		
Cond Suction Pressure psi	C1	C2
Cond Suction Temp °F/C	C1	C2
Cond Liquid Pressure psi	C1	C2
Cond Liquid Temp °F/C	C1	C2
Cond Subcooling °F/C	C1	C2
Cond Superheat °F/C	C1	C2

Field Measured Information – Final Readings		
Motor Voltage		
Motor Amperage*		
MUA Blower RPM		
Ambient Wet Bulb Temp °F/C		
Ambient Dry Bulb Temp °F/C		
Cond Suction Pressure psi	C1	C2
Cond Suction Temp °F/C	C1	C2
Cond Liquid Pressure psi	C1	C2
Cond Liquid Temp °F/C	C1	C2
Cond Subcooling °F/C	C1	C2
Cond Superheat °F/C	C1	C2

***If measured amps exceed the FLA rating on the nameplate, fan RPM must be reduced to decrease the measured amps below the nameplate FLA rating.**

As a result of our dedication to constant improvements and quality, the MANUFACTURER reserves the right to update specifications without notice. Please refer to MANUFACTURER’S website for up to date documentation.