

Modular Packaged Unit

Installation, Operation and Maintenance Manual

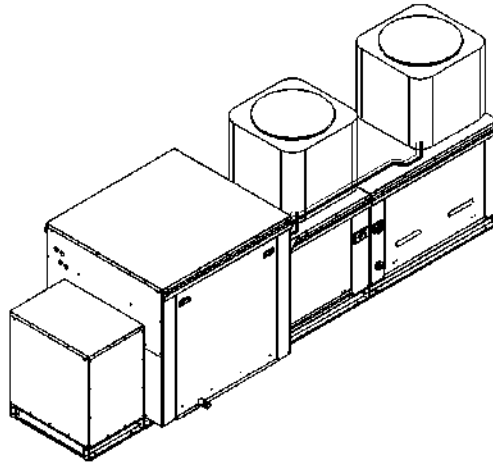

Modular Packaged Cooling Unit

FOR YOUR SAFETY

The use and storage of gasoline or other flammable vapors and liquids in open containers in the vicinity of this appliance is hazardous.

FOR YOUR SAFETY

If you smell gas:

1. Open windows.
2. Do not touch electrical switches.
3. Extinguish any open flames.
4. Immediately call your gas supplier.

Warning!! Spreader Bar with length matching that of this entire unit **MUST** be used while hoisting this unit. **All** lifting lugs must be utilized while hoisting. Manufacturer is not liable for any damage or injuries resulting from failure to do so.

RECEIVING AND INSPECTION

Upon receiving unit, check for any interior and exterior damage, and if found, report it immediately to the carrier. Also check that all accessory items are accounted for and are damage free. Turn the blower wheel by hand to verify free rotation and check the damper (if supplied) for free operation.

WARNING!!

Improper installation, adjustment, alteration, service or maintenance can cause property damage, injury or death. Read the installation, operating and maintenance instructions thoroughly before installing or servicing this equipment. **ALWAYS** disconnect power and gas prior to working on heater.

Save these instructions. This document is the property of the owner of this equipment and is required for future maintenance. Leave this document with the owner when installation or service is complete.

TABLE OF CONTENTS

WARRANTY	4
INSTALLATION	5
Mechanical	5
Site Preparation	5
Assembly	6
Curb and Ductwork	6
Optional Moisture Eliminator Panel	8
Overflow Switch	8
Plumbing Connections	8
ELECTRICAL	9
Table 2 - Copper Wire Ampacity	9
MUA/Condenser Fan to Building Wiring Connection	10
Variable Frequency Drive (VFD) Installation Instructions	11
VFD Programming	12
ACTECH SMV VFD CROSS-REFERENCE TABLE	13
OPERATION	14
Special Tools Required	14
Start-up Procedure	14
Checking the Refrigerant Charge	15
Superheat and Adjusting TXVs	16
Checking Heating Mode for Units with Heat Pumps	17
Sequence of Operation-Cooling with Direct, Indirect, or Electric Heat	17
Sequence of Operation-Reheat	18
Sequence of Operation-Liquid Bypass	18
Sequence of Operation-Cooling Only or Heat Pump	18
Board Menu	21
Troubleshooting Chart	23
MAINTENANCE	24
General Maintenance	24
2 weeks after startup	24
Every 3 months	25
Yearly	25
Coil Cleaning Procedure	25
Start-Up and Maintenance Documentation	26
Job Information	26
Unit Information	26

WARRANTY

This equipment is warranted to be free from defects in materials and workmanship, under normal use and service, for a period of 2-years from date of shipment. This warranty shall not apply if:

1. The equipment is not installed by a qualified installer per the MANUFACTURER'S installation instructions shipped with the product.
2. The equipment is not installed in accordance with federal, state and local codes and regulations.
3. The equipment is misused or neglected, or not maintained per the MANUFACTURER'S maintenance instructions.
4. The equipment is not operated within its published capacity.
5. The invoice is not paid within the terms of the sales agreement.

The MANUFACTURER shall not be liable for incidental and consequential losses and damages potentially attributable to malfunctioning equipment. Should any part of the equipment prove to be defective in material or workmanship within the 2-years warranty period, upon examination by the MANUFACTURER, such part will be repaired or replaced by MANUFACTURER at no charge. The BUYER shall pay all labor costs incurred in connection with such repair or replacement. Equipment shall not be returned without MANUFACTURER'S prior authorization and all returned equipment shall be shipped by the BUYER, freight prepaid to a destination determined by the MANUFACTURER.

INSTALLATION

It is imperative that this unit is installed and operated with the designed airflow, gas, and electrical supply in accordance with this manual. If there are any questions about any items, please call the service department at **1-866-784-6900** for warranty and technical support issues.

Mechanical

WARNING: DO NOT RAISE VENTILATOR BY THE INTAKE HOOD, BLOWER OR MOTOR SHAFT, OR BEARINGS – USE ALL LIFTING LUGS PROVIDED WITH A SPREADER BAR OR SLINGS UNDER THE UNIT – USE CARE NOT TO DAMAGE EXPOSED REFRIGERATION LINES.

CLEARANCES

The top, back and front surfaces of this unit may not be installed less than 6” from combustible materials. The base may be installed on combustible surfaces. Allow 24” minimum service clearance on both sides of this unit. Do not enclose top of condensers blocking airflow.

Site Preparation

1. Provide clearance around installation site to safely rig and lift equipment (**Figure 1**) into its final position. Supports must adequately support equipment. Refer to manufacturer’s estimated weights.
2. Consider general service and installation space when locating unit.
3. Locate unit close to the space it will serve to reduce long, twisted duct runs.
4. Do not allow air intake to face prevailing winds. Support unit above ground or at roof level high enough to prevent precipitation from being drawn into its inlet. The inlet must also be located at least 10 feet away from any exhaust vents. The unit inlet shall be located in accordance with the applicable building code provisions for ventilation air.

Figure 1 – Lifting Lug Location

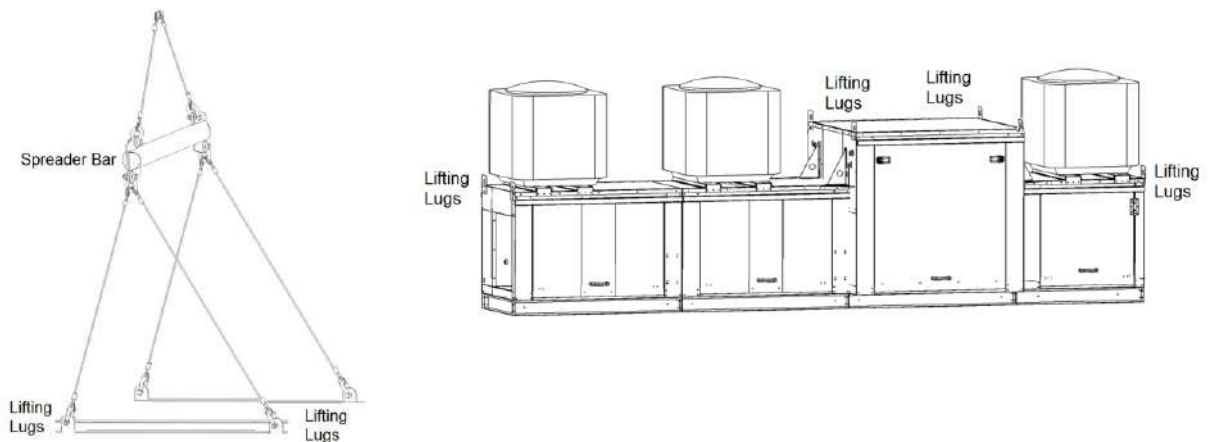

Assembly

Intakes and curbs are shipped unassembled. Upon unit arrival, follow the following procedure to assemble the intake to the heater:

1. Apply silicone or weatherproof gasket on the backside of the flanges of the intake hood or v-bank intake.
2. Screw the flanges of the intake hood or v-bank to the unit with the supplied sheet metal screws. If the unit is a modular unit with a v-bank or evaporative cooler section, the v-bank or evaporative cooler will bolt to the main unit with the bolts provided. Place caulk on the outside of the screws to prevent water leaks.

Curb and Ductwork

This fan was specified for a specific CFM and static pressure. The ductwork attached to this unit will significantly affect airflow performance. When using rectangular ductwork, elbows must be radius throat, radius back with turning vanes. Flexible ductwork and square throat/square back elbows should not be used. Any transitions and/or turns in the ductwork near the fan outlet will cause system effect. System effect will drastically increase the static pressure and reduce airflow. Refer to **Table 1** for duct sizing recommendations.

Follow SMACNA standards and manufacturer's recommendations for the duct runs. Fans designed for rooftop installation should be installed on a prefabricated or factory-built roof curb. Follow curb manufacturer's instructions for proper curb installation. The unit should be installed on a curb and/or rail that meets local code height requirements. Verify the duct connection and fan outlet are properly aligned and sealed. Secure fan to curb through vertical portion of the ventilator base assembly flange using a minimum of eight (8) lug screws, anchor bolts or other suitable fasteners (not furnished). Shims may be required depending upon curb installation and roofing material. Check all fasteners for tightness. **Figure 2** and **Figure 3** show different mechanical installation configurations.

Table 1 – Recommended Supply Ductwork

Blower Size (Inches)	Discharge	Duct Size (Inches)	Straight Duct Length (Inches)
10	Side	14 x 14	48
	Down		
15D, 16Z, 18Z	Side	20 x 20	72
	Down	14 x 14	48
12	Side	16 x 16	54
	Down		
15	Side	20 x 20	72
	Down		
20D, 20Z, 22Z	Side	26 x 26	108
	Down	20 x 20	72
18	Side	24 x 24	86
	Down		
24D, 25Z	Side	30 x 30	108
	Down	24 x 24	86
20	Side	26 x 26	108
	Down		
30D, 28Z	Side	32 x 32	168
	Down	26 x 26	108
25	Side	32 x 32	168
	Down		
36D	Side	36 x 36	189
	Down	32 x 32	168

WARNING!!

Failure to properly size ductwork may cause system effect and reduce the performance of the equipment.

Figure 2 - Typical Roof Mount Installation

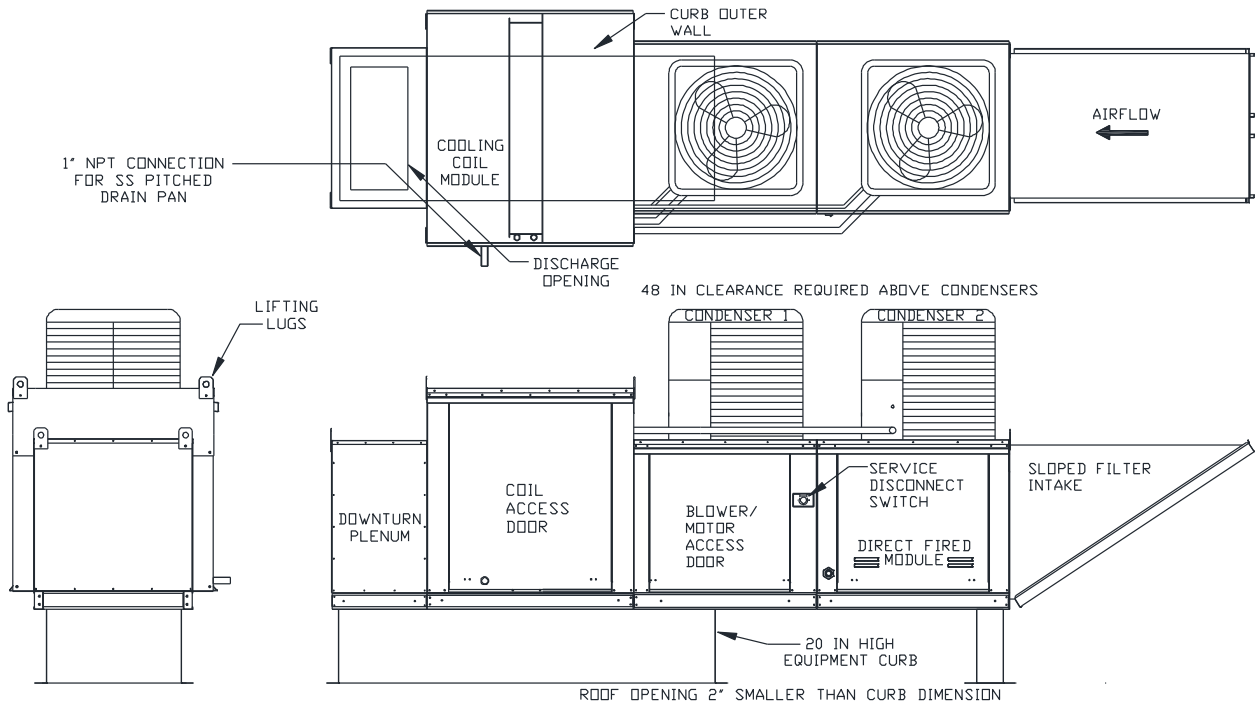
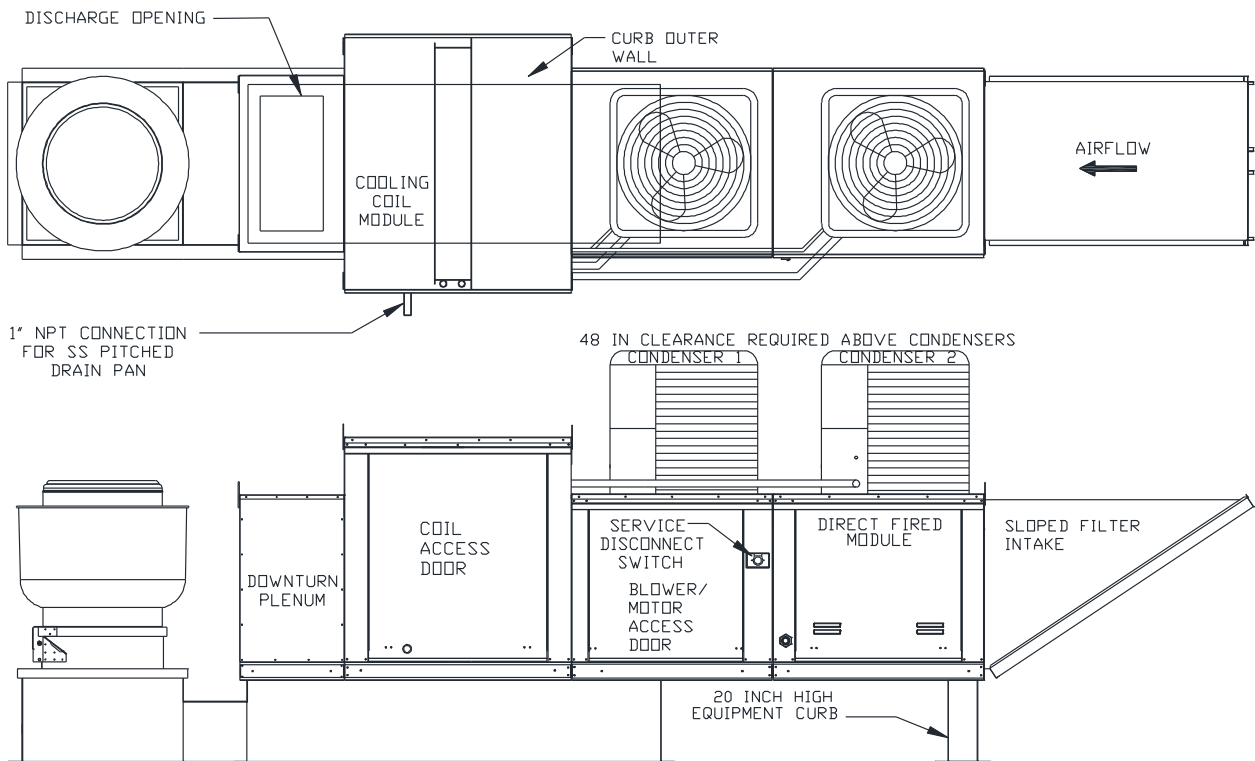

Figure 3 - Typical Roof Mount Installation with Exhaust Fan



Optional Moisture Eliminator Panel

If the unit is equipped with an optional moisture eliminator panel, the maximum face velocity of the coil may be increased to 650 FPM. Moisture eliminator panels require minimal maintenance. Visual inspection is recommended periodically. Scale or clogging will impair performance. If scale or clogging occurs, the moisture eliminator panel can be cleaned in place without removing it from the unit using steam or water. Flushing should not have sufficient force to dislodge the media from the panel. Scale removal may require a vinegar or detergent application followed by rinsing.

Overflow Switch

The overflow switch (**Figure 4**) is located in the cooling coil cabinet. This switch monitors the water level from condensation in the drain pan. When the overflow switch is tripped, cooling will shut down.

Figure 4 - Typical Overflow Switch

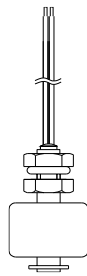

Plumbing Connections

There is one field plumbing connection required for proper DX coil operation. This is located at the drain pan located under the DX coil. Depending on the size of the unit, the coil can generate 5 gallons of water per hour. The plumbing must be sized accordingly. It is also recommended that all plumbing connections are sealed with Teflon tape or pipe dope.

Install Condensate Trap Assembly (**Figure 5**) to 1" threaded drain pan connection. Use low-profile couplings and 1" PVC piping to connect on-site drainage to the Condensate Trap Assembly. **DO NOT USE UNIONS.** The Condensate Trap Assembly is important for two reasons. First, it will allow drainage to be piped to the most convenient area. Second, it will keep air from being drawn into the system, impeding drainage. The top lids of the Condensate Trap Assembly should be removable to allow for cleaning of the trap.

Figure 5 - Typical Cooling Coil Drain Trap

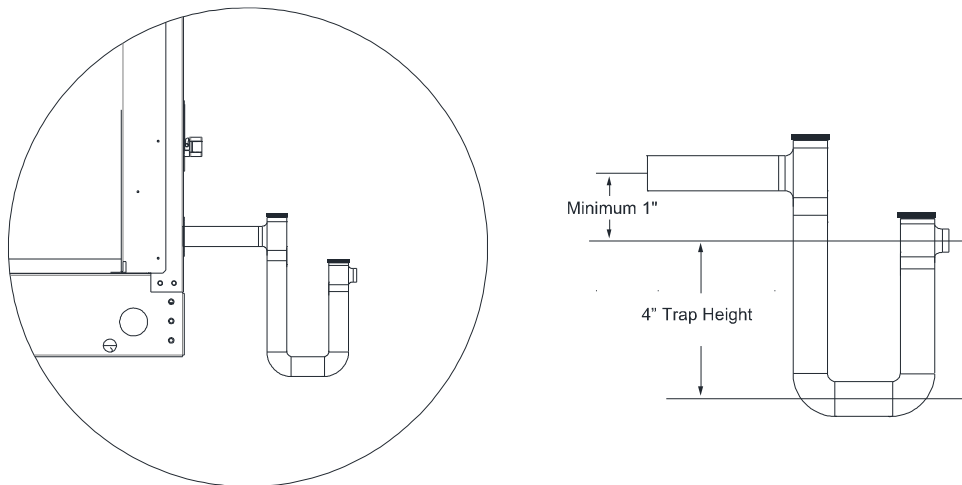

ELECTRICAL

WARNING!!

Disconnect power before installing or servicing fan. High voltage electrical input is needed for this equipment. This work should be performed by a qualified electrician.

Refer to the Make-up air (MUA) manual that shipped with this unit for gas installation details.

Before connecting power to this unit, read and understand the entire section of this document. As-built wiring diagrams are furnished with each fan by the factory and are attached to the door of the unit.

Electrical wiring (**Table 2**) and connections should be done in accordance with local ordinances and the National Electric Code, ANSI/NFPA70. Be sure the voltage and phase of the power supply and the wire amperage capacity is in accordance with the motor nameplate. For additional safety information refer to AMCA publication 410-96, *Recommended Safety Practices for Users and Installers of Industrial and Commercial Fans*.

1. Always **disconnect power** before working on or near this unit. Lock and tag the disconnect switch or breaker to prevent accidental power-up.
2. This unit contains 2 or 3 disconnect switches and multiple wiring connections. One disconnect is for the MUA blower. The second disconnect is used for units with 2 condensers. A third disconnect is added for units with 3 condensers. An electrical drop containing the motor power wiring and a separate drop containing condenser power is shipped with every fan. The electrical drops should be brought through one of the conduit openings located in the base of the unit, run through the curb and connected to a junction box inside the building.
3. A dedicated branch circuit should supply the motor circuit with short circuit protection according to the National Electric Code. This dedicated branch should be run to the junction box and connected as shown in **Figure 7**.
4. Make certain that the power source is compatible with the requirements of your equipment. The heater nameplate identifies the **proper phase and voltage** of the motor. 3 phase condensers have circuit boards that protect the compressor from running backwards. The board (located under the condenser wiring panel) will produce a fault light if the 3 phase input needs to be reversed to that condenser.
5. Units shipped with an optional remote panel have three electrical circuit drops (**Figure 6**). It is important to run the motor wires in a separate conduit from the remote control wiring. The DC wires from the unit temperature controller, located in the control drop, should either be shielded cable or be run in a separate conduit.
6. Before connecting unit to the building power source, verify power line wiring is de-energized.
7. Secure the power cables to prevent contact with sharp objects.
8. Do not kink power cable and never allow the cable to encounter oil, grease, hot surfaces, or chemicals.
9. Before powering up the heater, check fan wheel for free rotation and make sure that the interior of the heater is free of loose debris or shipping materials.
10. If any of the original wire supplied with the heater must be replaced, it must be replaced with type THHN wire or equivalent.

Table 2 - Copper Wire Ampacity

Wire Size AWG	Maximum Amps
14	15
12	20
10	30
8	50
6	65
4	85

Figure 6 – Wiring Drops

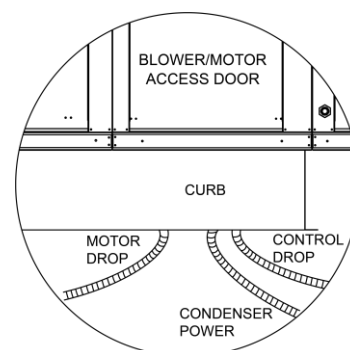

MUA/Condenser Fan to Building Wiring Connection

Figure 7 – Fan to Building Wiring

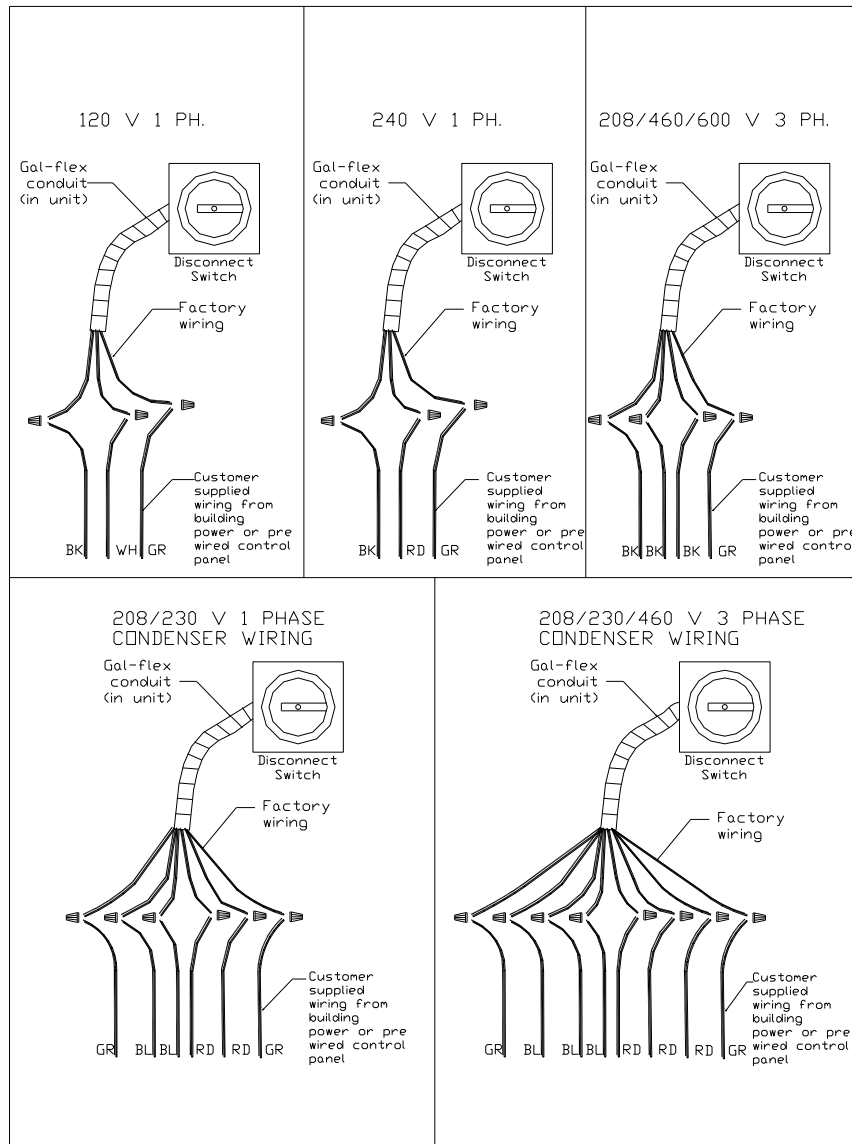

Single Phase Condenser: Condenser 1 is the Blue/Blue lines; Condenser 2 is the Red/Red lines; Condenser 3 is the Grey/Grey lines.

Three Phase Condenser: Condenser 1 is the Blue/Blue/Blue lines; Condenser 2 is the Red/Red/Red lines; Condenser 3 is the Grey/Grey/Grey lines.

Variable Frequency Drive (VFD) Installation Instructions

Input AC Power

1. Circuit breakers feeding the VFDs are recommended to be thermal-magnetic and fast-acting. They should be sized based on the VFD amperage and according to the table below. Refer to the installation schematic for exact breaker sizing.
2. Each VFD should be fed by its own breaker. If multiple VFDs are to be combined on the same breaker, each drive should have its own protection measure (fuses or miniature circuit breaker) downstream from the breaker.
3. Input AC line wires should be run in conduit from the breaker panel to the drives. AC input power to multiple VFDs can be run in a single conduit if needed. **Do not combine input and output power cables in the same conduit.**
4. The VFD should be grounded on the terminal marked PE. A separate insulated ground wire must be provided to each VFD from the electrical panel. This will reduce the noise being radiated in other equipment.

ATTENTION!

DO NOT CONNECT INCOMING AC POWER TO OUTPUT TERMINALS U, V, W. SEVERE DAMAGE TO THE DRIVE WILL RESULT. INPUT POWER MUST ALWAYS BE WIRED TO THE INPUT L TERMINAL CONNECTIONS (L1, L2, L3)

VFD Output Power

1. Motor wires from each VFD to its respective motor **MUST** be run in a **separate steel** conduit away from control wiring and incoming AC power wiring to avoid noise and crosstalk between drives. An insulated ground must be run from each VFD to its respective motor. Do not run different fan output power cables in the same conduit.
2. VFD mounted in ECP: If the distance between VFD and the motor is greater than the distances specified below, a load reactor should be used between VFD and motor. The load reactor should be sized accordingly and installed within 10 feet of the output of the VFD.
208/230V – Load reactor should be used when distance exceeds 250 feet.
460/480V – Load reactor should be used when distance exceeds 50 feet.
575/600V – Load reactor should be used when distance exceeds 25 feet.
3. VFD mounted in fan: The load reactor should be sized accordingly when VFD is mounted in the fan.
208/230V – Load reactor is optional but recommended for 15 HP and above motors.
460/480V – Load reactor is optional but recommended for 7.5 HP and above motors.
575V/600V – Load reactors are required for all HP motors.
4. If the distance between VFD and the motor is extremely long, up to 1000 FT, a dV/dT filter should be used. The VFD should be increased by 1 HP or to the next size VFD. The dV/dT filter should be sized accordingly and installed within 10 feet of the output of the VFD.
208/230V – dV/dT filter should be used when distance exceeds 400 feet.
460/480V – dV/dT filter should be used when distance exceeds 250 feet.
575/600V – dV/dT filter should be used when distance exceeds 150 feet.
5. No contactor should be installed between the drive and the motor. Operating such a device while the drive is running can potentially cause damage to the power components of the drive.
6. When a disconnect switch is installed between the drive and motor, the disconnect switch should only be operated when the drive is in a STOP state.

VFD Programming

Programming

1. The Drive should be programmed for the proper motor voltage. P107 is set to 0 (Low) if motor voltage is 120 VAC, 208 VAC or 400 VAC. P107 is set to 1 (High) if motor voltage is 230 VAC, 480 VAC or 575 VAC.
2. The Drive should be programmed for the proper motor overload value. P108 is calculated as $\text{Motor FLA} \times 100 / \text{Drive Output Rating}$ (**page 13**).

To enter the PROGRAM mode to access the parameters:

1. Press the Mode (M) button. This will activate the password prompt (PASS).
2. Use the Up and Down buttons to scroll to the password value (the factory default password is "0225") and press the Mode (M) button. Once the correct password is entered, the display will read "P100", which indicates that the PROGRAM mode has been accessed at the beginning of the parameter menu.
3. Use the Up and Down buttons to scroll to the desired parameter number.
4. Once the desired parameter is found, press the Mode (M) button to display the present parameter setting. The parameter value will begin blinking, indicating that the present parameter setting is being displayed. The value of the parameter can be changed by using the Up and Down buttons.
5. Pressing the Mode (M) button will store the new setting and also exit the PROGRAM mode. To change another parameter, press the Mode (M) button again to re-enter the PROGRAM mode. If the Mode button is pressed within 1 minute of exiting the PROGRAM mode, the password is not required to access the parameters. After one minute, the password must be re-entered to access the parameters again.

P500 parameter provides a history of the last 8 faults on the drive. It can be accessed without getting into PROGRAM mode.

ACTECH SMV VFD CROSS-REFERENCE TABLE

HP	Part Number	Volts	1Ø Input	3Ø Input	Input Amps 1Ø 120VAC	Input Amps 1Ø 240VAC	Output Amps	Breaker 1Ø 120VAC	Breaker 1Ø 240VAC
0.33	ESV251N01SXB571	120/240V	X		6.8	3.4	1.7	15	15
0.5	ESV371N01SXB571	120/240V	X		9.2	4.6	2.4	15	15
1	ESV751N01SXB571	120/240V	X		16.6	8.3	4.2	25	15
1.5	ESV112N01SXB571	120/240V	X		20	10	6	30	20

HP	Part Number	Volts	1Ø Input	3Ø Input	Input Amps 1Ø	Input Amps 3Ø	Output Amps	Breaker 1Ø	Breaker 3Ø
0.5	ESV371N02YXB571	240V	X	X	5.1	2.9	2.4	15	15
1	ESV751N02YXB571	240V	X	X	8.8	5	4.2	15	15
1.5	ESV112N02YXB571	240V	X	X	12	6.9	6	20	15
2	ESV152N02YXB571	240V	X	X	13.3	8.1	7	25	15
3	ESV222N02YXB571	240V	X	X	17.1	10.8	9.6	30	20
5	ESV402N02TXB571	240V		X		18.6	16.5		30
7.5	ESV552N02TXB571	240V		X		26	23		40
10	ESV752N02TXB571	240V		X		33	29		50
15	ESV113N02TXB571	240V		X		48	42		80
20	ESV153N02TXB571	240V		X		59	54		90

1	ESV751N04TXB571	480V		X		2.5	2.1		15
1.5	ESV112N04TXB571	480V		X		3.6	3		15
2	ESV152N04TXB571	480V		X		4.1	3.5		15
3	ESV222N04TXB571	480V		X		5.4	4.8		15
5	ESV402N04TXB571	480V		X		9.3	8.2		15
7.5	ESV552N04TXB571	480V		X		12.4	11		20
10	ESV752N04TXB571	480V		X		15.8	14		25
15	ESV113N04TXB571	480V		X		24	21		40
20	ESV153N04TXB571	480V		X		31	27		50
25	ESV183N04TXB571	480V		X		38	34		70
30	ESV223N04TXB571	480V		X		45	40		80

1	ESV751N06TXB571	600V		X		2	1.7		15
2	ESV152N06TXB571	600V		X		3.2	2.7		15
3	ESV222N06TXB571	600V		X		4.4	3.9		15
5	ESV402N06TXB571	600V		X		6.8	6.1		15
7.5	ESV552N06TXB571	600V		X		10.2	9		20
10	ESV752N06TXB571	600V		X		12.4	11		20
15	ESV113N06TXB571	600V		X		19.7	17		30
20	ESV153N06TXB571	600V		X		25	22		40
25	ESV183N06TXB571	600V		X		31	27		50
30	ESV223N06TXB571	600V		X		36	32		60
40	ESV303N06TXB571	600V		X		47	41		70
50	ESV373N06TXB571	600V		X		59	52		90
60	ESV453N06TXB571	600V		X		71	62		110

OPERATION

Prior to starting up or operating this unit, check all fasteners for tightness. In particular, check the set screw in the wheel hub, bearings and the fan sheaves (pulleys). With power and/or gas OFF or prior to connecting ventilator to power, turn the fan wheel by hand to be sure it is not striking the inlet or any obstacles. Re-center if necessary.

WARNING: GLOVES AND SAFETY GLASSES MUST BE WORN WHEN SERVICING REFRIGERATION EQUIPMENT.

Special Tools Required

- AC Voltage Meter
- Tachometer
- Standard Hand Tools
- Refrigeration Gauge Set
- Amperage Meter
- Manometer
- Differential Pressure Gauge
- Thermometer

Start-up Procedure

1. Check all electrical connections for tightness and continuity.
2. Check pulley alignment and belt tension.
3. Inspect the condition of the intake damper and damper linkage, if provided.
4. Inspect the air-stream for obstructions and install intake filters if missing.
5. Compare the supplied **motor voltage** with the fan's nameplate motor voltage. If this does not match, correct the problem.
6. Start the fan up, by turning the external MUA disconnect to the **ON** position, and shut it **OFF** immediately to **check rotation of the wheel** with the directional arrow on the blower scroll. Reversed rotation will result in poor air performance, motor overloading and possible burnout. For units equipped with a single-phase motor, check the motor wiring diagram to change rotation. For 3-phase motors, any two power leads can be interchanged to reverse motor direction.
7. When the fan is started up, observe the operation and check for any unusual noises.
8. Once the fan is operating properly, turn the condenser disconnect to the **ON** position. If the outside air temperature is below 55°F, the condensers should not operate for an extended period.
9. Connect a refrigerant gauge set as shown below to the right.
10. Turn the cooling thermostat down to energize the first condenser.
11. Let the condenser operate for about 15 minutes and check refrigerant operating temperature and pressure. For R410-A refrigerant, the proper suction temperature is approximately 45°F and the proper liquid temperature is approximately 100°F.
12. Set the refrigerant level to the proper subcooling range, refer to **Table 3**. Also, adjust the TXV to 10 degrees of superheat.
13. Disconnect the gauge set and repeat these steps on the other condensers if needed. The cooling thermostat will need to be turned down further to energize the second or third condenser.
14. If the unit is a cooling only unit, adjust the air proving switch such that prevailing winds cannot start the condensers without the blower operating. With the unit operating, turn the adjustment screw (right side) clockwise until condensers stop operating. Then turn the adjustment screw counterclockwise until condensers operate. Turn the screw two more full turns counterclockwise.
15. Refer to the MUA manual to complete the startup of the MUA unit.

Checking the Refrigerant Charge

Subcooling is used to identify an over or under-charged system. Typical systems will run between 10°F and 20°F of subcooling. If lower than 10°F, the system is likely undercharged. If over 20°F, the system is probably overcharged. These "rules of thumb" are approximate. For the condensers used on this system, the appropriate subcooling target and range are displayed in **Table 3** (The first number in unit size is tonnage x 12).

Table 3 – Subcool Charge (TXV-Type Expansion Device)

Unit Size – Voltage & Series	Target Subcool	Allowable Subcool Range
18-31	10°F/5.6°C	10°F-20°F/5.6°C-11°C
24-31	10°F/5.6°C	
30-31, 51	10°F/5.6°C	
36-31, 51, 62, 12	14°F/7.8°C	
42-30, 50, 60	10°F/5.6°C	
48-31, 51, 62, 12	15°F/8.3°C	
60-32	13°F/7.2°C	
60-52, 62, 12	10°F/5.6°C	

Subcooling is desirable because it increases the efficiency of an air conditioning system. However, too much subcooling will back liquid up in the condenser causing increased head pressures. This will cause the system to operate inefficiently and in extreme cases may cause the compressor to trip on its high pressure control or its internal protector.

Figure 8 shows a standard gauge set and liquid line reading for a system operating on R410A refrigerant.

Figure 8 – Gauge Connection/Readings Liquid Line



The liquid line saturation temperature is reading approximately 98°F from the gauge. The surface temperature of the liquid line is reading 83.5°F. The surface temperature reflects the actual temperature of the refrigerant. To calculate subcooling, subtract the surface temperature from the gauge temperature: **98°F – 83.5°F = 14.5°F of subcooling**

Compare the reading to the condenser nameplate subcooling. As a reminder, to increase subcooling, add refrigerant charge. To decrease subcooling, remove refrigerant charge.

R410A can be added to a system the same as previous R22 systems, such that it can be added as a liquid into the suction side if done slowly to allow the refrigerant to evaporate before entering the compressor.

Superheat and Adjusting TXVs

Ideally, the best way to check the operation of the TXV is to measure the superheat at the evaporator outlet. In many cases, this is not convenient for the technician, since there may be no gauge ports available. A superheat check at the condensing unit can be used instead. Since suction line lengths can vary, so can the superheat that is measured at the condensing unit. With short line lengths (less than 30 ft.), the superheat should be between 10°F and 15°F. With longer suction line lengths (between 30 and 50 ft.) superheats of 15°F to 20°F are normal.

Figure 9 shows a standard gauge set and suction line reading for a system operating on R410A refrigerant.

Figure 9 - Gauge Connection/Readings Suction Line



The suction line saturation temperature is reading approximately 44°F from the gauge. The surface temperature of the suction line is reading 54.1°F. The surface temperature reflects the actual temperature of the refrigerant. To calculate superheat, subtract the gauge temperature from the surface temperature: $54.1^{\circ}\text{F} - 44^{\circ}\text{F} = 10.1^{\circ}\text{F}$ of superheat.

This should be compared to the unit recommendation, which in this case is 10°F.

If the superheat is too low, and an adjustable-type valve is supplied, the superheat can be increased by turning the adjustment stem in a clockwise direction. It's a good practice to wait for 15 to 20 minutes after adjusting the valve, to allow for the system to balance out before determining the effect of the adjustment. If the superheat is too high, it can be lowered by turning the stem in a counter-clockwise direction.

To adjust the superheat, first remove the bottom cap from the TXV (**Figure 10**). Next, turn the adjustment screw clockwise to increase superheat or counterclockwise to decrease superheat. Adjust about ½ turn at a time and allow system to stabilize. Once proper superheat is set, replace the TXV cap.

Figure 10 – TXV Adjustment



Checking Heating Mode for Units with Heat Pumps

Refrigerant charge in heat pumps should be checked while the unit is in cooling mode with the same Subcooling and Superheat method described above. However, it is also important to check heating mode to make sure the unit is operating properly.

Attach the refrigerant gauges to the heat pump with the red high pressure line connected to the suction line and the blue low pressure line connected to the middle access port as shown below.

Turn the heating thermostat up until the first heat pump comes on. Allow the heat pump to run for 15 minutes and check the high side pressure. The pressure should not exceed the maximum operating pressure listed on the unit nameplate. If the pressure is high, refrigerant will need to be removed. Removing refrigerant will also affect cooling mode subcool and superheat, so they will need to be checked again also.

Sequence of Operation-Cooling with Direct, Indirect, or Electric Heat

This unit is most easily understood when broken down into smaller individual systems. There are two main systems, a make-up air (MUA) fan and a cooling system. The make-up air fan consists of a blower and motor. The cooling system consists of a condenser(s), DX coil, filter/dryer, and thermal expansion valve.

Basic cooling units include 2 thermostats for proper operation. The first thermostat is an intake air thermostat that prevents heating and cooling from occurring simultaneously. This is typically labeled "Burner ON/Off Intake Air Thermostat." This thermostat will allow the burner to operate when the outside air temperature falls below the setpoint and prevents the burner from operating when the outside air temperature rises above the set point. It also allows the cooling circuit to receive power when the outside air temperature rises above the set point. This thermostat is typically set at 45° F and is adjustable.

The second thermostat is a cooling thermostat. The cooling thermostat allows the cooling circuit to energize when the outside air rises above the set point. This is a 2 stage, differential thermostat; one set point that energizes where the thermostat is set and a second stage that energizes at a factory setting of 10°F higher. The main setpoint controls the first stage of cooling and the differential controls the second stage of cooling. This thermostat is factory set at 85°F; the factory setting and subsequent differential setting are both adjustable.

- With the blower already running and the airflow switch proven;
 - ✓ The air temperature rises above the setting of intake air thermostat and the cooling thermostat
- OR
- ✓ The optional remote panel is set to "Manual" and "Cool" mode, and the temperature rises above both thermostats as mentioned above.
- The first stage condenser energizes and cooling starts.
- The air temperature continues to rise above the cooling thermostat differential and the second stage of cooling (if equipped) is energized.
- Once the air temperature falls below the differential, the second stage of cooling is de-energized.
- Once the air temperature falls below the cooling thermostat set point, both stages of cooling are de-energized.

*****AN OPTIONAL PROGRAMMABLE THERMOSTAT IS AVAILABLE. WHEN THIS IS PROVIDED, AS-BUILT SCHEMATICS AND A SEPARATE MANUAL IS PROVIDED FOR THE THERMOSTAT*****

Sequence of Operation-Reheat

The unit can be equipped with an optional reheat coil downstream from the DX coil. When this option is installed, warm, liquid refrigerant will flow through a reheat coil before it enters the DX coil. This warms the cooled air discharged from the DX coil and helps to lower the relative humidity of the airstream. Reheat is always activated in this system and only uses refrigerant from stage 1.

Sequence of Operation-Liquid Bypass

This system can be installed with a Liquid Bypass option. This option helps prevent coil freezing by injecting warm liquid refrigerant directly into the DX coil, bypassing the TXV. The system is controlled by a Bypass Thermostat whose sensing bulb is strapped to the vertical portion of the stage 1 suction line. When the Bypass Thermostat reads a temperature below 35° F, it sends a signal to a 24V solenoid valve. The valve opens and allows warm liquid refrigerant to bypass the TXV and go directly into the DX coil. Once the thermostat reads a temperature above 35° F in the suction line, it shuts off the solenoid valve and the system will continue to operate normally.

Sequence of Operation-Cooling Only or Heat Pump

Onboard HMI

- MENU – Used to return back one screen each time it is pressed. If any value has been altered and the menu button is pressed, that value will save.
- UP – Used to navigate up through the current list of items.
- DOWN – Used to navigate down through the current list of items
- ENTER – Used to advance once screen each time it is pressed. If any value has been altered and the enter button is pressed, that value will save.

(If any value has been changed, the board will automatically reboot when the user exits to the home screen)

Info

- Temperature – Contains values for Discharge, Return, Outside Intake, Space, Mixed Air, Outdoor-Discharge ΔT , and Return-Discharge ΔT . Will show disconnected if there is no sensor present.
- Date/Time – Displays time and date based on real-time clock (RTC).
- Outputs – Output voltage to RTU out 0-10V #1.
- Timers – Displays uptime of the board.
- Mixed Air Info – Displays live outdoor air % and return air %.

Configuration

- Modbus Address – This address which will be used to communicate with the board.
- # Of Stages – Configurable to 1, 2, or 3 stages.
- Control Mode – Auto (heat/cool), heat, cool, off.
- Staged Based On – Outside, space.
- Activate Based On – Outside, space, both, either.
- Space Cool SP – Stage 1 space cooling set point.
- Space Cool SP #2 – Stage 2 space cooling set point.
- Space Cool SP #3 – Stage 3 space cooling set point.
- Space Heat SP – Stage 1 space heating set point.
- Space Heat SP #2 – Stage 2 space heating set point.
- Space Heat SP #3 – Stage 3 space heating set point.
- Outdoor Cool SP – Stage 1 outdoor cooling set point.
- Outdoor Cool SP #2 – Stage 2 outdoor cooling set point.
- Outdoor Cool SP #3 – Stage 3 outdoor cooling set point.
- Outdoor Heat SP – Stage 1 outdoor heating set point.
- Outdoor Heat SP #2 – Stage 2 outdoor heating set point.
- Outdoor Heat SP #3 – Stage 3 outdoor heating set point.

(All tempering set points may not be available depending on the selected # of stages and staging/activation selections)

- Min. Outdoor Air Temp – This value is in place to ensure that a unit is not trying to cool when the ambient outside temperature is too low. This will help prevent coils from freezing. It is factory set at 60° F and adjustable between 55-65° F.
- O/B Output Mode – This option allows you to choose whether the output energizes during cooling or heating. This output is driven by what company heat pump is being utilized. Carrier's standard is to energize with cooling.
- Mode Change Time – This time dictates how long the unit must wait before switching from heating to cooling or vice versa. Factory set at 5 minutes. Adjustable between 1-10 minutes.
- Heat Hysteresis – Factory set a 1° F, adjustable between 1-5° F.
- Cool Hysteresis – Factory set a 1° F, adjustable between 1-5° F.
- Min. Heat On Time – Time any heating stage must stay on after being activated. Factory set at 2 minutes. Adjustable between 1-5 minutes.
- Min. Cool On Time – Time any cooling stage must stay on after being activated. Factory set at 2 minutes. Adjustable between 1-5 minutes.
- Min. Heat Off Time – Time any heating stage must stay off after being de-activated. Factory set at 2 minutes. Adjustable between 1-5 minutes.
- Min. Cool Off Time – Time any cooling stage must stay off after being de-activated. Factory set at 2 minutes. Adjustable between 1-5 minutes.

- Mixing Box Type – Selectable between none, external, and adjustable. Choosing external or adjustable both enables the use of return and mixed air sensors. When adjustable is chosen it also enables the 0-10V damper position output on the board.
- Damper Position – This is a user selectable 0-100 percent, and once set, the board will try to maintain that percentage of outdoor air by altering its output voltage to the damper.
- MB Deadband – This relates to the absolute value of the delta T between outdoor air and return air. If the delta T falls within the deadband range, the board will not alter its output voltage to the damper. The voltage will be a constant 0-10V directly related to the 0-100 damper position. Factory set at 5° F and adjustable between 1-10° F.
- Return As Space – This option is enabled when a mixing box is selected. If an adequate space sensor can't be mounted within the space, the board has the ability to treat the return air sensor as the space sensor.
- Startup Time – Delay upon powering up until the board allows any pins to be active. Factory set at 5 seconds.
- Reboot – Reboots the board.
- Factory Reset – Resets the board to the last commissioned settings.

Faults

- View Faults – This menu will store faults even once the board has lost power. Possible faults include airflow, alarm 1 (float switch), heating discharge, and cooling discharge. Heating and cooling discharge faults occur when there has been no ΔT for 30 minutes.
- Clear Faults – Once the faults have been resolved, choosing this option will wipe them from the board's memory. If the fault has not been resolved, it could re-appear on the view faults screen.

Diagnostics

- RTU Y1 – Option to enable or disable Y1 (stage 1) output.
- RTU Y2 – Option to enable or disable Y2 (stage 2) output.
- RTU Y3 – Option to enable or disable Y3 (stage 3) output.
- RTU O/B – Option to enable or disable O/B output.
- RTU 10V Out 1 – 0-10V adjustable output
- Exit – In order to back out of diagnostics mode, this menu item must be selected.

Board Menu

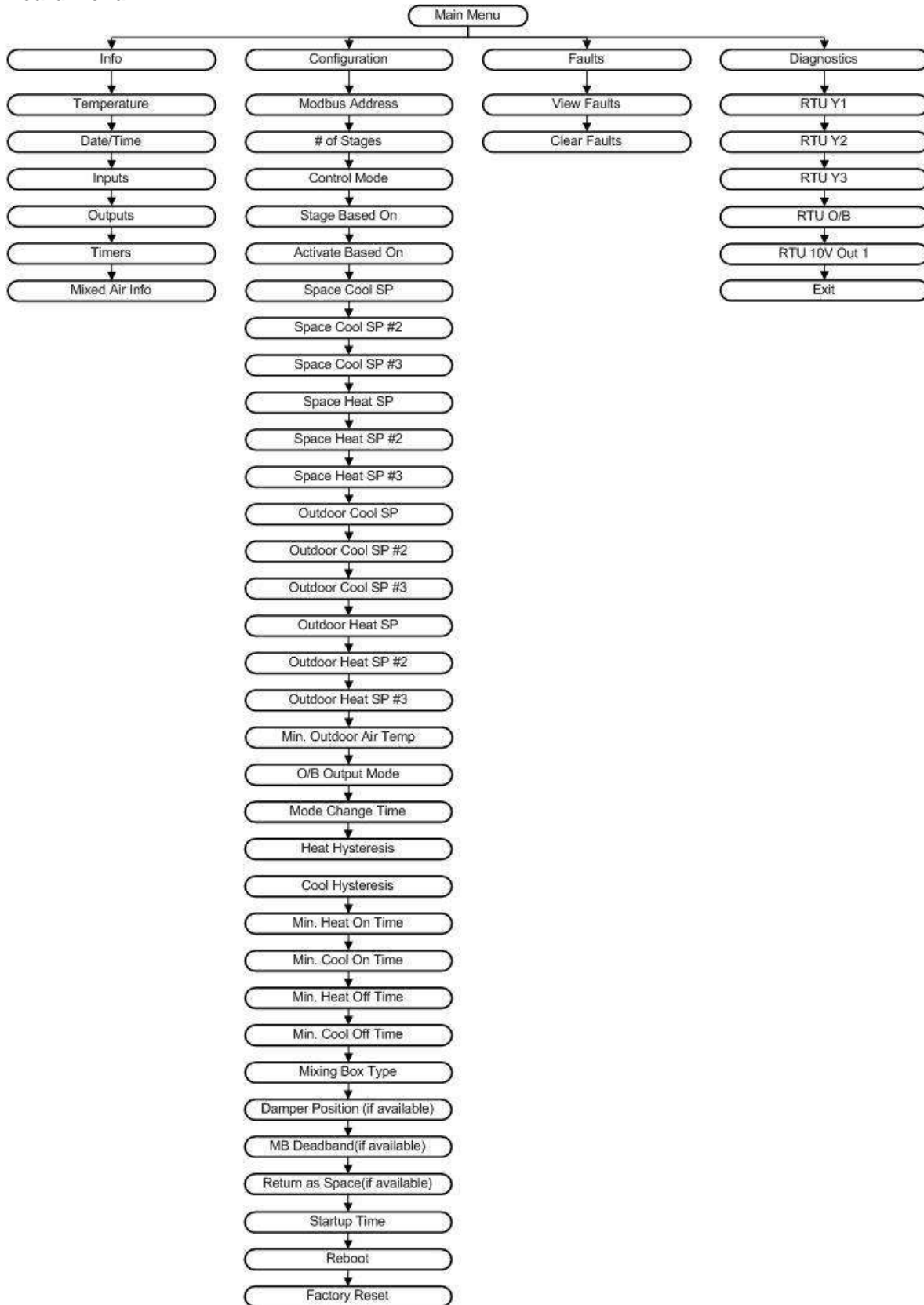

Components

Figure 11 outlines the typical modular packaged unit components. Systems are available with heating modules, mixing boxes and 1, 2 or 3 condensers.

Figure 11 – Typical Components

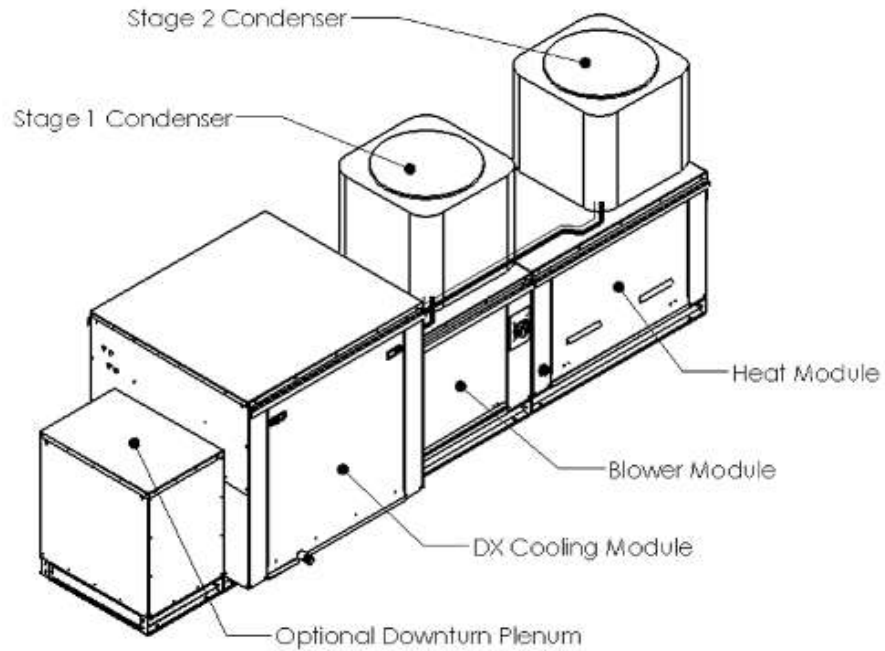

Thermal Expansion Valves



Filter/Dryer

Troubleshooting

The following tables list causes and corrective actions for possible problems with the units. Review these lists before consulting manufacturer.

Troubleshooting Chart

Problem	Potential Cause	Corrective Action
Fan Inoperative	<ul style="list-style-type: none"> Blown fuse Open circuit breaker 	<ul style="list-style-type: none"> Check amperage Check fuse, replace if needed Check circuit breaker
	Disconnect switch in "Off" position	Turn to "On" position
	Motor wired incorrectly	Check motor wiring. Verify connections with wiring diagram located on fan motor
	Broken fan belt	Replace belt
	Motor starter overloaded	<ul style="list-style-type: none"> Check amperage Reset starter
	Remote panel set to "Off" Position	Set Remote Panel to "Manual" or "Auto" Position
Motor Overload	Fan rotating in the wrong direction	Verify the fan is rotating in the direction shown on rotation label
	Fan speed is too high	Reduce fan RPM
	Motor wired incorrectly	Check motor wiring. Verify connections with wiring diagram located on fan motor
	Overload in starter set too low	Set overload to motor FLA value
	Motor HP too low	Determine if HP is sufficient for job
	Duct static pressure lower than design	Reduce fan RPM
Insufficient Airflow	Fan rotating in the wrong direction	Verify the fan is rotating in the direction shown on rotation label
	Poor outlet conditions	There should be a straight clear duct at the outlet
	Intake damper not fully open	Inspect damper linkage. If the linkage is damaged, replace damper motor
	Duct static pressure higher than design	Check ductwork. Adjust/resize to eliminate or reduce duct losses
	Blower speed too low	Increase fan RPM. Do not overload motor
	Supply grills or registers closed	Open and adjust
	Dirty/clogged filters	Clean filters. Replace filters if they cannot be cleaned or are damaged
	Belt slippage	Adjust belt tension
Excessive Airflow	Blower speed too high	Reduce fan RPM
	Filters not installed	Install filters
	Duct static pressure lower than design	Reduce fan RPM
Excessive Vibration and Noise	Misaligned pulleys	Align pulleys
	Damaged/unbalanced wheel	Replace wheel
	Fan is operating in the unstable region of the fan curve	Refer to performance curve for fan
	<ul style="list-style-type: none"> Bearings need lubrication Damaged bearing 	<ul style="list-style-type: none"> Lubricate bearings Replace bearings if damaged
	Fan speed is too high	Reduce fan RPM
	<ul style="list-style-type: none"> Dirty/oily belt Belts too loose Worn belt 	<ul style="list-style-type: none"> Clean belts Inspect and replace if needed
No Cooling	Condenser Disconnect is Off	Turn Disconnect to ON Position
	Outside Air Temp is cooler than thermostat setting	Turn thermostat to desired cooling activation set point. Do not turn below 55° F.
	Frozen Coil	Ensure airflow through unit is correct and refrigeration charge is correct. Low airflow will cause the coil to freeze.
Insufficient Cooling	Refrigerant Leak	Ensure refrigerant has not leaked out of unit.
	Excessive Airflow	Reduce the airflow volume
	Incorrect Refrigerant Charge	Refrigerant charge must be checked by a refrigeration contractor

MAINTENANCE

To guarantee trouble-free operation of this unit, the manufacturer suggests following these guidelines. Most problems associated with fan failures are directly related to poor service and maintenance.

Please record any maintenance or service performed on this fan in the documentation section located at the end of this manual.

WARNING: DO NOT ATTEMPT MAINTENANCE ON THE UNIT UNTIL THE ELECTRICAL SUPPLY HAS BEEN COMPLETELY DISCONNECTED AND THE MAIN GAS SUPPLY VALVE (IF REQUIRED) HAS BEEN TURNED OFF.

General Maintenance

1. Fan inlet and approaches to ventilator should be kept clean and free from any obstruction.
2. Motors are normally permanently lubricated. Check bearings periodically. If they have grease fittings, lubricate each season. Use caution when lubricating bearings - wipe the fittings clean and the unit should be rotated by hand while lubricating. **Caution: Use care when touching the exterior of an operating motor. Motors normally run hot and may be hot enough to be painful or cause injury.**
3. All fasteners should be checked for tightness each time maintenance checks are performed before restarting unit.
4. Blowers require very little attention when moving clean air. Occasionally, oil and dust may accumulate causing imbalance. If the fan is installed in a corrosive or dirty atmosphere, periodically inspect and clean the wheel, inlet and other moving parts to ensure smooth and safe operation.
5. Do not block or cover airflow to condensing units. Do not allow grass clippings, leaves or other debris to accumulate on the sides or top of the unit.
6. Do not operate the air conditioning system when the outdoor air is less than 55° F.

2 weeks after startup

1. Belt tension should be checked after the first 2 weeks of fan operation. Belts tend to stretch and settle into pulleys after an initial start-up sequence. **Do not tension belts by changing the setting of the motor pulley**, this will change the fan speed and may damage the motor. To re-tension belts, turn the power to the fan motor OFF. Loosen the fasteners that hold the blower scroll plate to the blower. Rotate the motor to the left or right to adjust the belt tension. Belt tension should be adjusted to allow 1/64" of deflection per inch of belt span. Exercise extreme care when adjusting V-belts, as not to misalign pulleys. Any misalignment will cause a sharp reduction in belt life and produce squeaky noises. Over-tightening will cause excessive belt and bearing wear, as well as noise. Too little tension will cause slippage at startup and uneven wear. **Whenever belts are removed or installed, never force belts over pulleys without loosening motor first to relieve belt tension.** When replacing belts, use the same type as supplied by the manufacturer. On units shipped with double groove pulleys, matched belts should always be used.
2. All fasteners should be checked for tightness each time maintenance checks are performed before restarting unit.

Every 3 months

1. Belt tension should be checked quarterly. See instructions in the previous maintenance section. Over-tightening will cause excessive bearing wear and noise. Too little tension will cause slippage at startup and uneven wear.
2. Filters need to be cleaned and/or replaced quarterly, and more often in severe conditions. Washable filters can be washed in warm soapy water. When re-installing filters, be sure to install with the **airflow in the correct direction** as indicated on the filter.
3. Check for and remove debris that has settled around the base of the condenser. This will ensure proper water drainage from the condenser.

Yearly

1. Inspect bearings for wear and deterioration. Replace if necessary.
2. Inspect belt wear and replace torn or worn belts.
3. Inspect bolts and set screws for tightness. Tighten as necessary.
4. Inspect motor for cleanliness. Clean exterior surfaces only. Remove dust and grease from the motor housing to ensure proper motor cooling. Remove dirt and grease from the wheel and housing to prevent imbalance and damage.

Coil Cleaning Procedure

Do not use a pressure washer or high-water pressure when cleaning the coil.

Always use water to rinse the coil down before using third party cleaning solutions. The use of cleaning solutions and chemicals should be used cautiously, overuse will cause damage to the equipment. If the coil cannot be cleaned with water only, follow the below procedure to clean the coil.

Caution: Do not use coil cleaning solution without diluting per cleaning solution manufacturer's dilution ratios and directions. Use a non-acidic, low/mild alkaline cleaner specified for washing and cleaning aluminum/copper coils. Coil cleaners can be aggressive products. If not diluted properly and rinsed thoroughly, damage to equipment will occur.

Note: Always wear eye protection, gloves, and other protective clothing when using cleaning solutions. Avoid breathing solution and mist.

1. Shut the system OFF. Spray the coil surface with only water before applying the cleaning solution.
2. Apply the diluted cleaning solution to the coil.
3. Allow the cleaning solution to saturate the coil for no more than 5 minutes.
4. Thoroughly rinse the cleaning solution from the coil with only water. Verify the coil is clean, and no foam deposits are present. Repeat steps 1-4 if the coil is not sufficiently clean.
5. Once the coil is clean, return the system back to service.
6. Always clean the following items thoroughly with water once the system is back to service: tools, sprayer, roof, nearby areas and equipment that may have come in contact with cleaning solution, etc.

When cleaning coils, specifically where considerable foaming solution deposits are present, it is essential to rinse the coil, equipment, and surrounding areas thoroughly. Many coil cleaners can be aggressive products, and residual left behind can be corrosive and damage equipment.

Extensively rinse coils from the bottom of the equipment and all other surrounding metal surfaces. Never allow the foam to rest or soak in an area, whether on a roof surface, surrounding areas or nearby equipment.

Start-Up and Maintenance Documentation

START-UP AND MEASUREMENTS SHOULD BE PERFORMED AFTER THE SYSTEM HAS BEEN AIR BALANCED AND WITH THE COOLING ON (Warranty will be void without completion of this form).

Job Information

Job Name	
Address	
City	
State	
Zip	
Phone Number	
Fax Number	
Contact	
Purchase Date	

Service Company	
Address	
City	
State	
Zip	
Phone Number	
Fax Number	
Contact	
Start-Up Date	

Unit Information

Refer to the start-up procedure in this manual to complete this section.

Name Plate and Unit Information	
Model Number	
MUA Serial Number	
Motor Volts	
Motor Hertz	
Motor Phase	
Motor FLA	
Motor HP	
Blower Pulley	
Motor Pulley	
Belt Number	
Gas Type	
Min. Btu/Hr	
Max. Btu/Hr	
COND 1 Serial Number	
COND 2 Serial Number	
COND 3 Serial Number	

Field Measured Information	
Motor Voltage	
Motor Amperage**	
MUA Blower RPM	
Ambient Wet Bulb Temp	°F
Ambient Dry Bulb Temp	°F
COND 1 Suction Pressure	PSI
COND 1 Suction Temperature	°F
COND 1 Liquid Pressure	PSI
COND 1 Liquid Temperature	°F
COND 1 Subcooling	°F
COND 1 Superheat	°F
COND 2 Suction Pressure	PSI
COND 2 Suction Temperature	°F
COND 2 Liquid Pressure	PSI
COND 2 Liquid Temperature	°F
COND 2 Subcooling	°F
COND 2 Superheat	°F
COND 3 Suction Pressure	PSI
COND 3 Suction Temperature	°F
COND 3 Liquid Pressure	PSI
COND 3 Liquid Temperature	°F
COND 3 Subcooling	°F
COND 3 Superheat	°F
Cooling Thermostat Set-Point	°F
Airflow Direction	Correct
	Incorrect

**If measured amps exceed the FLA rating on the nameplate, fan RPM must be reduced to decrease the measured amps below the nameplate FLA rating.

